



# Biology

Student Textbook  
Grade 11

Author: Steve Potter

Adviser: Alemu Asfaw

Evaluators: Solomon Belayneh  
Getachew Bogale  
Silas Araya



**Federal Democratic Republic of Ethiopia**  
**Ministry of Education**



## Acknowledgments

The development, printing and distribution of this student textbook has been funded through the General Education Quality Improvement Project (GEQIP), which aims to improve the quality of education for Grades 1–12 students in government schools throughout Ethiopia.

The Federal Democratic Republic of Ethiopia received funding for GEQIP through credit/financing from the International Development Associations (IDA), the Fast Track Initiative Catalytic Fund (FTI CF) and other development partners – Finland, Italian Development Cooperation, the Netherlands and UK aid from the Department for International Development (DFID). MOE/GEQIP/IDA/ICB/001/09

The Ministry of Education wishes to thank the many individuals, groups and other bodies involved – directly and indirectly – in publishing the textbook and accompanying teacher guide.

The publisher would like to thank the following for their kind permission to reproduce their photographs:

(Key: b-bottom; c-centre; l-left; r-right; t-top)

**Alamy Images:** 3cr, 5cr, 18cl, 18br, 19tl, 19bl, 20bl, 22tl, 22tc/1, 22tr, 22cl, 22br, 46br, 84cl, 84bl, 89tr, 113c, 113cr, 184cr;

**Corbis:** 17cr, 17br, 22cr; **Getty Images:** 31c; Science Photo Library Ltd: 3br, 17c, 17cl, 18tl, 18cr, 19tr, 22tc, 28br, 39bl, 45cr, 48cl, 48cr, 49cl, 49cr, 52bl, 84tl, 112c, 112cl, 112cr, 112br, 113tc, 113tr, 134cl, 138tl, 138cl, 138bc, 139tl, 139cr, 139br, 140bl, 159br, 166cr, 171bl, 179br, 184cl, Laguna Design 3tr; **tbc:** 17bl

Cover images: Front: **Corbis:** cr; **Science Photo Library Ltd:** cl, c

All other images © Pearson Education

Every effort has been made to trace the copyright holders and we apologise in advance for any unintentional omissions. We would be pleased to insert the appropriate acknowledgement in any subsequent edition of this publication.

© Federal Democratic Republic of Ethiopia, Ministry of Education

First edition, 2002 (E.C.)

ISBN: 978-99944-2-012-4

Developed, Printed and distributed for the Federal Democratic Republic of Ethiopia, Ministry of Education by:

Pearson Education Limited

Edinburgh Gate

Harlow

Essex CM20 2JE

England

In collaboration with

Shama Books

P.O. Box 15

Addis Ababa

Ethiopia

All rights reserved; no part of this publication may be reproduced, stored in a retrieval system, or transmitted in any form or by any means, electronic, mechanical, photocopying, recording, or otherwise without the prior written permission of the copyright owner or a licence permitting restricted copying in Ethiopia by the Federal Democratic Republic of Ethiopia, Federal Negarit Gazeta, *Proclamation No. 410/2004 Copyright and Neighboring Rights Protection Proclamation, 10th year, No. 55, Addis Ababa, 19 July 2004.*

Disclaimer

Every effort has been made to trace the copyright owners of material used in this document. We apologise in advance for any unintentional omissions. We would be pleased to insert the appropriate acknowledgement in any future edition

Printed in Malaysia

# Contents

---

<b>Unit 1</b>	<b>The science of biology</b>	<b>1</b>
1.1	The methods of science	2
1.2	The tools of a biologist	15
1.3	The relevance and promise of biological science	25
1.4	Biology and HIV/AIDS	30
<b>Unit 2</b>	<b>Biochemical molecules</b>	<b>42</b>
2.1	Inorganic and organic molecules	42
2.2	Inorganic molecules	43
2.3	Organic molecules	52
<b>Unit 3</b>	<b>Enzymes</b>	<b>79</b>
3.1	Nature of enzymes	80
3.2	Functions of enzymes	88
3.3	Factors affecting the functions of enzymes	93
<b>Unit 4</b>	<b>Cell biology</b>	<b>111</b>
4.1	Cell theory	112
4.2	Types of cells	121
4.3	Parts of the cell and their functions	125
<b>Unit 5</b>	<b>Energy transformation</b>	<b>151</b>
5.1	Respiration	152
5.2	How do plants harness light energy in photosynthesis?	170



Contents	
Section	Learning competencies
1.1 The methods of science (page 2)	<ul style="list-style-type: none"><li>• Define science as a way of knowledge and explain it as a way of looking at and thinking about natural events.</li><li>• Describe and explain the main steps that scientists follow when they are investigating something.</li><li>• Demonstrate scientific methods by narrating how Louis Pasteur and Alexander Fleming used the scientific method to solve problems.</li><li>• Plan and conduct an experiment to investigate a particular observation.</li><li>• Write a report for a scientific experiment.</li></ul>
1.2 The tools of a biologist (page 15)	<ul style="list-style-type: none"><li>• Name and describe the function of the main pieces of apparatus that are used by biologists the world over.</li><li>• Describe how these pieces of apparatus work.</li><li>• Explain how, and under what circumstances, these pieces of apparatus would be used and demonstrate the use of some of them.</li><li>• Classify the apparatus as laboratory tools, field tools or both.</li><li>• Be aware of possible health and safety implications of using these tools.</li></ul>
1.3 The relevance and promise of biological science (page 25)	<ul style="list-style-type: none"><li>• Explain how biological science is relevant to food production, health and disease, conservation, and control of the population.</li><li>• Explain the promise of biology in relation to genetic engineering and biotechnology.</li></ul>
1.4 Biology and HIV/AIDS (page 30)	<ul style="list-style-type: none"><li>• Explain how biologists are actively involved in the fight against AIDS.</li><li>• Describe how you can help community efforts to control AIDS.</li><li>• Describe the decisions you will need to take to help control AIDS.</li></ul>

## 1.1 The methods of science

By the end of this section you should be able to:

- Define science as a way of knowledge and explain it as a way of looking at and thinking about natural events.
- Describe and explain the main steps that scientists follow when they are investigating something.
- Demonstrate scientific methods by narrating how Louis Pasteur and Alexander Fleming used the scientific method to solve problems.
- Plan and conduct an experiment to investigate a particular observation.
- Write a report for a scientific experiment.

Scientists investigate natural events to try to find out exactly why and how they happen. To arrive at an answer, they need conclusive evidence that a certain factor causes the event. Very often, this kind of evidence can only be obtained by carrying out experiments. You will learn how to proceed from identifying the problem to planning and carrying out an investigation in such a way that the results will enable you to conclude that the factor you are investigating does (or does not) cause the event to happen. Along the way, you will see how some of the greatest biologists have used this scientific method in their investigations. You will also learn how to write a report on a scientific investigation in such a way that scientists all over the world would be able to instantly recognise the stages in your investigation and carry it out for themselves if they wanted to check your results.

### What is the science of biology?

Biology is the science of life and living organisms. You know from earlier studies that an organism is a living being made from one cell (for example bacteria, unicellular algae) or many cells (for example, animals, plants and most fungi).

*The word biology is derived from two Greek words:*

**bios** – meaning 'life' and  
**logos** – meaning 'study'

When we think of biologists, we often have quite a narrow view of what they do. But, just as all chemists don't wear white coats, all biologists don't look down microscopes in laboratories. Here are just a few of the areas of biological study.

Some biologists become astrobiologists. These biologists engage in all kinds of research to try to find evidence of life on other planets in our Solar System and in galaxies elsewhere in the Universe.

Other biologists take part in biomedical research. These biologists help in many areas, including the development of new drugs and vaccines. They also study the ways in which diseases develop to gain a better understanding of them so that cures can be found.

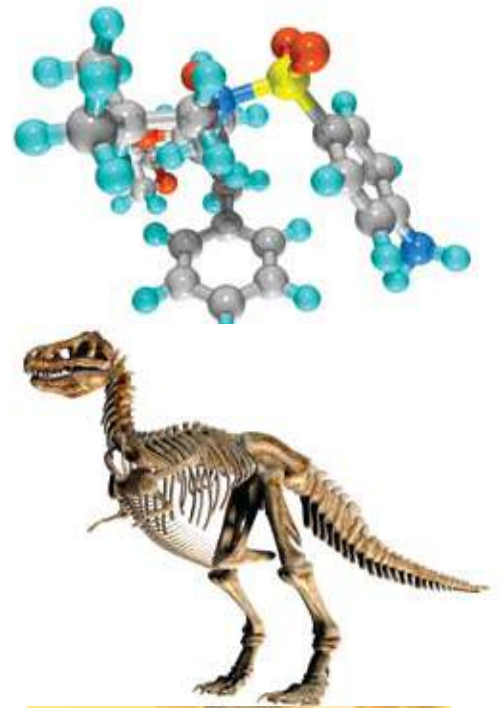
Others still become microbiologists. These biologists study how micro-organisms of all kinds function. Some micro-organisms cause disease, and understanding how they work makes a treatment more likely. Many microbiologists are studying the human immuno-deficiency virus (HIV) to get a better understanding of how AIDS develops and how it can be treated.

Paleobiology is a fascinating area of study to many people. Paleobiologists try to find out more about the way in which life began on Earth and how it has evolved from simple life forms into more complex ones. They use evidence from fossils and from studies of the chemistry of ancient rocks to make estimates of when and how new life forms appeared on the planet.

Many different biologists are involved in the Human Genome Project. This enormous project has produced the first ever map of the 46 chromosomes found in human cells. It has located the tens of thousands of genes and has determined the exact structure of each chromosome. Although the 'map' is finished, there is still much to be found out. Analysis will continue for many years to come.

Besides these biologists, there are others who are, perhaps, more recognisable. These include: doctors, dentists, veterinary surgeons, nurses, physiotherapists, botanists, zoologists, physiologists, biochemists, agricultural biologists, ecologists, ethologists, entomologists, geneticists, oncologists, neurobiologists, parasitologists . . .

. . . and many, many others besides.



*Genetics, paleobiology, biomedics...  
Even trying to find signs of life on  
other planets: it's all Biology!*

## What is science?

The word science comes from the Latin word *scientia*, which means 'knowledge'. But science isn't just about having knowledge: science is a unique system of acquiring knowledge based on the **scientific method**. This science is sometimes called **experimental science**, because it depends very heavily on experimentation to obtain the information. This is different from **applied science**, in which scientific research is used to meet certain human needs. However, it is often difficult to separate the two.

### Activity 1.1: What do you think science is?

Gregor Mendel was a monk and so not obviously 'a scientist'. He was puzzled by the patterns of certain features in the offspring of mice and pea plants. He carried out many carefully controlled breeding experiments with pea plants and, by analysing his results thoroughly, he was able to form the basic laws of how genes are inherited.

Isaac Newton is famous the world over because an apple falling on his head gave him an idea. Why did the apple fall towards the earth and not travel away from the earth into space? After some considerable thought and work, Newton worked out the basic laws of gravitation that apply to all particles and bodies anywhere in the Universe. Naturally, he couldn't test this easily by experiment!

### KEY WORDS

**scientific method** *the process by which scientists approach their work*

**experimental science** *the use of experiments to obtain information*

**applied science** *the use of scientific research to meet certain human needs*

‘Recipe’ for bees: Kill a young bull and bury it in an upright position so that its horns protrude from the ground. After a month, a swarm of bees will fly out of the corpse.

‘Recipe’ for mice: Place a dirty shirt or some rags in an open pot or barrel containing a few grains of wheat or some wheat bran. In 21 days, mice will appear. There will be adult males and females present and they will be capable of mating and reproducing more mice.

People had seen swarms of bees flying from a bull’s carcass and mice emerging from containers containing dirty shirts and cereal. They assumed that, because the two events were linked, that one caused the other. **How could you repeat the ‘mice from shirts’ investigation to show conclusively that the mice did (or did not) come from the shirts?**

Both of these men are ranked as great scientists, yet the work they did seems to be very different. So what is it that allows us to call them scientists? What is science?

Write a short paragraph to explain why we would consider Mendel and Newton to be scientists.

Science is an ongoing effort to find new information and principles which can increase human knowledge and understanding. In their research, scientists collect evidence that supports or disproves a particular suggested explanation of a natural phenomenon. One important idea in science is that any suggested explanation of a phenomenon should be capable of being proved wrong. If there is no way of proving it wrong, how can other people accept that it is correct? This is what distinguishes science from religious beliefs.

### What is the scientific method?

This is the process by which biologists and all other scientists approach their work. For centuries, people based their explanations of what they saw going on in the world around them on observations, without testing their ideas to see if they were true. One ancient belief was that simple living organisms could come into being by **spontaneous generation**. This idea suggests that non-living *objects* can give rise to living *organisms*.

As an example:

- **Observation:** Every year in the spring, the river Nile flooded areas of Egypt leaving behind mud containing many nutrients that enabled the people to grow that year’s crop. However, along with the muddy soil, large numbers of frogs appeared that weren’t around in drier times.
- **Conclusion:** Muddy soil gives rise to frogs!

Also, before the invention of the refrigerator, animal carcasses were hung by the heels in butcher’s shops and people would ask the butcher to cut off the part they wanted. The shop was always full of flies. So people believed that the meat had turned into flies!

Because of these and other observations, many people, including quite eminent ‘scientists’ of the day, produced recipes for ‘creating’ life from non-living objects. It took the work of Louis Pasteur using the proper scientific method to finally disprove this myth.

Read the information and question in the box on the left and think about how you would test whether an explanation is true or false.

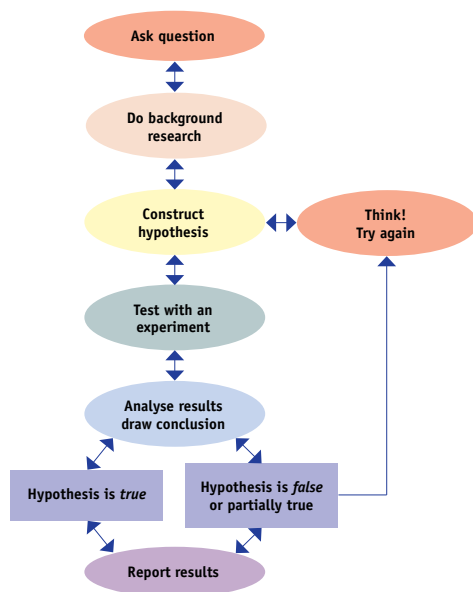


Figure 1.1 The scientific method

### What are the main steps of the scientific method?

The scientific method consists of a number of stages. These are summarised in the flowchart.

So what is happening at each of these stages? What is the biologist doing and what do we mean by **hypothesis**?



To help you understand what is happening at each stage of the scientific method, an example using the growth of a tomato seed is detailed below.

**Table 1.1** How a biologist would follow the scientific method

Step of the method	What happens at this step
Ask a question	Something catches our imagination. We know that tomato seeds germinate when they are planted. But, why don't tomato seeds grow inside tomatoes?
Do background research	Before we start trying to do the whole investigation ourselves, we will first check scientific magazines and the internet to see if anyone else has looked into the problem, or into a similar problem. We find out that there are substances in plants that control growth, called growth regulators.
Construct hypothesis	<p>'There are chemicals in tomatoes that stop the seeds from growing whilst they are still in the tomatoes themselves.'</p> <p>This hypothesis is testable by an experiment. We think that it is a chemical that is responsible. So how do we prove that? We could try covering some seeds with tomato juice and others with water and see if any germinate. Based on our hypothesis, we can make a <b>prediction</b>: 'Seeds covered in tomato juice will not germinate as well as seeds covered in water.'</p>
Design and carry out an experiment to test the hypothesis	<ol style="list-style-type: none"> <li>1. Put several tomatoes in a blender.</li> <li>2. Filter (strain) the blended material through some muslin.</li> <li>3. Collect the tomato seeds and wash them in distilled water.</li> <li>4. Place 20 in a Petri dish on filter paper and cover them with the tomato juice obtained from filtering the tomatoes.</li> <li>5. Place 20 in a Petri dish on filter paper and cover them with the same volume of distilled water.</li> <li>6. Place them in a growth cabinet that will keep the temperature and lighting conditions constant.</li> </ol>

## KEY WORDS

**spontaneous generation** *the appearance of living organisms from non-living matter*

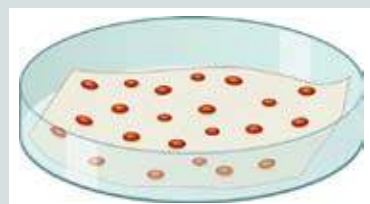
**hypothesis** *an educated guess about what a biologist thinks the explanation of an observation will be. But it has to be stated in such a way that it can be tested by an experiment*

**prediction** *an educated guess as to how the biologist thinks his/her experiment will turn out*



**Figure 1.2** Tomato seeds don't germinate inside tomatoes. What's stopping them?

A hypothesis that said 'There is *something* in tomatoes that stops seeds germinating' would be too vague and we couldn't test it by experiment.



Filtering removes all the cells. Washing in distilled water means that there are no chemicals on the seeds at the start of the experiment. A Petri dish is a convenient container. Filter paper inside can hold water for the seeds. Placing equal numbers of seeds in each and keeping them in the same conditions makes it a 'fair test'. The only difference between them is the chemicals in the tomato juice.

*Continued*

Any difference in the results must be due to this difference in the two conditions. The seeds that were covered only in distilled water form the **control** group. This is a standard against which we can compare. If we had just used the **experimental** group (the ones covered in tomato juice), we would have had nothing to compare them with. We wouldn't have known whether or not germination was the same, better or worse than normal.

**Control group and experimental group**

A control group acts as a 'standard' for comparison. It is used to 'isolate' the factor we are investigating and show that changes are due to this factor. For example, in drug trials, one group of people with the condition the drug is used to treat is given a tablet containing the drug (the experimental group). Another group is given a placebo – a tablet containing no drug (the control group). If both groups get better, then it seems that the drug is having little effect. If only the experimental group get better, this must be due to the drug. Without the control group we wouldn't have been sure.

	<p>7. Leave them for four days.</p> <p>8. Check the number that have germinated in each condition.</p> <p>9. Repeat the experiment 50 times to confirm your results.</p>
Analyse results and draw conclusions	<p>Out of 1000 seeds sown in each condition, 668 germinated in the distilled water (13.36 per dish) and 265 germinated in the tomato juice (5.3 per dish). It seems like something in the tomato juice is affecting the germination of the seeds. It can't be the cells themselves, because they were filtered off. It must be a chemical in the juice.</p>
Accept or reject the hypothesis	<p>It seems as though the hypothesis is along the right lines; the tomato juice will only contain chemicals, not cells, and it does reduce the amount of germination. So we accept the hypothesis. But inside the tomatoes themselves, none of the seeds germinate. There is a bit more work to do yet!</p>
Report results	<p>We must now decide whether or not to report the results to other biologists. Someone else might decide to take the work further and try to isolate a particular chemical from the many in the juice to find exactly what is stopping them from growing inside the tomato itself.</p>

The next section of this unit gives some case studies taken from the experiences of some scientists.

**KEY WORDS**

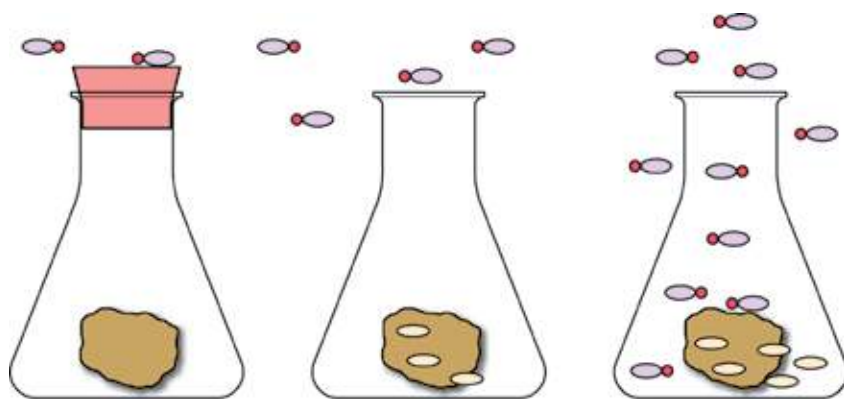
**control group** *the standard group in an experiment in which the experimental groups are compared with*

**experimental group** *the group in an experiment which is being experimented on in order to compare with the control group*

**How did the scientific method disprove the idea of spontaneous generation?**

What about the belief that rotting meat produces flies? How could you disprove that by using the scientific method? Well, in 1668 an Italian biologist, Francesco Redi, did just that. Many scientists consider this to be the first true 'experiment'. He used wide-mouth jars containing meat. Some jars were left open to the air. Others were covered with a piece of gauze.

After several days, maggots and then flies could be seen in the open jars, but none appeared in the closed jars.



**Figure 1.3** Francesco Redi's 1668 experiment

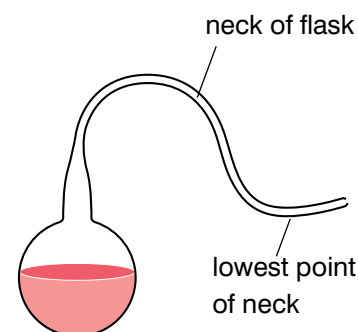
Redi hypothesised that only flies could produce more flies and predicted that, in his experiment, flies would be found in the open jars, but not in the covered jars. He maintained all the jars under the same conditions and so he controlled many variables. By choosing to cover some jars with gauze rather than an impermeable seal, he allowed air to enter all the jars – again he controlled a variable that could have affected the outcome of the experiment. His results matched his prediction and when other people tried the experiment, they too got the same results. Redi was able to conclude that flies cannot be produced from rotting meat. He also went on to say that it was unlikely that any form of spontaneous generation was possible.

Most people accepted this for larger organisms, but, at round about this time, the microscope had been invented and the whole world of microbiology was opened up. Many people still believed that micro-organisms could arise by spontaneous generation. It took the work of Louis Pasteur to disprove this. In 1859, Pasteur carried out experiments to show that the micro-organisms that caused wine and broth to go cloudy came from the air and were not made from the broth itself. He used special 'swan-necked flasks' like that shown in Figure 1.4.

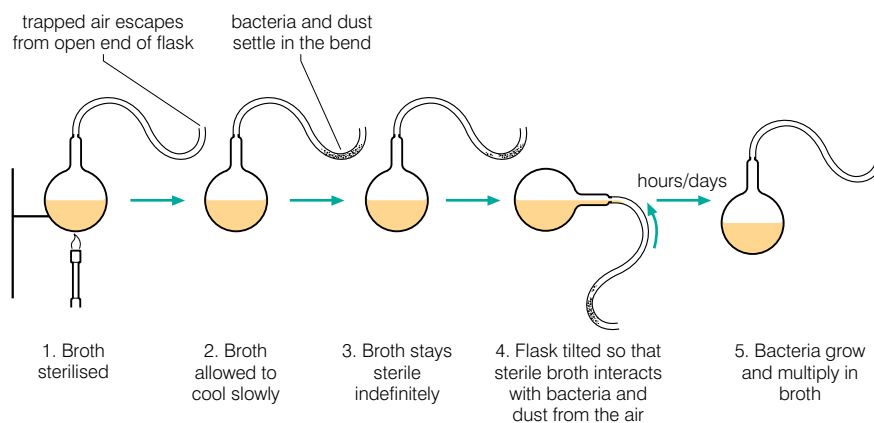
Pasteur boiled broths in swan-necked flasks to kill any micro-organisms that might be in them. The boiling forced steam and air out of the flasks. When the boiling stopped and the broth cooled, air was sucked back into the flasks. Some contained a filter to prevent all solid particles from getting into the growth medium from the air. Others had no filter but, in these, the dust (and the micro-organisms) in the air settled in the lowest part of the neck of the flask. All the flasks were kept under the same conditions in Pasteur's laboratory.

Pasteur found that the broths stayed clear for months. At the end of this time, he treated the flasks in one of three ways:

- He left some of them as they were.
- He broke the necks on some.
- He tilted others to allow the dust in the low part of the neck to mix with the broths.



**Figure 1.4** A swan-necked flask like the ones used by Louis Pasteur



**Figure 1.5** A summary of Pasteur's procedure

**KEY WORDS**

**independent variable** *the variable that the experimenter changes to see if this affects the performance of the dependent variable. Does the presence or absence of a drug in a tablet (independent variable) affect the recovery of the patient?*

**dependent variable** *the factor in an experiment that the scientist measures to see if it changes when the independent variable is changed*

The broths in the second two groups of flasks turned cloudy (due to the presence of micro-organisms) within days. The broths in the first group remained clear. After this, people were forced to admit that spontaneous generation, even of micro-organisms, could not happen.

**Activity 1.2 Pasteur's work**

Pasteur's work is another good example of the scientific method at work. See if you can identify the various stages.

1. What do you think might have been Pasteur's hypothesis?
2. Outline the plan of his experiment. Did he have any controls?
3. What do you think he might have predicted?
4. Did his results support his prediction?
5. What conclusion was he able to draw?

One stage in the scientific method is to 'do background research'. Pasteur certainly did that. He knew that other scientists had tried to disprove spontaneous generation before him and he was able to draw on the results of their experiments and improve their technique.

**What do we mean by cause and effect?**

Scientific experiments try to establish cause and effect. This means that they try to prove that a change in one factor brings about a change in another factor. The factor that the scientist changes, or manipulates, is called the **independent variable** (or **IV** for short). The factor that the scientist measures to see if it changes when the IV is changed is called the **dependent variable** (or **DV** for short). The scientist will want to find out if changes in the independent variable produce changes in the dependent variable. In the example on pages 5 and 6, the independent variable was the presence or absence of tomato juice. The dependent variable was the number of tomato seeds germinating.

To prove cause and effect – to prove that it is changes in the IV (and nothing else) that are causing changes in the DV – we must

**Activity 1.3 Library search**

Do a library search to find out about the work of Lazzaro Spallanzani. How do you think his work influenced Pasteur?

take all the steps we can to ensure that the experiment is a **fair test**. We must make sure that any other factors which could affect the results are the same for the different conditions we set up. In the tomato seed example, if one group of seeds had been at a higher temperature than the other group, this could have made them germinate faster. We wouldn't have known whether it was the tomato juice affecting the results or the temperature. Our experiment would not be valid. So we must keep constant anything other than the IV that might influence the results. These are **controlled variables**. In the tomato seed experiment, the controlled variables were:

- temperature
- lighting conditions
- number of seeds per dish, and
- volume of liquid added (water or tomato juice).

Occasionally, there is a variable that might influence the results that you can't control. Such a variable is a **confounding variable**. This is because it 'confounds' the interpretation of the results. You couldn't be certain that it was the IV producing the changes in the DV because of the presence of the confounding variable.

For example, if you measure the carbon dioxide uptake by wheat plants as the light intensity changes over the day, you cannot control the effect of change in temperature. It could be a confounding variable.

## Accuracy, reliability and validity in scientific experiments

People often confuse these ideas, but they are really quite separate notions and all are important to how well an experiment is received by other scientists.

### Accuracy

**Accuracy** refers to how precisely you measure or count something. For example, you could measure time with a clock, a wristwatch or a stop-clock accurate to 0.01 seconds. The level of accuracy you choose must reflect the magnitude of what you are measuring. You don't always need the most accurate measuring instrument. For example, if you were timing a reaction that was likely to last a few minutes at most, the stop-clock would be the best choice. But if you were timing something that lasts several hours, you just don't need that level of precision and it might even be a hindrance – by measuring the seconds accurately, you might lose track of the hours!

To measure volume, you could use:

- a syringe
- a measuring cylinder
- a pipette
- a burette

### KEY WORDS

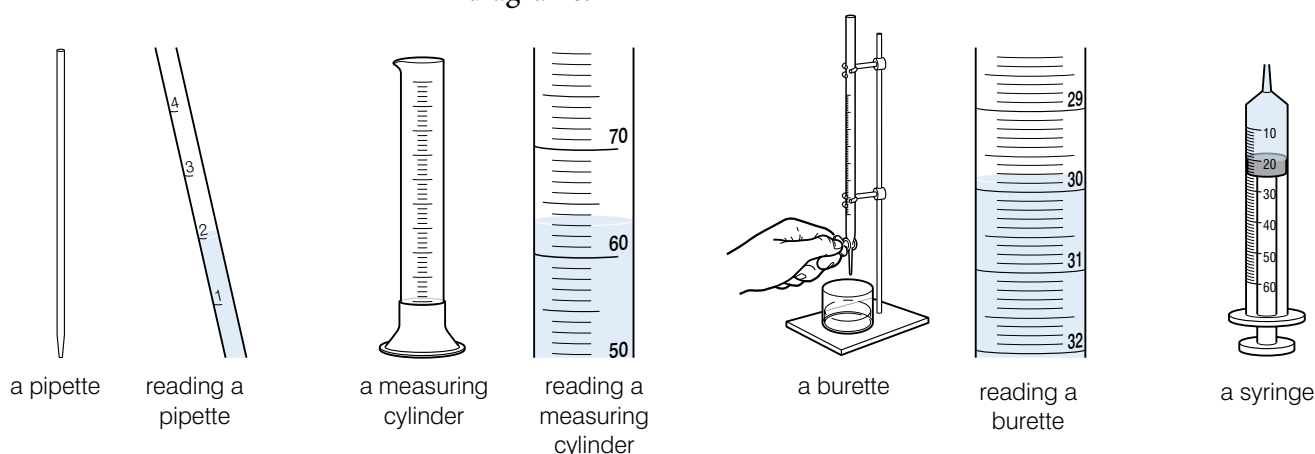
**fair test** *an experiment in which the only difference between different repeats of the experiment is the different values of the independent variable, all other factors that could affect the outcome have been kept constant (they have been controlled)*

**controlled variables** *factors other than the independent variable that are kept constant in order to avoid influencing results*

**confounding variable** *a factor that can't be controlled which may influence the result of the experiment*

**accuracy** *how precisely something has been measured or counted*

All of these come in various sizes. Look at the ones shown in the diagrams.



**Figure 1.6** Different measuring apparatus

### KEY WORDS

**reliability** *a measure of how dependable and consistent the results of an experiment are*

**anomalous results** *are really odd results that do not fit the general pattern*

**colorimeter** *measures how much light passes through a liquid*

### Activity 1.4

Which apparatus would you use to measure out 36 cm<sup>3</sup> of water?

To measure 3.5 cm<sup>3</sup> accurately, the pipette would be best.

To measure 200 cm<sup>3</sup> you would use the measuring cylinder. This one holds 100 cm<sup>3</sup> and so you would have to fill it twice. The burette would be more precise, but less convenient and would you need the extra precision on quite a large volume?

### Reliability

**Reliability** is a measure of how dependable our results are. If we were to repeat the investigation, would we get more or less the same results? There are several things we can do to increase the reliability of our experiments.

- We can standardise all our procedures, so that we always do exactly the same thing. This makes it much more likely that we will be able to repeat our results.
- We can repeat it many times ourselves. This allows us to see, hopefully, a general pattern. It also allows us to:
  - spot any **anomalous results** and, if it is justified, to exclude these
  - calculate an average result, which is likely to be more representative than any individual result
- We can try not to use personal judgement. For example, if in a given experiment we have to wait until a solution turns a certain shade of red, one person's judgement will almost certainly differ from the next person's. There are ways around this:
  - We can have a 'standard' to compare our experiment to. In other words, something containing the chemical that is the exact colour we need it to be. This helps, but we must still make a judgement.
  - We can use a special apparatus called a **colorimeter**. This measures how much light passes through a liquid. It is nearly always better to *measure* than to *judge*.

## Validity

This is about whether or not our experiment measures what it says it is measuring. In the tomato seed experiment, we said that our results were due to the presence or absence of tomato juice. For our experiment to be valid, we must be certain that our results were only due to the changes in the independent variable and nothing else. So had we not controlled all the other variables, our experiment would not have been valid.

### Activity 1.5: Planning investigations

Now it's your turn! Plan experiments to investigate the following observations:

1. When a winemaker used lactose (milk sugar) instead of sucrose (ordinary table sugar) the wine he made tasted like fruit juice. (*Hint: you need to know how well the yeast is fermenting the two sugars.*)
2. In the area near an old copper mine, no plants grow. Go further away and more and more plants are growing. An analysis of the soil near the mine found that there was an unusually high concentration of copper dissolved in the water in the soil. (*Hint: remember plants grow from seeds!*)
3. The leaves of plants wilt more quickly on a hot day than on a cooler day. (*Hint: think what you lose more of on a hot day than a cool day.*)

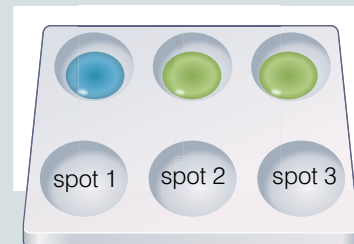
Don't forget, you will need to have:

- a hypothesis (from which you can make a prediction)
- a plan, containing:
  - a clear method of changing the independent variable
  - a clear method of measuring the dependent variable
  - methods of controlling other potentially confounding variables
  - methods of ensuring appropriate levels of accuracy, reliability and validity

### How do we write reports on scientific experiments?

When biologists write a report on an investigation they have just done, they write it with a view to having it published in a scientific journal, such as *Nature* or *Science*. These journals are read by many other biologists who will want to understand their work and, perhaps, repeat it to check on the results. It is important, then, that the layout of the report is recognisable to everyone and understandable by everyone. So, there is a set way to lay out such a report. It is not always identical in every case, but there are certain 'rules' to follow.

### Example



**Figure 1.7** Using a standard to compare colour changes

In the investigation demonstrated above we are waiting for the chemical to change colour from being blue (as in the first spot) to the same yellow as that in spot 3. Clearly, spot 2 hasn't quite got there. The experiment isn't quite over yet. But without the 'standard' to compare against, we might have thought that it was. However, it would be even more reliable if we measured it in a colorimeter.

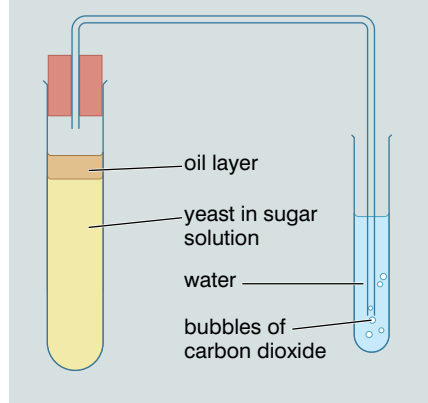
### Activity 1.6 Spotting anomalous results

Which is most likely to be an anomalous result in the following table? Explain your reasoning.

Temperature (°C)	Enzyme activity (%)
5	3
10	17
15	36
20	55
25	42
30	85
35	97

Experiments can be reliable without being necessarily valid. If you consistently omit the same important step (for example, consistently forget to control the same variable), you may well keep getting the same results. But they will be the wrong results and your experiment will not be valid.

You can measure the rate of fermentation of yeast using simple equipment as shown in the diagram below. You can count the number of bubbles of carbon dioxide produced in five minutes and work out a rate per minute.



There must be:

- a title, which states clearly what is being investigated
- a hypothesis, stated clearly in terms of how the independent variable is expected to influence the dependent variable, often extended to a prediction for the particular experiment
- a clear description of the experimental procedure; this must be in such detail that anyone of the same level of understanding could easily replicate the procedure and it must include:
  - the apparatus used (a diagram of the assembled apparatus is useful)
  - details of any chemicals used; what volumes or concentrations or masses were used
  - details of any organisms used (for example, yeast, mice) – what strain and how many
  - details of any control experiments
- a full account of the results obtained; it is often helpful to summarise these (where appropriate) in graphs, charts and tables
- the conclusions that have been drawn from the results
- an evaluation of the procedure; this is an honest assessment of the limitations of the procedure that has been used, pointing out any unavoidable limitations and inaccuracies that arose
- an acknowledgement of the use of any other person's work; this is usually done by identifying by a number the place in the report where other work has been used, and then listing the sources at the end of the work

So, for the tomato seed experiment, the report could look something like this:

Section	How it would be written
Title	An investigation into the effect of tomato juice on the germination of tomato seeds.
Hypothesis	A chemical in tomato juice inhibits the germination of seeds.
Prediction	Seeds covered in tomato juice will germinate less well than seeds covered in distilled water.
Procedure	<p>30 tomatoes were blended for five minutes.</p> <p>The blended material was then filtered through some muslin and the liquid (juice) was collected. The seeds were extracted from the cellular material, which was then discarded.</p> <p>The juice was diluted with distilled water to give a total volume of 550 cm<sup>3</sup>.</p> <p>The tomato seeds were washed in distilled water for 30 seconds, to remove any chemicals from their surface. They were dried briefly on filter paper.</p> <p>100 Petri dishes were prepared by placing a piece of filter paper in each. Each piece of filter paper had a 0.5 cm grid drawn on it.</p>



	<p>20 seeds were placed in each Petri dish on the intersections of the lines of the grid (to ensure even spacing in all dishes).</p> <p>10 cm<sup>3</sup> tomato juice was added to half of the Petri dishes and 10 cm<sup>3</sup> distilled water was added to the other half.</p> <p>All the dishes were placed in an incubator at a temperature of 20 °C for four days.</p> <p>At the end of this time the number of successful germinations in each dish was recorded and means for each condition were calculated. If a radicle (root) of 0.5 cm or more was present, the seed was said to have germinated.</p>
Results	Out of 1000 seeds sown in each condition, 668 germinated in the distilled water (13.36 per dish) and 265 germinated in the tomato juice (5.3 per dish).
Conclusion	The hypothesis is accepted. The germination of the seeds in the tomato juice is much less successful than in distilled water. Some chemical in the tomato juice must therefore be inhibiting the germination. In tomato fruits, no seeds germinate, but it must be remembered that in our investigation, the juice had been diluted to give sufficient volume for 50 replicates of the investigation.
Evaluation	<p>There were no anomalous results. The germination of seeds in all of the dishes in the experimental condition (the tomato juice) was less successful than in the dishes in the control condition (distilled water).</p> <p>The experiment was not without limitations.</p> <ul style="list-style-type: none"> <li>• It was only carried out for four days (to limit the development of fungal growth that might have interfered with germination). Had it been carried out for longer, the pattern may have been different.</li> <li>• It was only carried out at one temperature; this may have influenced the experimental and control conditions differently. Repeating the investigation at a range of temperatures would help to clarify this.</li> <li>• The judgement of germination (a radicle of 0.5 cm length) was somewhat arbitrary, but it did overcome the problem of including in the count seeds that had merely swollen with water but not produced any growth.</li> </ul> <p>We are of the opinion that these limitations had only a minor effect on the validity and reliability of this experiment.</p>
Acknowledgements	<i>Biology</i> – Martin Rowlands – information on plant growth regulators.

The above report has been tabulated for your ease of understanding. An actual report in a scientific journal would not be tabulated, although it would have many of the headings shown here.

### Activity 1.7: Writing a report on an experiment

Write a report in this format as though you were Louis Pasteur and had just carried out the investigation that was to finally disprove the idea of spontaneous generation. Try to incorporate as much detail as possible so that anyone could follow your description of the procedure and repeat the investigation. Think of a way of presenting the results so that it is immediately obvious what happened. Don't forget to explain your conclusions and to write an evaluation.

**Activity 1.8**

A scientist observes that crocodiles often fight and bite each other. Their teeth are covered in bacteria yet crocodiles rarely get infected bites. Brainstorm how a scientist would develop and test a hypothesis to explain this observation. Turn your observations into a flowchart of the process.

**Review questions**

Choose the correct answer from A to D.

- Which of these *best* describes what science is?
  - a body of knowledge
  - a way of doing experiments
  - a way of looking at and thinking about the natural world
  - a series of ideas
- The scientific method involves:
  - putting forward hypotheses in a form that can be tested
  - carrying out experiments
  - analysing results and drawing conclusions
  - all of these
- Which of the following is NOT a type of biologist?
  - geneticist
  - entomologist
  - astrophysicist
  - doctor
- Scientists often use statistics when drawing conclusions because:
  - statistics are more accurate than human opinion
  - statistics are more reliable than human opinion
  - statistics are infallible
  - none of these
- The independent variable in an experiment is the variable that:
  - is measured by the experimenter
  - is controlled by the experimenter
  - is changed (manipulated) by the experimenter
  - upsets the reliability of the results
- The dependent variable in an experiment is the variable that:
  - is measured by the experimenter
  - is controlled by the experimenter
  - is changed (manipulated) by the experimenter
  - upsets the reliability of the results
- Having a control condition in an investigation:
  - gives a 'standard' to compare against
  - increases the validity of the experiment
  - increases the reliability of the experiment
  - both A and B

8. Publishing reports of biological investigations in scientific journals is important because:
- A it allows biologists all over the world to understand your reports
  - B it allows biologists all over the world to repeat your investigations
  - C it allows biologists all over the world to challenge your results
  - D all of the above
9. The scientific method is more reliable than opinion based on personal observation because:
- A scientists are more reliable than other people
  - B the scientific method involves gathering information from controlled experiments to prove or disprove a hypothesis
  - C observation is not a valid scientific technique
  - D scientific method always gives the correct answer
10. The reliability of an experiment is increased by:
- A carrying out repeat experiments
  - B minimising personal judgement
  - C working as quickly as possible
  - D using the most appropriate apparatus

## 1.2 The tools of a biologist

By the end of this section you should be able to:

- Name and describe the function of the main pieces of apparatus that are used by biologists the world over.
- Describe how these pieces of apparatus work.
- Explain how, and under what circumstances, these pieces of apparatus would be used and demonstrate the use of some of them.
- Classify the apparatus as laboratory tools, field tools or both.
- Be aware of possible health and safety implications of using these tools.

In this section you will be reviewing the nature and function of some basic 'tools' or pieces of apparatus of a biologist. Some of these you will have met before, others may be new to you. You will learn about the sort of tools that are needed in the laboratory and those that are needed when working in the field. Some pieces of apparatus are used in both situations.

**Activity 1.9**

Look at the list of basic tools which biologists use in the laboratory. Copy the list and write down what you would expect each piece of equipment to be used for.

**What apparatus do biologists use?**

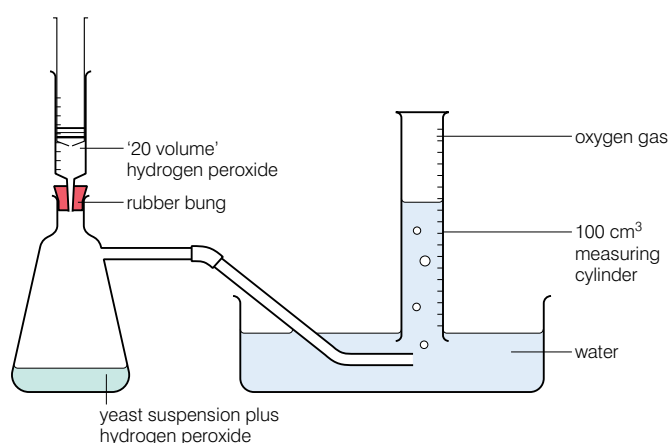
How much time do you have? You only need consult the catalogue of a supplier of biological apparatus to see that the list is a pretty long one! However, we shall not be considering all the various sizes of test tubes or the different kinds of Bunsen burner or the different kinds of electronic equipment now available for biologists. We shall confine ourselves to the main items of field and laboratory equipment that biologists everywhere would recognise and be able to use.

**What do biologists use in the laboratory?**

This is still a large list. But there are some basic tools. These include:

- microscopes
- dissecting equipment
- Petri dishes
- pipettes and syringes
- centrifuges
- measuring cylinders
- balances

We have already considered measuring cylinders, pipettes and syringes when looking at the idea of 'accuracy' in scientific experiments. All these are used for measuring volumes, usually of liquids, but in some investigations they can be used to measure the volume of a gas. In this example, an upturned measuring cylinder is being used to collect oxygen gas produced when yeast converts hydrogen peroxide into water and oxygen.



**Figure 1.8** Using a measuring cylinder to measure the volume of oxygen produced when yeast decomposes hydrogen peroxide

Some syringes are designed specifically as 'gas syringes' and could be used as an alternative way of collecting the oxygen in the above experiment.

**Balances** are used for measuring mass. They come in a range of sizes and properties. Some can measure the mass of very heavy

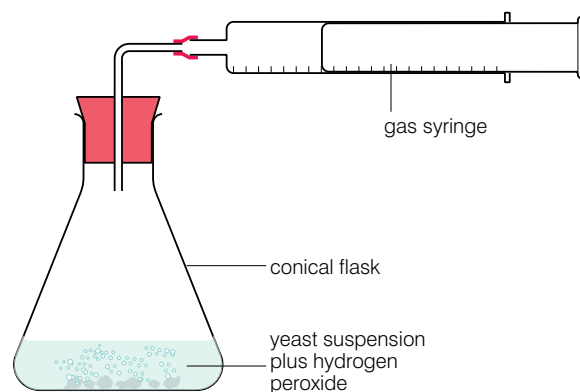
**KEY WORDS**

**balances** apparatus used for measuring mass

**dissect** to cut apart or separate tissue for anatomical study

objects, but not with any great degree of precision. Others measure smaller masses to the nearest 0.0001 g (one ten-thousandth of a gram).

Sometimes biologists need to **dissect** specimens to find out what they are like inside. This need not always mean dissecting a whole organism. Quite often, students dissect organs, such as the heart or the kidney, to find out about their structure. Biologists may dissect owl pellets – these are pellets containing the parts of food that the owl has eaten and that cannot be digested and have been regurgitated. Dissecting these can give information about what the bird has been eating.



**Figure 1.9** Using a gas syringe to measure the volume of oxygen produced when yeast decomposes hydrogen peroxide



A

**Figure 1.10A** This balance is accurate to 0.01 g



B

**Figure 1.10B** This balance is accurate to 0.0001 g.

Figure 1.11 shows a standard dissecting kit containing a magnifying glass, scalpels, scissors, forceps (tweezers) and mounted needles. Figure 1.12 shows a student dissecting a frog. The student is using a scalpel to cut away the skin and reveal the abdominal organs. These can then be removed and studied individually.

### DID YOU KNOW?



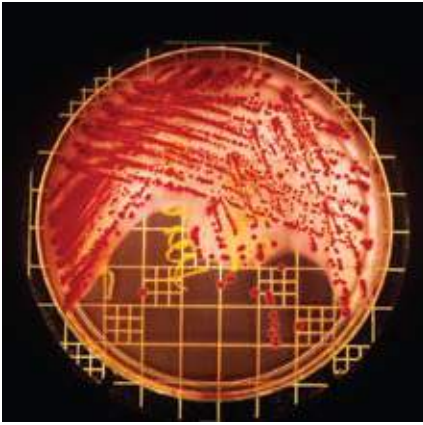
Sometimes small specimens are dissected under a microscope. This biologist is dissecting insects using a dissecting **microscope**. The magnification is not as great as other microscopes, but the image is very clear and allows delicate dissection to be carried out. Such work is necessary to help to classify new species of insects.



**Figure 1.11** A standard dissecting kit



**Figure 1.12** Dissecting a frog



**Figure 1.13** Bacteria growing on agar in a Petri dish. The grid allows biologists to work out what proportion of the Petri dish is covered with each type of bacterium.

**KEY WORDS**

**agar** jelly-like substance obtained from seaweed, used for culturing micro-organisms in a Petri dish

to **culture** organisms means to grow them under special conditions that are likely to help their growth



**Figure 1.14** Plantlets or 'explants'

This technique of growing plants from just a few cells on special agars in Petri dishes is called **micropropagation**. It allows thousands of plants to be produced from just one 'parent' plant. All the plants produced are genetically identical.

Petri dishes are round dishes made from glass or from plastic. They are used in many different ways, but usually to culture some organisms.

They are often filled with a 'jelly' called **agar** and used to **culture** bacteria. There are many different agars containing different balances of nutrients. Each type of agar can encourage the growth of different bacteria. By marking a grid on the surface of the Petri dish, biologists can estimate how much of the dish is covered by bacteria and then use this to estimate how fast the bacteria are growing.

Petri dishes are also used to propagate or culture plants. The small 'plantlets' or 'explants' in figure 1.14 have been grown on a special agar from just a few plant cells. They will grow roots and then shoots and leaves. When they are big enough, they will be transplanted into pots of soil or compost and grown into mature plants.

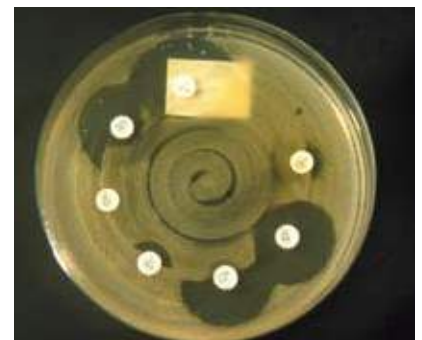
Petri dishes can also be used to:

- show how effective different antibiotics are against certain types of bacteria
- show how well different concentrations of enzymes digest a substance

This Petri dish has one type of bacterium growing all over it – except in some of the areas near the white discs. These discs contain different antibiotics. The clear zones around the discs are areas where no bacteria are growing. Clearly some antibiotics are more effective against this bacterium than others.

This Petri dish contains agar mixed with starch. There are several 'wells' in the agar which contain a starch-digesting enzyme. The whole area has been stained with iodine, which turns blue-black when it reacts with starch. The clear areas around the wells show that the enzyme has diffused out of the wells and digested the starch.

As you know already from your study in grade 9, microscopes are one of the most vital tools in a biology laboratory. There are two main types:



**Figure 1.15** Bacteria being cultured on agar in a Petri dish with several different antibiotic discs



**Figure 1.16** 'Starch-agar' with four 'wells' cut in the agar; each well contains a different strength of enzyme solution



**Figure 1.17** A A light microscope;  
B An electron microscope

- **optical microscopes** that use beams of light to produce magnified images
- **electron microscopes** that use beams of electrons to produce magnified images

You are unlikely ever to use an electron microscope, simply because of cost. Light microscopes vary from basic microscopes that can be used in the laboratory and even taken out and used in the field to very sophisticated microscopes that are linked to image-enhancing computer programs to produce all kinds of images that help to make the image clearer.

Of course, biologists also use electron microscopes that give much higher magnifications and, importantly, much higher resolution, so that more detail can be seen.

### Activity 1.10

In the photograph in figure 1.16, which well do you think contains the most concentrated enzyme?

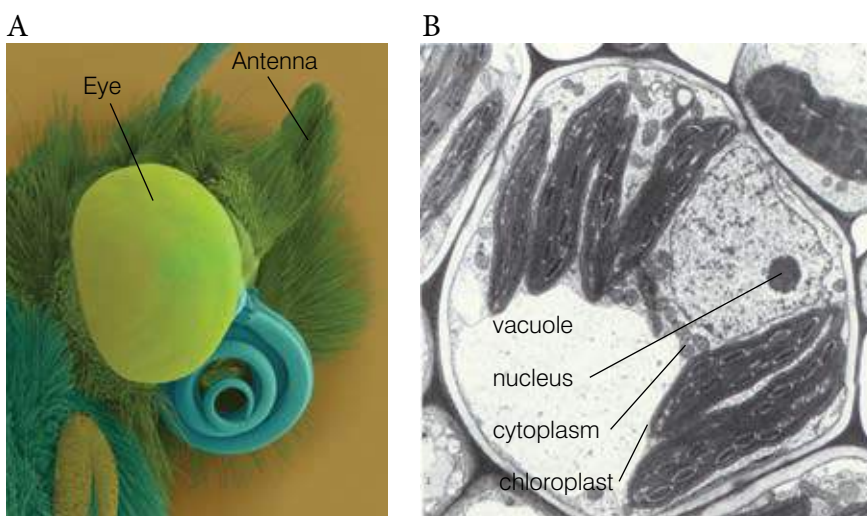
### DID YOU KNOW?

Resolution is the ability to distinguish between two points that are close together. If resolution is poor, they will merge into one point and the detail of the image will be limited. Electron microscopes have a much higher resolution than optical microscopes.

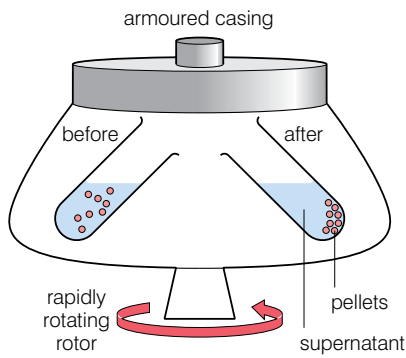
### KEY WORDS

**optical microscope** uses beams of light to produce magnified images

**electron microscope** uses beams of electrons to produce magnified images



**Figure 1.18** A SEM of the head of a monarch butterfly;  
B TEM of a cell from the leaf of a tobacco plant



**Figure 1.19** A centrifuge

**KEY WORDS**

**centrifuge** machine that spins to separate solids from liquids

**quadrat** a small frame used for ecological or population studies

Transmission electron microscopes allow researchers to view the structure of cells in great detail. The transmission electron micrograph (TEM) of the cell from the leaf of a tobacco plant in figure 1.18B shows six large chloroplasts, the vacuole of the cell and the nucleus and cytoplasm. Scanning electron microscopes do not see ‘into’ cells in the same way, but create images of the surface of a specimen by scanning it with a high-energy beam of electrons. Computer programming allows the different parts to be ‘false coloured’ for clearer interpretation. This is shown in the scanning electron micrograph (SEM) of the head of a monarch butterfly, figure 1.18A.

**Centrifuges** are used to separate solids from liquids where simple filtration is not adequate for the task. Some solid particles are very tiny and float around in a liquid, although they are not properly dissolved in the liquid.

Centrifugation can separate these solid particles from the liquid without the need to filter. The mixture is placed in a ‘centrifuge tube’ and placed in the centrifuge. The centrifuge then spins the tubes at high speed. As the tubes spin, the gravitational forces on the solid particles force them to the bottom of the tube. Some centrifuges, called ‘ultracentrifuges’, can spin really fast and cause extremely light particles to fall to the bottom of the tube. These ultracentrifuges are used to separate the various components of animal and plant cells. Centrifugation is commonly used in hospitals for stool tests where the ability to separate particles quickly and clearly is very useful.



**Figure 1.20** Students recording the contents of a quadrat

**What do biologists use in the field?**

Biologists do a lot of work outside the laboratory. They study different areas to find out how the animals, plants and micro-organisms interact with each other and with the environment. They find out how an area changes over time and how it is influenced by human activity. All this involves:

- taking measurements of the abundance of organisms in the field
- taking samples of the environment (for example, soil, rocks, water) for analysis in the laboratory
- collecting specimens for identification and analysis in the laboratory

To gain an estimate of the abundance of organisms in an area, biologists often use **quadrats**. There are many different types, but the simplest is just a metal square. It is placed randomly on the ground and the organisms found inside it are counted and the numbers and types recorded. This data can be used to make an estimate of the abundance of the organisms in the area. Figure 1.20 shows students recording the contents of a quadrat.



**Figure 1.21** Using a quadrat underwater

The use of quadrats is not confined to sites on land. They can be used underwater also!

Biologists also use quadrats to show how the numbers of a particular species changes across an area. To do this, they lay down

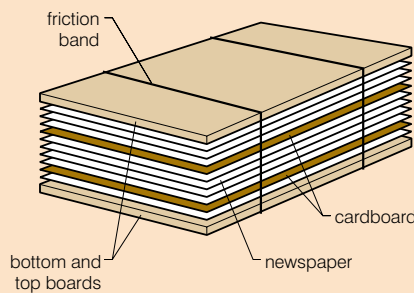


a tape measure (or a long rope marked off every metre) across the area. This is called a **transect line**. They then place the quadrat by the side of the transect line and record the abundance of the organisms in the quadrat. They repeat this every metre, or every 5 or 10 metres, depending on the length of the transect. This gives a picture of how the abundance of each species changes across the area.

To collect specimens for identification in the laboratory, biologists use a range of equipment. Collecting plants is relatively easy, if they are not too large. Small parts (for example, leaves and flowers) can be collected and kept in reasonable condition for a short period in plastic jars or plastic bags. Parts of plants can also be preserved using a plant press. This preserves the shape and form of the plant parts for some time and specimens can be analysed later. Whole plants can be dug up and replanted for study in the laboratory.

### Activity 1.11: Making a plant press

A plant press does not need to be an expensive item of equipment. You can make a plant press using corrugated cardboard, newspaper and some thin rope or string. The newspaper separates individual specimens and the cardboard provides support and allows the press to be tied tight to keep the specimens flat.



### Using a quadrat

If your quadrat measures  $1\text{ m} \times 1\text{ m}$ , it has an area of  $1\text{ m}^2$ . Suppose you place the quadrat 20 times, and find that species A occurs, on average, 3.5 times per quadrat. You can now make an estimate of how many individuals of species A are in the location you are investigating. Suppose the area of this location is  $500\text{ m}^2$ . Your records say there are 3.5 per  $\text{m}^2$  so the total number must be  $500 \times 3.5 = 1750$  in the location you are investigating. The quadrats should be laid at **random** so there is no **bias**. This means you not *choosing* where you will place them, but using some other method to place them. Biologists usually use a system of random numbers from a calculator to specify at which points to place the quadrats within an area.

However, animals pose a different problem. Because they move, they must be caught. Biologists do this in many different ways. Some insects can be caught using nets like the ones shown in Figure 1.22. Others are caught using **pitfall traps** – see page 22.



Figure 1.22 Students using nets to collect and study insects

### KEY WORDS

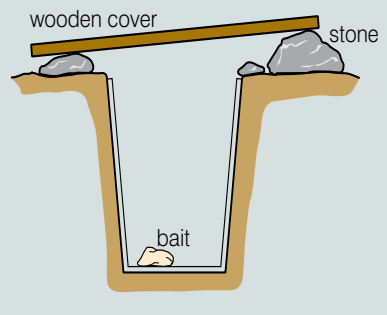
**transect line** a straight line through an area

**random** having no specific pattern, purpose or objective

**bias** tending towards a specific result

**Pitfall traps**

Pitfall traps come in a range of shapes and sizes. This simple one is just a plastic carton sunk into the soil. It would be covered with wood to keep it dark and dry and also keep any animals that fall into it out of sight of predators.



Many night-flying insects are attracted to light. A strong light bulb hung in front of a vertical white sheet will attract a great range of insects which can be picked directly from the sheet when they settle. An ultraviolet light bulb will increase the catch markedly.

Some other instruments that biologists use in the field are illustrated below.



**Figure 1.23**  
A data logger – this is used to record information



**Figure 1.24**  
A pH kit – this is used to measure the pH of soil or water



**Figure 1.25**  
A flow meter – this is used to measure the rate of flow of water



**Figure 1.26** A field microscope – this is used to investigate the structure of specimens in the field, whilst still fresh



**Figure 1.27** A theodolite – this is used to measure the height of trees or of slopes in the area

One recent addition to the tool list of field biologists is the GPS (Global Positioning System) receiver. This equipment makes it possible to record positions quickly and extremely accurately. By taking several readings at different points on the perimeter of the area, an accurate map of the area can be drawn.



**Figure 1.28** A GPS (Global Positioning System) receiver

**Activity 1.12: Types of apparatus**

Make a table that contains three columns. Put a heading for each column as below:

- Apparatus mainly used in the laboratory
- Apparatus mainly used in the field
- Apparatus that can be used in both field and laboratory

Try to list at least five pieces of apparatus in each column

**Review questions**

Choose the correct answer from A to D.

1. It is not true that:
  - A electron microscopes can only be used in the laboratory
  - B some light microscopes can be used in the field
  - C light microscopes give better magnification than electron microscopes
  - D light microscopes were invented before electron microscopes
2. A theodolite is:
  - A an item of laboratory equipment that measures height
  - B an item of field equipment that measures height
  - C an item of field equipment that measures slope
  - D an item of laboratory equipment that measures slope
3. When a biologist centrifuges a suspension, the solids are separated from the liquid in the following way:
  - A The solids float to the top because they are lighter.
  - B The solids are pulled to the bottom because they are heavier.
  - C The solids are pulled to the bottom because they spin faster than the liquids.
  - D The solids float to the top because they spin slower than the liquids.
4. Fieldwork is important in biology because biologists can gather information about:
  - A individual organisms in their natural surroundings
  - B how organisms are distributed in a particular area
  - C how the organisms in an area change over time
  - D all of the above

**Activity 1.13**

It is important to use equipment properly to make sure that your results are reliable and valid. Here are two very useful and very different pieces of equipment for studying biology: a microscope and a quadrat. For each one produce a set of instructions that would help a student using the equipment for the first time to use it correctly. Let a friend look at what you have done – can they follow your instructions correctly?

5. Bacteria are usually cultured in:
  - A test tubes
  - B beakers
  - C Petri dishes
  - D none of these
6. Pitfall traps are used to catch:
  - A flying insects
  - B small ground-dwelling animals
  - C damaged plants
  - D all of these
7. When estimating the numbers of a species in an area, biologists use quadrats that are:
  - A placed at regular intervals along a transect
  - B placed deliberately all over the area
  - C placed at random
  - D placed one after the other along a transect
8. When choosing an item of equipment to measure volume you should mainly consider:
  - A only the total volume to be measured
  - B only the precision to which the instrument can measure
  - C the ease with which you can use it
  - D both A and B
9. The ‘white sheet and bright bulb’ technique used to trap flying insects at night gives:
  - A a good indication of numbers but a poor indication of types found in the area
  - B a good indication of the types found in the area but a poor indication of numbers
  - C a good indication of both types and numbers
  - D a poor indication of both types and numbers
10. Which of the following statements is not true about transect studies of an area?
  - A they give a good indication of how the abundance of different organisms changes across an area
  - B they give a good indication of the overall numbers of an organism in an area
  - C they show the strength of the current flow in a stream
  - D they involve laying out a tape to take direct observations or lay quadrats on

### 1.3 The relevance and promise of biological science

By the end of this section you should be able to:

- Explain how biological science is relevant to food production, health and disease, conservation, and control of the population.
- Explain the promise of biology in relation to genetic engineering and biotechnology.

At the start of this unit we defined biology as ‘the science of life’. This makes it a pretty big subject! Biology seeks to understand how all life functions – including life on other planets, should it exist. Biology attempts to give scientific answers to many questions that most people think are important. Some of these are listed below:

- Where did humans come from?
- Where did I come from?
- How do I work?
- How did all life begin?
- How is disease caused?
- How is AIDS caused?
- How can vaccines be developed against diseases like malaria and AIDS?
- What makes cancer cells different from ordinary cells?
- Will it ever be possible to grow a new kidney just for me?
- Will people one day live forever?
- What causes global warming?
- How can we solve problems of food shortage?

#### Activity 1.14: Library search

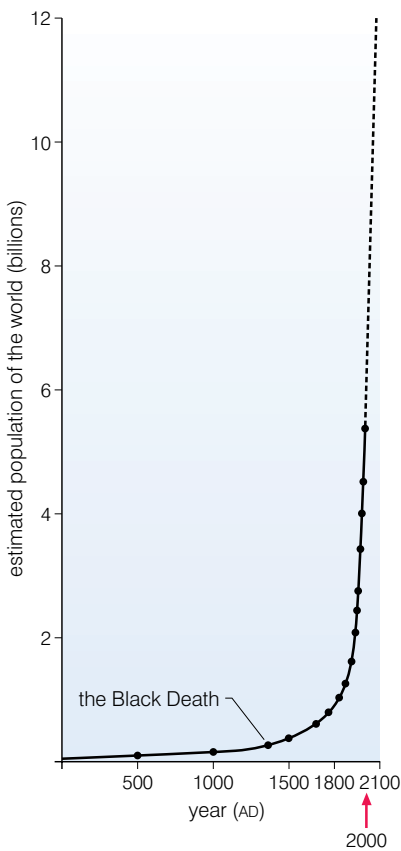
Select five questions that biology attempts to answer. You may choose from the above list, but there are many others. Do some research in a library and, for each, write a few lines (no more) about what biologists say about the topic and whether you accept the biological ‘answer’ or not. Explain why you agree or disagree.

Because biology is the science of life, biologists undertake all kinds of research. Some try to find possible biological explanations for other, non-scientific, aspects of life. Some try to find biological explanations for why some people:

- have a strong religious belief whilst others don't
- are record-breaking athletes, like Haile Gebrselassie and Meseret Defar, and others aren't
- have amazing musical talent, whilst others don't, or
- can write poetry, whilst others can't.

Biologists also try to find out why organisms behave in the way that they do. When this is applied to humans, it is often called 'behavioural psychology', but many consider it to be a branch of biology. Some of these biologists believe that it will one day be possible to understand how all the nerve cells that make up the brain interact with each other to store memories, carry out problem-solving activities and learn as well as modify behaviour patterns.

The study of biology has relevance in almost every aspect of life. It would take far too long to analyse all aspects of the relevance of biology. However, there are some which are undoubtedly of great importance.



**Figure 1.29** How the world population has changed over the past 2000 years

### Biology and agriculture

The world's population is growing at an alarming rate and this poses challenges to governments all over the world. The extra people all need homes, food and all the other services that are provided.

Many biologists are addressing the problem of how to produce the extra food. However, they have another problem to consider, which is that global warming may alter the way in which crops grow. Many crops that now produce high yields in some countries will not do so if the current trends continue. Some countries will benefit, as they will find that their agricultural output will increase with global warming. There are many different estimates as to which countries will 'win' and which will 'lose'.

So how can biologists help? They are carrying out research into how to produce crop plants that:

- will be adapted to the new conditions
- are capable of producing their crop quickly so that more than one crop can be obtained per year from a field
- are disease resistant
- are drought resistant

This work involves the genetic modification of existing crop plants to give them the new characteristics that will enable them to be productive in the changed environment.

## Biology and medicine

Biologists are also able to give advice on ways of reducing the rate of population growth. They can advise individuals and governments on effective methods of contraception and ways of educating people about the need to limit population growth.

Biologists, as we found earlier, are closely involved in medical work. Doctors and nurses have specialised biological knowledge and expertise to help sick people and to advise people on ways of staying healthy. Their work is supported by a whole range of other biologists, such as:

- medical laboratory technicians who test blood samples and other samples and provide reports for doctors
- medical researchers who are constantly finding out more about the ways in which disease-causing organisms function and are spread
- radiographers, who produce X-rays and other images to help in the diagnosis of disease
- specialised researchers who look into why and how cancer is caused
- drug development researchers, who usually work for a commercial company and develop new drugs to treat diseases

These are just a few of the biologists involved in medical work – there are many others.

## Biology and the environment

Biologists are actively involved in monitoring the impact of global warming on the environment. Many of the fieldwork techniques we discussed earlier are used to find out how the abundance and distribution of species in areas are changing. These biologists give advice to governments on how best to conserve environments and to, where necessary, introduce new species that will maintain the best balance of species within the area.

**Biotechnology** is an exciting area of biological research that is expanding rapidly. It involves many different aspects of biology. Some of these can be seen in figure 1.30 on the next page.

### Activity 1.15

Work in groups and brainstorm all the different ways in which biology is important. Produce a spider diagram with the word biology in the middle and show as many links to different areas as possible. Then bring all your ideas together with the rest of the class to produce one big spider diagram which could go on the wall of your classroom.

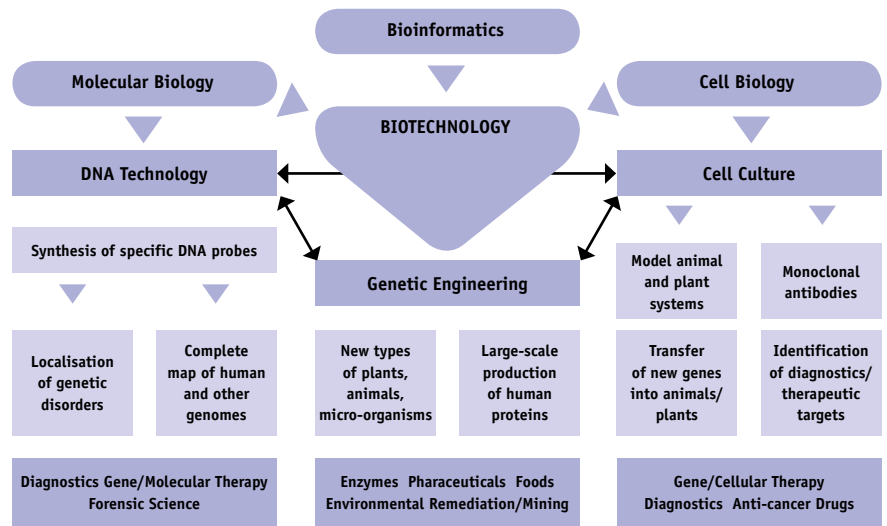


Figure 1.30: A flowchart showing different branches of biotechnology

**KEY WORD**  
**biotechnology** use of micro-organisms and enzymes that will benefit mankind

The promise of research in these fields is huge. Among the goals are:

- cures for genetic diseases
- treatments for degenerative diseases, such as Parkinson’s disease and Alzheimer’s disease
- establishing biologically controlled industrial processes to manufacture more biological products in the same way as insulin is now manufactured
- producing drugs that are ‘tailor-made’ to suit an individual’s needs
- genetically modifying plants to meet a specific need; for example:
  - plants that can produce a good yield of a crop in dry conditions
  - plants that produce their own insecticide will not need to be sprayed with chemical insecticides
- cloning of productive animals and plants
- production of monoclonal antibodies that can deliver a drug to only those cells that need treatment (for example, cancer cells)
- using stem cells to repair damaged organs and, ultimately, to grow whole new organs from just a few of a person’s stem cells

**Biotechnology**

Biotechnology isn’t just new technology. Some biotechnological applications have been around for thousands of years. Using yeast to ferment sugars has been used for centuries in the manufacture of both bread and alcoholic drinks.

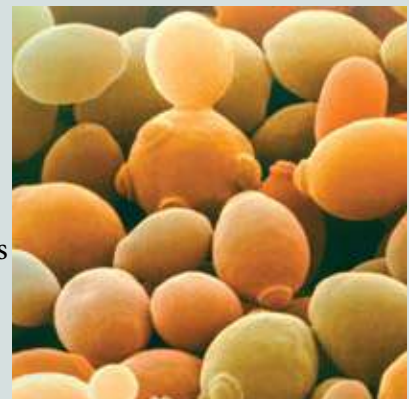


Figure 1.31 Yeast is a unicellular fungus that can ferment sugar to produce alcohol and carbon dioxide.



## The relevance of biology in Ethiopia

Biology is very relevant in Ethiopia considering the issues of overpopulation, food security, environmental well-being, health care, natural resource conservation, biodiversity and others, which the country needs to address. Practical biological knowledge is of special relevance for Ethiopia and education in biology needs special attention.

- As citizens of Ethiopia we must have the biological literacy to understand and assist in the preservation, development and proper use of the abundant biological resources which are our heritage.
- We need to systematically combine the wealth of indigenous knowledge with modern science by training an army of able biologists.
- We need to control land degradation, biodiversity loss, diseases and other problems, as well as to develop the biological and agricultural potential that will contribute positively to transforming our country's economy.

### Activity 1.16: Biotechnology and its relevance in Ethiopia

The list shows just some of the ways in which biotechnology is advancing and will influence our lives. Carry out a library search to investigate the potential of biotechnology. You could expand on some of the suggestions given, but try to include new ideas also. Write a report on your findings and include in your report ways in which biotechnology could help the development of Ethiopia.

## Review questions

Choose the correct answer from A to D.

1. It is true to say that biotechnology is:
  - A a new and rapidly expanding area of biological research
  - B a new but relatively ineffective area of research
  - C an old but rapidly expanding area of biological research
  - D none of the above
2. Biological science is relevant to our lives because it attempts to explain:
  - A the way in which humans function
  - B the place of humans on this planet
  - C the origin of life on this planet
  - D all of the above
3. Biologists are trying to help deal with the problem of a growing population by:
  - A developing crop plants with an increased yield
  - B giving advice on the most effective programmes of contraception
  - C developing crop plants that are resistant to disease
  - D all of the above
4. Fieldwork is important for biologists engaged in environmental protection and conservation because it allows them to:
  - A gather information about how the organisms in an area are changing

- B gather information about how the conditions in the environment are changing
  - C make predictions about future trends in the area
  - D all of the above
5. Which of the following is a current rather than a possible future use of biotechnology?
- A producing tailor-made drugs to suit individual needs
  - B using stem cells to grow a new heart for someone who needs a transplant
  - C monoclonal antibodies used in pregnancy tests and to diagnose diseases
  - D producing cures for genetic diseases

### KEY WORDS

**AIDS** a disease that severely reduces the body's immune functioning

**HIV** the virus that causes AIDS



**Figure 1.32** Opportunistic infections such as pneumocystosis or cancers such as Kaposi's sarcoma can signal the final stage of HIV infection, AIDS.

## 1.4 Biology and HIV/AIDS

By the end of this section you should be able to:

- Explain how biologists are actively involved in the fight against AIDS.
- Describe how you can help community efforts to control AIDS.
- Describe the decisions you will need to take to help control AIDS.

**AIDS** is short for acquired immune deficiency syndrome and is caused by the human immuno deficiency virus (**HIV**). You will learn more about the structure of HIV and how it causes AIDS later. However, you should be aware that HIV infects cells in our immune systems called T-helper cells that enable us to fight off other diseases. For a time, our body keeps replacing the HIV-infected cells, and this can last for many years. However, the body eventually cannot keep pace and AIDS develops. People suffer from 'opportunistic' infections that they would normally have been able to fight off. They also start to develop some forms of cancer that they would not normally develop. AIDS is usually fatal.

The AIDS epidemic is affecting more people than ever before.

There are:

- 33 million people living with AIDS (2.2 million in Ethiopia)
- 2 million children living with AIDS
- 11.6 million AIDS orphans in Africa alone (650 000 in Ethiopia)
- over 17 million women living with AIDS worldwide

If the map of the world was redrawn to show the numbers of people infected by HIV, it would look something like this:



**Figure 1.33** The world would look very different if it was redrawn to show global levels of HIV infection.

AIDS is largely a sexually transmitted disease (STD), although there are four main ways in which HIV can be transmitted. These are:

- homosexual or heterosexual intercourse with an infected person
- transfusion of infected blood or blood products
- sharing infected needles
- from mother to child during pregnancy

In all these cases HIV must cross a barrier and find its way into the blood so that it can infect the T-helper cells and multiply.



### Activity 1.17

The poster in fig 1.34 is not completely accurate. Decide what the main mistake in this message is. Then design and make your own poster to help educate everyone in your community about the ways in which HIV/AIDS is transmitted. This helps people change their behaviour so they can avoid becoming infected.

**Figure 1.34** The ways in which HIV is transmitted from person to person

## How can biology help in the fight against AIDS?

There are several methods of combating the spread of a disease. These are described below.

- Break the transmission pathway – if the disease cannot spread from one person to another, it will eventually disappear.
- Produce drugs that kill the virus or at least stop it from reproducing. Antibiotics act in this way on bacteria, but cannot act on viruses.
- Produce a vaccine against the virus. When vaccines are used, one of the aims is to build up a ‘herd immunity’ to break the transmission pathway. If enough people in an area are immune, the micro-organism causing the disease cannot easily spread to an uninfected person and so the disease is eliminated.

**Activity 1.18 Breaking the transmission pathway – ‘brainstorming’**

AIDS is a sexually transmitted disease and so breaking the transmission pathway must focus on transmission through sexual intercourse. If promiscuous sexual intercourse can be reduced, the rate of transmission of AIDS will reduce with it.

Your teacher will divide the class into groups. Each group will ‘brainstorm’ one of the topics in the list (although there is no reason why you should not think of others as well).

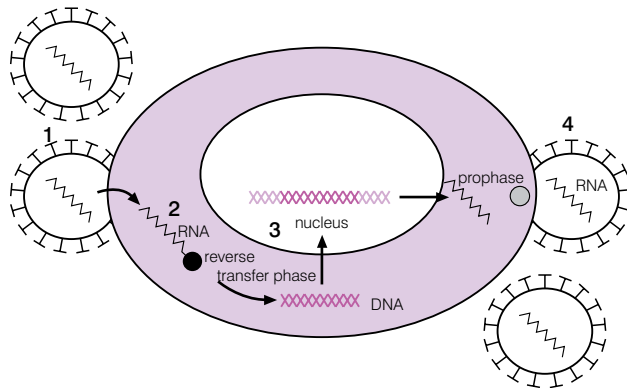
- Reasons why young women (and/or young men) should say 'no' to sexual intercourse before marriage

- Things young women (and/or young men) can do to avoid the temptation to have sexual intercourse
- Things boyfriends and girlfriends can do together without encouraging each other to have sexual intercourse
- Things young people in your community can do to occupy their free time
- Excuses given for not using condoms and responses to them

At the end of the brainstorming session, each group should produce a poster showing how their contribution would help to break the transmission pathway.

HIV and similar viruses are called **retroviruses** and they all have a similar life cycle, shown in the diagram:

- 1 – the entry phase
- 2 – viral genetic material is converted to DNA
- 3 – the new DNA enters the host cell DNA
- 4 – the new DNA ‘instructs’ the cell to make more HIV



**Figure 1.35** Life cycle of a typical retrovirus

**KEY WORDS**

**retrovirus** a virus that inserts its RNA into the host cell where it is ‘reverse transcribed’ to DNA

**anti-retroviral drugs** drugs that target retroviruses and prevent them replicating

**highly active anti-retroviral therapy (HAART)** treatment using a combination of anti-retroviral drugs

Biologists have developed drugs that target and aim to break this life cycle. They are called **anti-retroviral drugs**. There are different anti-retroviral drugs that target different stages in the life cycle. They are more effective when taken in combination than when taken singly, although there can be side effects. The combination treatment is called **highly active anti-retroviral therapy**, or **HAART**. However, it is important to remember that these drugs only treat the HIV that is currently present in the body. They do not provide any lasting immunity and a person could be reinfected.

Other biologists have been working for years to try to produce a vaccine against HIV. A vaccine *would* provide lasting immunity against reinfection by HIV. One of the problems has been that HIV mutates (changes) rapidly and that any one infected person can have several different types of HIV in them. However, researchers

have found a part of the virus that is found in all strains of HIV and is crucial to the virus infecting the cells. They have constructed a vaccine based on this. Their research is also unusual because they have attached this part of HIV to a common cold virus. Previously most experimental AIDS vaccines had been based on a weakened form of HIV itself and were potentially dangerous because the virus could always revert to its infective form.

Also, other biologists are studying a group of people in Kenya who have been repeatedly exposed to HIV but never developed AIDS. Their immune responses to HIV may hold the key to a vaccine. It has been shown that human antibodies produced against HIV completely protect some monkeys against a very similar disease caused by a very similar virus. A vaccine could well be possible.

### What can we do in the fight against AIDS?

There are a number of things that all of us can do. The first is to recognise that people with AIDS are quite simply sick people who need medical care as well as the support and love of their families and friends. AIDS victims have been stigmatised for years in all countries all over the world. This makes the problem worse in a number of ways:

- It makes it harder for victims to come to terms with their illness.
- It may prevent them from seeking early advice for fear of stigmatisation; this in turn may lead to further infection before the condition is diagnosed.
- It can make governments reluctant to take decisive action for fear of offending powerful pressure groups.

We must show tolerance and support. You may one day be in the unenviable position of having to watch someone you love die from a condition that gradually robs them of all ability to look after themselves and turns their body into a shadow of what it was. It could be someone much younger than you, which always seems even worse. People in this position need great strength of character to continue to support the dying person and probably support the rest of the family as well. We need friends to help us through this and we should not forget to help our friends also. The community must pull together: we cannot fight AIDS alone.

You will probably have to make some difficult choices about your personal behaviour. Communities are made up of individuals and although communities can agree a course of action, individuals must then support this course of action.

Although, as individuals, we can do little about the transmission of AIDS through infected blood products or from mother to child, there are things we can do to help control the spread of AIDS by breaking the transmission pathway. These include:

- Restricting the number of sexual partners. In terms of AIDS, this is simple mathematics. If we have sex with many people, we increase our risk of contracting HIV and then passing it on. Sex within a

### Beware fake cures

Unproven AIDS cures have been around since the syndrome emerged in the early 1980s. These cures are a swindle. Someone who invests their savings in a worthless potion or an electrical zapper has less money to spend on real medicines and healthy food.

Here in Ethiopia there are a number of fake cures prescribed by different groups. Beware of such cures. They are often presented as 'the natural way to cure AIDS'. These fake cures often make things worse and at the very least they exploit a vulnerable group of people. If the cure is presented as 'the miracle cure for AIDS' or 100% effective, it is a fake. Also, be wary of someone who won't tell you what's in the cure.

### Activity 1.19 Poet

Choose one of the following situations and write a poem to show how it might have happened or have been avoided:

- a girl who contracts AIDS from her only sexual encounter – a casual encounter which she did not intend; it happened when she was feeling low as a result of an argument with her best friend
  - a boy who finds he has AIDS as a result of sharing needles to inject drugs
  - a girl/boy who has to give up his/her dream of further education to support the family because the father is dying from AIDS
- or you could think of your own AIDS-related situations.

loving, monogamous relationship limits the spread of AIDS. This will require strength of character as friends may not be prepared to restrict the number of their sexual partners. You should not be swayed and you should try to educate them that their choice is a threat to the health and well-being of the whole community.

- Men can elect to be circumcised. This significantly reduces the risk of men acquiring HIV, although it has little effect on them passing on the virus if they do become infected.
- Not sharing infected needles. Drug users who do this are, again, threatening the well-being of the community, as they may spread the virus from one to another and then into other members of the community through intercourse. You should be aware of all the dangers of the drug habit and make an informed choice that considers not just yourself, but others as well.

Remember, community action is always better than individual action. Across Ethiopia, community initiatives and local government are coming together to make a difference in the AIDS response.

During a visit to the country, a United Nations AIDS Executive Director visited some of the programmes and projects putting into action the goals of universal access to HIV prevention, treatment, care and support services.

The government-run local health centres deliver primary health services such as family health, communicable disease prevention and control, including HIV and health education. Being aware of the advice these centres can offer is crucial in the fight against AIDS.

### Activity 1.20 Good friend / bad friend

In this activity, you will be divided into groups of three to devise a short role-play. In each group:

- one person will be the 'uncertain teenager' who is tempted to try a new experience
- one person will be the 'bad friend' who will try to persuade him/her that the experience will be fun with no problems
- one person will be the 'good friend' who will try to persuade him/her that there are always consequences and he/she needs to think carefully

Temptations could include:

- a girl wanting to have sex with a popular

boy who is a good athlete

- boy who has not had sex because he wants to remain AIDS-free being tempted by his girlfriend
  - boy/girl being tempted to use drugs
  - boy planning to have unprotected sex with his girlfriend
  - boy/girl being approached to have sex with someone who has another lover
- but you could think up other topics of your own.

Each group should spend a few minutes discussing the outline of their role-play before presenting it to the class.

## Review questions

Choose the correct answer from A to D.

- The main way that AIDS is transmitted is:
  - from an infected mother to her unborn child
  - by using infected blood products
  - through drug users sharing infected needles
  - through sexual intercourse
- Ways of reducing the transmission of AIDS include:
  - restricting the number of sexual partners a person has
  - male circumcision
  - not sharing infected needles
  - all of the above
- Which of the following is not a reason for developing a vaccine against HIV/AIDS?
  - it would make individual people immune to AIDS
  - it would help to create a 'herd immunity', protecting people who were not immunised for some reason
  - to produce a cure for people already infected with AIDS
  - it would reduce the spread of HIV/AIDS within communities and across the world
- Anti-retroviral drugs are drugs that:
  - give someone immunity against AIDS
  - break the life cycle of HIV within a cell
  - stop the transmission of AIDS from person to person
  - prevent other illnesses from developing in someone with AIDS
- Community action against AIDS is essential because:
  - it can help break the transmission pathway in that community
  - members of the community can support each other
  - it can help reduce the stigma of AIDS
  - all of the above

## Activity 1.21

Work in small groups. Discuss ways in which you can help prevent the spread of HIV/AIDS in your community – and how you can support those people who are already affected by this disease.

Make two lists, one headed **'Preventing the spread of HIV/AIDS'** and the other headed **'Supporting people affected by HIV/AIDS'**.

Then have a session as a whole class. Put the same two titles on the board and each group adds something to the lists in turn until every idea has been used.

## Summary

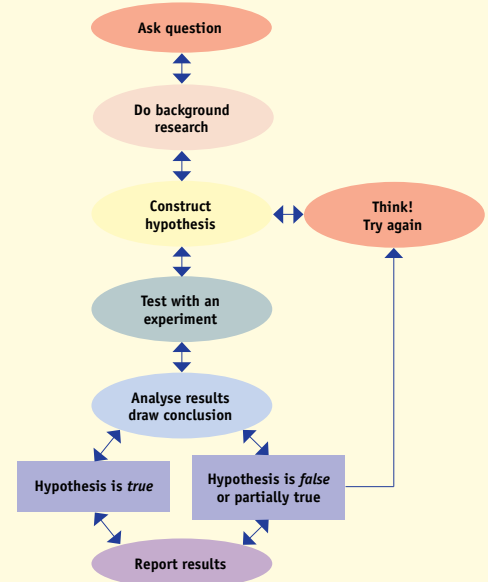
In this unit you have learnt that:

- Biology is the study of life and living organisms; the term biology is derived from the words *bios* (= life) and *logos* (= study).

There are many fields of biology including:

- paleobiology, the study of the origin and evolution of life
- biomedical biology, research into the development of new drugs and vaccines

- astrobiology, the investigation of the possibility of life on other planets
- and many more
- Science is a unique, experimental system of acquiring a scientific knowledge of the scientific method.
- The main steps of the scientific method are:



- Redi and Pasteur carried out controlled experiments that disproved the theory of generation.
- Scientific experiments seek to establish cause and effect.
- Experiments can only establish cause and effect if changes in the IV (independent variable) are shown to cause changes in the DV (dependent variable).
- To show cause and effect a fair test must be carried out in which other factor results are controlled so that their influence can be eliminated.
- Accuracy refers to how precisely a measurement is made.
- Reliability concerns how repeatable the results of an experiment are and how dependable they are.
- Validity concerns whether an experiment really measures what it says it is measuring.
- Scientists report the results of their research in scientific journals such as *Nature* and *Science*. These are read by other scientists working in the same field who can repeat the research and comment on any conclusions that have been drawn.
- Any report must contain:
  - a title, which states clearly what is being investigated
  - a hypothesis, often extended to a prediction for the particular experiment



- a clear description of the experimental procedure
- a full account of the results obtained; it is often helpful to summarise these (where appropriate) in graphs, charts and tables
- the conclusions that have been drawn from the results
- an evaluation of the procedure
- an acknowledgement of the use of any other person's work
- Biologists use specialised equipment; some apparatus is used mainly in the laboratory, such as:
  - microscopes
  - centrifuges
  - Petri dishes
  - measuring cylinders
  - balances
- Other apparatus is used mainly in the field, such as:
  - quadrats
  - plant presses
  - theodolites
  - GPS receivers
  - flow meters
- Biological research is highly relevant to us all because it includes research into:
  - producing new crops that will help to feed an increasing world population
  - producing new vaccines including, one day, a vaccine against AIDS
  - producing new drugs that are more effective in treating diseases
  - the environment which will help us to maintain key habitats to prevent species from becoming extinct
  - genetic engineering which will offer ways of treating genetic diseases as well as helping to produce genetically engineered crops with a higher yield
- Acquired Immune Deficiency Syndrome (AIDS) is caused by the Human Immunodeficiency Virus (HIV).
- Africa has the highest incidence of AIDS anywhere in the world.
- HIV can be transmitted by:
  - sexual intercourse

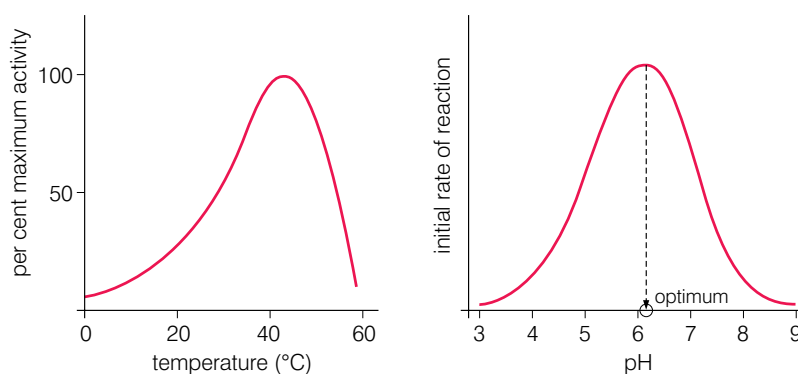
### Activity 1.22

Using the ideas you developed as a class in activity 1.21, divide into groups again and produce a classroom display based on **'Preventing the spread of HIV/AIDS'** and **'Supporting people affected by HIV/AIDS'**. This display can then be used in your classroom or in the school entrance to inform and support anyone who visits, works or studies in your school.

- transfusion of infected blood
- drug users sharing infected needles
- from mother to child during pregnancy
- HIV is a retrovirus and is treated by anti-retroviral drugs.
- HAART (Highly Active Anti-Retroviral Therapy) is a combination of anti-retroviral drugs each targeted at a different phase of the HIV life cycle.
- To reduce the spread of AIDS, we should:
  - restrict the number of sexual partners
  - not share infected needles
  - encourage men to be circumcised

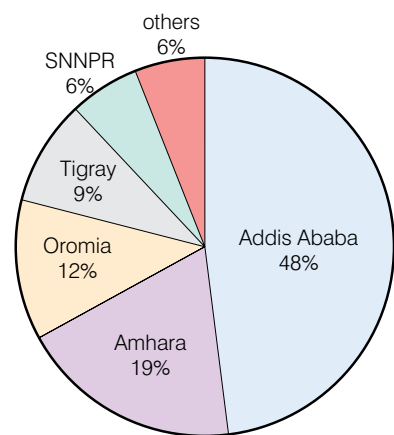
### End of unit questions

1. List the main steps of the 'scientific method'. For each step, explain what is involved.
2. a) In a scientific experiment, what is:
  - (i) the independent variable (IV)?
  - (ii) the dependent variable (DV)?
 b) Why is it important to control all other variables?  
 c) What is a control experiment?
3. Explain what is meant by the following terms in a scientific experiment:  
 accuracy reliability validity
4. The graphs show the results from two experiments into how fast an enzyme works at different temperatures and at different pHs.



- a) Describe the results obtained for:
  - (i) temperature
  - (ii) pH
- b) What would be the ideal conditions for this reaction?  
 Explain your answer.

5. For each of the following pieces of equipment:
- say whether you would use it mainly in the field or mainly in the laboratory
  - say how you would use the equipment
    - optical microscope
    - quadrat
    - theodolite
    - electronic balance
    - pipette
    - Petri dish
    - plant press
6. Describe *three* decisions that individuals can take about their lifestyle to help to limit the spread of AIDS.
7. Anti-retroviral treatment (ART) involves the use of anti-retroviral drugs to treat AIDS. The pie chart shows the proportion of all people receiving ART in different regions of Ethiopia (data collected in 2005).
- Briefly explain how anti-retroviral drugs work.
  - Use the chart to:
    - describe the distribution of ART in Ethiopia
    - suggest reasons for that distribution.
8. Read the case study below of Alexander Fleming's discovery of penicillin.

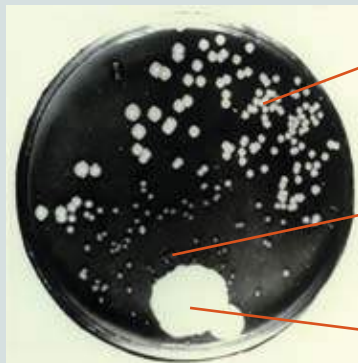


In 1928, Alexander Fleming was culturing some bacteria. He left a culture plate smeared with bacteria on his lab bench while he went on a 2-week holiday. When he returned, he noticed a clear region surrounding the growth of a mould that had accidentally contaminated the plate.

Unknown to him, a spore of a rare fungus called *Penicillium notatum* had drifted in from another lab one floor below.

Seeing that clear region led Fleming to correctly deduce that the mould must have released a chemical that inhibited the growth of the bacteria.

Fleming's deduction became his hypothesis for future experiments. He hypothesised that '*Penicillium notatum* (the mould) releases a chemical that inhibits the growth of bacteria.'



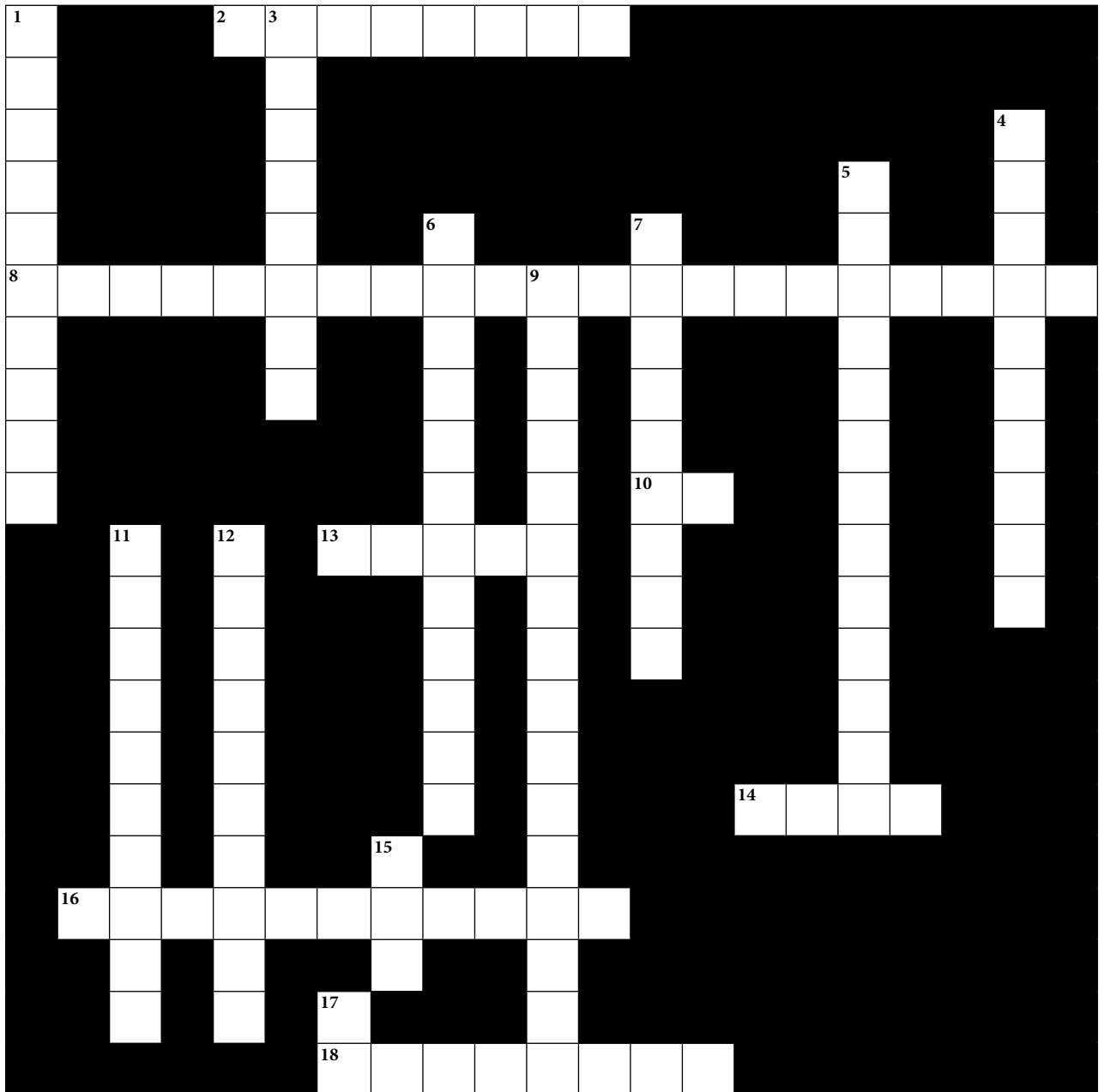
bacteria growing

no bacteria growing in the region around the mould

mould

How do you suppose he tested this hypothesis using the scientific method? (*Hint: look back at the way in which Pasteur used the scientific method.*)

Copy the crossword puzzle below into your exercise book (or your teacher may give you a photocopy) and solve the numbered clues to complete it.



**Across**

- 2. An experiment in which extraneous variables have been controlled (4, 4)
- 8. The idea that living things can arise from non-living matter (11, 10)
- 10. An experimenter measures changes in this variable as the IV changes (2)
- 13. Highly active anti-retroviral therapy (acronym) (5)
- 14. The condition resulting from infection by HIV (4)

16. How consistent the results are from repeats of an experiment (11)
18. The extent to which an experiment measures what it says it is measuring (8)

**Down**

1. A piece of equipment for viewing small objects (10)
3. The precision with which we measure something (8)
4. A statement of the predicted effect of the IV on the DV in an experiment (10)
5. He performed an experiment to show that the spontaneous generation of flies from rotten meat could not happen (9, 4)
6. The French scientist who finally proved that spontaneous generation is not possible (5, 7)
7. A dish often used for culturing bacteria (5, 4)
9. The process scientists use in their investigations (10, 6)
11. A type of investigation that tries to establish cause and effect (10)
12. An 'educated guess' about the likely outcome of an experiment (10)
15. The virus that causes AIDS (3)
17. The variable in an experiment that the experimenter changes (2)

Contents	
Section	Learning competencies
2.1 Inorganic and organic molecules (page 42)	<ul style="list-style-type: none"><li>• Group biochemical molecules as inorganic and organic.</li><li>• Explain which chemical elements are found most often in biological molecules.</li><li>• Describe the properties of water.</li><li>• Explain the importance of water to living organisms.</li></ul>
2.2 Organic molecules (page 52)	<ul style="list-style-type: none"><li>• List and describe the structures of organic molecules in living things and state their functions.</li><li>• Show the structures and functions of biological molecules using chemical formulae and examples.</li><li>• Identify biologically important compounds by conducting simple food tests.</li><li>• Appreciate how biological molecules are obtained from different foods.</li></ul>

### 2.1 Inorganic and organic molecules

By the end of this section you should be able to:

- Group biochemical molecules as inorganic and organic.
- Explain which chemical elements are found most often in biochemical molecules.
- Describe the properties of water.
- Explain the importance of water to living organisms.

## Classification of inorganic and organic molecules

Biological molecules can be classified into two main types:

- inorganic molecules
- organic molecules

So, what is the difference between the two? Look at the formulae of the molecules in table 2.1.

**Table 2.1** Examples of inorganic and organic molecules

Some inorganic molecules	Some organic molecules
Calcium carbonate $\text{CaCO}_3$	Glucose $\text{C}_6\text{H}_{12}\text{O}_6$
Carbon dioxide $\text{CO}_2$	Glycine (an amino acid) $\text{C}_2\text{H}_5\text{NO}_2$
Water $\text{H}_2\text{O}$	Linoleic acid (a fatty acid) $\text{C}_{18}\text{H}_{32}\text{O}_2$
Iron III oxide $\text{Fe}_3\text{O}_4$	Methane $\text{CH}_4$

Can you see that the organic molecules always contain both carbon and hydrogen? Inorganic molecules may contain one or the other (or neither), but not both.

Different organic molecules contain different combinations of carbon and hydrogen. They may also contain other chemical elements. Most biological organic molecules contain oxygen in addition to carbon and hydrogen and some also contain nitrogen.

## Which chemical elements are found most frequently in living organisms?

Look at the periodic table below. This has all the chemical **elements** arranged in such a way that similar elements are placed in the same column – or group.

The elements that are highlighted are the ones that are used to build nearly all biological molecules. What do you notice about their position in the periodic table? Can you find out the importance of this?

Very few other elements are used to build biological molecules, although other elements do have specific functions in biological systems. Some elements that are important for humans are calcium (Ca) for bones, teeth and muscles, chlorine (Cl) for digesting food, fluorine (F) for tooth enamel and iron (Fe) to help blood carry oxygen around the body.

## Activity 2.1: Grouping molecules

Make a table like table 2.1. Place the following substances in the correct columns.

$\text{C}_{12}\text{H}_{22}\text{O}_{11}$  (sucrose)

CO (carbon monoxide)

$\text{C}_5\text{H}_{10}\text{O}_4$  (deoxyribose)

$\text{C}_{18}\text{H}_{36}\text{O}_2$  (stearic acid – a fatty acid)

$\text{NO}_2$  (nitrogen dioxide)

$\text{H}_2\text{SO}_4$  (sulphuric acid)

$\text{C}_3\text{H}_6\text{O}_3$  (lactic acid)

$\text{C}_6\text{H}_{14}\text{N}_2\text{O}_2$  (lysine – an amino acid)

$\text{C}_{10}\text{H}_{16}\text{N}_5\text{O}_{13}\text{P}_3$  (ATP)

NaCl (sodium chloride)

## KEY WORD

**element** a substance that is made of only one kind of atom

Figure 2.1 The periodic table

1																	2
H																	He
3	4											5	6	7	8	9	10
Li	Be											B	C	N	O	F	Ne
11	12											13	14	15	16	17	18
Na	Mg											Al	Si	P	S	Cl	Ar
19	20	21	22	23	24	25	26	27	28	29	30	31	32	33	34	35	36
K	Ca	Sc	Ti	V	Cr	Mn	Fe	Co	Ni	Cu	Zn	Ga	Ge	As	Se	Br	Kr
37	38	39	40	41	42	43	44	45	46	47	48	49	50	51	52	53	54
Rb	Sr	Y	Zr	Nb	Mo	Tc	Ru	Rh	Pd	Ag	Cd	In	Sn	Sb	Te	I	Xe
55	56	57	72	73	74	75	76	77	78	79	80	81	82	83	84	85	86
Cs	Ba	La	Hf	Ta	W	Re	Os	Ir	Pt	Au	Hg	Tl	Pb	Bi	Po	At	Rn
87	88	89	104	105	106	107	108	109	110	111	112	113	114	115	116		118
Fr	Ra	Ac	Rf	Db	Sg	Bh	Hs	Mt	Ds	Rg	Uub	Uut	Uuq	Uup	Uuh		Uuo
			58	59	60	61	62	63	64	65	66	67	68	69	70	71	
			Ce	Pr	Nd	Pm	Sm	Eu	Gd	Tb	Dy	Ho	Er	Tm	Yb	Lu	
			90	91	92	93	94	95	96	97	98	99	100	101	102	103	
			Th	Pa	U	Np	Pu	Am	Cm	Bk	Cf	Es	Fm	Md	No	Lr	

The most common elements in many cells are:

Hydrogen (H) 59%

Oxygen (O) 24%

Carbon (C) 11%

Nitrogen (N) 4%

Others (such as phosphorus (P) and sulphur (S)) 2% combined

(The percentages given are averages for many different cells.)

### Activity 2.2: Library search

See if you can find out:

- the functions of sodium (Na), potassium (K) and phosphorus (P) in humans
- how chlorine helps us to digest our food

**Atoms** of elements can join together to form molecules. We call this forming a chemical **bond**. Sometimes two atoms of the same element join together to form a **molecule** of that element – for example, we breathe in oxygen molecules, each made of two oxygen atoms. This is why the formula for oxygen gas is  $O_2$ . Atoms of one element can join with atoms of another element to make a molecule of a **compound**. The atoms are always present in the same ratio in all the molecules of the compound.

Each atom can make a certain number of bonds with other atoms; this is called its **valency**. See table 2.2 below.

**Table 2.2** The number of bonds (valencies) of atoms of the elements most commonly used to build biological molecules.

Element	Number of bonds formed (valency)
Carbon (C)	4
Hydrogen (H)	1
Oxygen (O)	2
Nitrogen (N)	3
Sulphur (S)	2 (sometimes 4 or 6)
Phosphorus (P)	5

So, whilst a carbon atom can bond with four hydrogen atoms, each hydrogen atom can only bond with one carbon. Because carbon

### KEY WORDS

**atoms** the smallest particles of a chemical element

**bond** the energy that joins atoms together to form a molecule

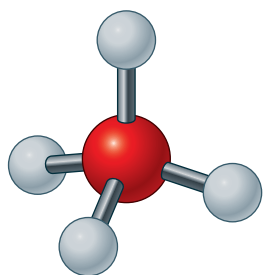
**molecule** a number of atoms bonded together

**compound** a substance made from molecules containing more than one kind of atom in a fixed ratio

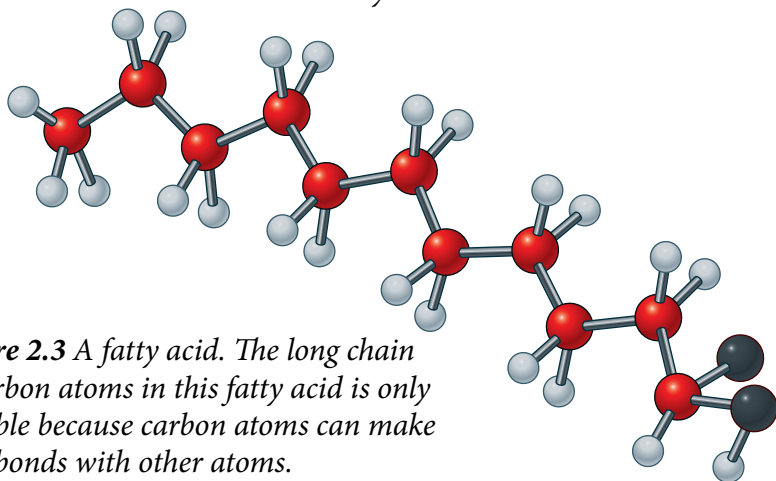
**valency** the number of bonds an atom can make with other atoms



can bond with four other atoms, it can make large molecules with chains of carbon atoms. These are the organic molecules that are the basis of life.



**Figure 2.2** The structure of methane. In a molecule of methane, a carbon atom bonds with four hydrogen atoms. Each hydrogen atom only bonds with one carbon atom.



**Figure 2.3** A fatty acid. The long chain of carbon atoms in this fatty acid is only possible because carbon atoms can make four bonds with other atoms.

### Water, water everywhere?

Well, not quite everywhere. Water covers three-quarters of the planet and on the remaining one-quarter, which is land, water is often not very far away. It may be in streams, rivers, ponds, lakes or in huge underground aquifers.

And, of course, it is in all living things. Most cells are about 70% water and some are as high as 90%.

### What is water?

Just about everyone knows the chemical formula for water –  $\text{H}_2\text{O}$ . Water is made of molecules, each of which contains two hydrogen atoms bonded to one oxygen atom.

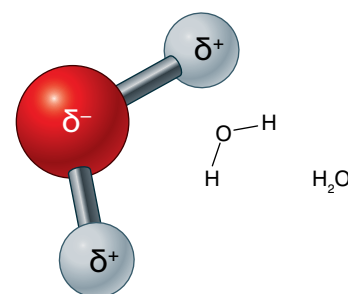
Notice that the molecule is not 'straight' it is bent into a 'v' shape. Also, the molecule forms what we call a 'dipole'. Part of the molecule has a slight negative charge ( $\delta^-$ ) and other parts have a slight positive charge ( $\delta^+$ ).

What is less well known is that in a mass of water (such as the water in a glass or the water in a pond), all the water molecules are interlinked! Besides the bonds joining the hydrogen atoms to the oxygen atom, there are very weak bonds – called **hydrogen bonds** – that join the oxygen in one water molecule (the slightly negative part) to the hydrogen in another water molecule (the slightly positive part).



**Figure 2.4** Water covers three-quarters of the Earth's surface.

Water is the name of a substance. It is the only substance that exists in three states – solid, liquid and gas – at temperatures commonly found on Earth. Solid water is ice, liquid water we call water and gaseous water is steam.



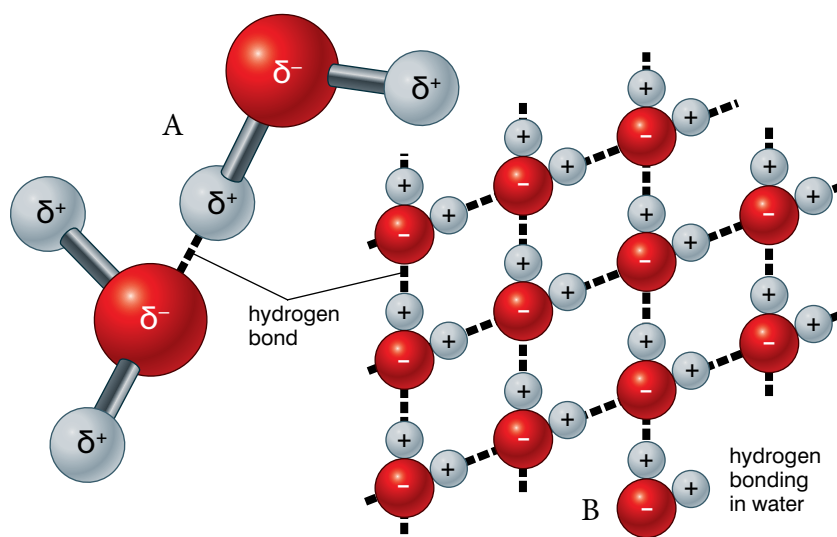
**Figure 2.5** A molecule of water

**KEY WORD**

**hydrogen bonds** *bonds that join the oxygen in one water molecule to the hydrogen in another*

**Figure 2.6** Hydrogen bonding in water.

A Two water molecules hydrogen-bonded together  
B Many water molecules hydrogen-bonded together



The hydrogen bonds in water keep breaking and reforming as the molecules move around, but there is always some bonding between the molecules in a mass of water.

**DID YOU KNOW?**

Hydrogen bonds are found in many biological molecules. Hydrogen bonds hold the two strands of a DNA molecule together and help to hold protein molecules in shape.

**Why is water so important to living things?**

The very first cells on Earth evolved in water about 3.5 billion years ago. Water has many properties that make it important to living things in a number of ways, such as:

- a place to live
- a transport medium
- a reactant in many chemical reactions
- a place for other reactions to take place
- water is a vital chemical constituent of living cells

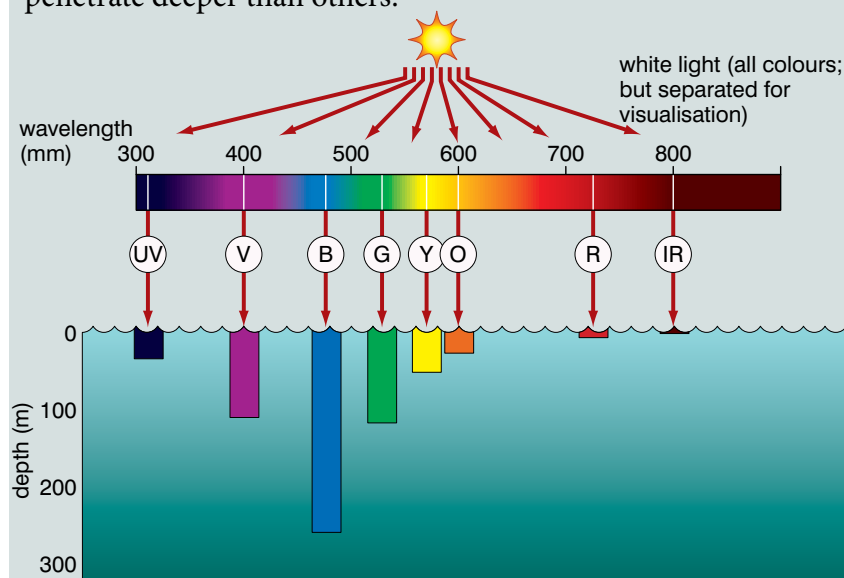
**Water is a place to live in.** Many organisms live in water. Plants and algae both live in water as do many different types of animals



**Figure 2.7** Kelp are giant seaweeds that form 'kelp forests' in which many animals live.

**Water is transparent.** This means that light can pass through the water and allow the plants and algae to photosynthesise. It also means that animals can see where they are going. However, water does not allow all light to pass through it and as we go deeper and deeper, less and less light penetrates.

Different wavelengths of light penetrate to different depths. Red and indigo wavelengths are soon lost. Blue and green wavelengths penetrate deeper than others.



**Figure 2.8** Penetration of different wavelengths of light

**Water has a high specific heat capacity.** This means that it takes quite a lot of energy to heat water up. Water also loses heat quite slowly. This has the overall effect that water stays more or less the same temperature – particularly large masses of water, such as oceans and lakes. This is important as the functioning of enzymes in living cells is affected by temperature. Too hot or too cold and the enzymes do not function efficiently and the reactions in the cells controlled by the enzymes are not carried out efficiently.

**Ice is less dense than liquid water.** It is unusual for the solid form of a substance to float on the liquid form of the same substance, but ice floats on water. This is because water expands when it freezes. So, in cold weather, water freezes from the top down. The ice on the surface then acts as an insulator and slows down the heat loss from the liquid water underneath. So life can continue in relatively warm water underneath the ice all through the cold weather.

**Water has a high latent heat of vaporisation.** This means that it takes a lot of energy to turn liquid water into water vapour (or steam). In turn this means that water doesn't vaporise too easily and that ponds don't dry up too quickly in hot weather – and the organisms in the pond have a better chance of survival. This property is also important in temperature control.

When we sweat, the energy needed to vaporise the sweat comes from our bodies. This heat is then lost from our bodies and so we cool down. If water vaporised easily, sweating wouldn't be as effective in controlling our body temperature.

### KEY WORDS

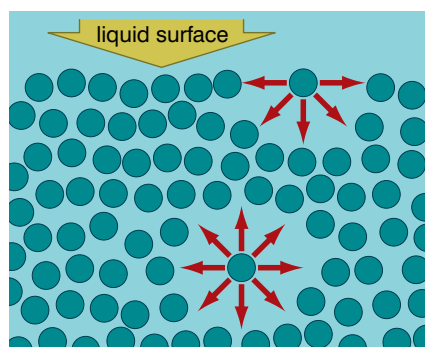
**specific heat capacity** *the amount of energy needed to raise the temperature of 1 g of a substance by 1 °C*

**density** *the mass in kg of 1 dm<sup>3</sup> of a substance (or the mass in g of 1 cm<sup>3</sup> of a substance)*

**latent heat of vaporisation** *the energy used in converting a liquid to a gas at the same temperature*

### DID YOU KNOW?

Water has the highest latent heat of vaporisation of all substances.



**Figure 2.9** The surface tension of water

**Water has a high surface tension.** The water molecules in the main body of a mass of water are hydrogen-bonded to other water molecules on all sides. But at the surface, there is no hydrogen bonding above. So the 'pull' from the sides is stronger than it would otherwise be and the molecules at the surface are held together more strongly.

This is why some animals can 'walk on water' and why others can attach themselves to the surface of the water and live just below the surface. The water strider in figure 2.10 is just one example of an insect that is so light that the force of the surface tension of the water can support the weight of the insect.



**Figure 2.10** A water strider walking on water



**Figure 2.11** Mosquito larvae

The mosquito larvae in figure 2.11 hang from the surface of the water by their breathing tubes. The surface tension is sufficiently strong to hold their weight.

Water is a good solvent for many substances. Many organic and inorganic substances important to life dissolve in water, but don't dissolve either at all or as well in other liquids. Water is very versatile. Because these substances dissolve in water, they can be transported in a water-based transport medium. Biological mechanisms such as active transport, diffusion and facilitated diffusion move the substances into and out of the water (in the transport medium). In mammals, the plasma of blood is 90% water. This is forced through the system of veins, arteries and capillaries by the heart. In plants, water carries dissolved minerals upwards from the roots to other parts of the plants in the xylem vessels. Water in the phloem tubes carries dissolved organic substances all over the plant.

Water has the ideal viscosity for a transport medium. Viscosity is a measure of how fluid a liquid is – how easily it flows. If water were more viscous (less fluid) than it is – think of tar! – then the heart would not be able to move it through the blood vessels. Also, the water inside cells transports substances around the cell; if it were more viscous, it would damage the delicate organelles in the cells. If water were less viscous (more fluid) than it is, it would flow too easily and, inside cells, the organelles would not be supported. Similarly, in the circulatory system, a less viscous liquid would not move the blood cells around the system as efficiently.

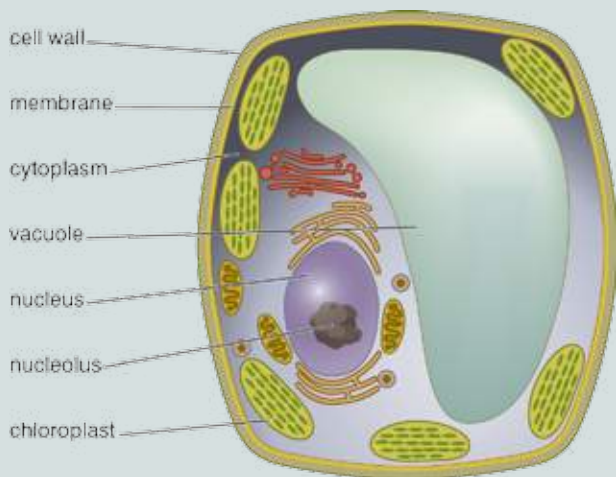
#### DID YOU KNOW?

Water dissolves more substances and in greater quantities than any other liquid.

#### KEY WORD

**surface tension** the tension at the surface of a liquid resulting from unbalanced forces acting on the molecules at the surface

**Water and support in cells**



When plant cells absorb a lot of water, they swell until their cellulose cell wall won't let them swell any more. In this condition, we say they are turgid. Turgid cells press against each other and this pressure helps to support the plant. If the cells lose water, the pressure decreases and so does the support.

**Figure 2.12** A turgid plant cell



**Figure 2.13**  
A A well-watered coleus plant

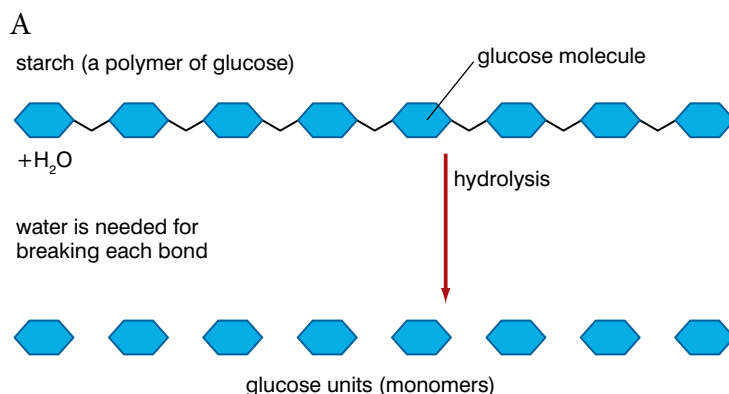


B A coleus plant that has not been well-watered

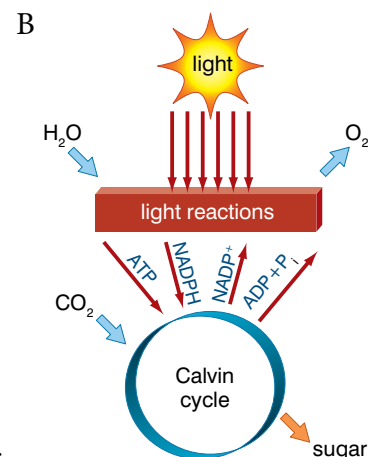
**Water as a reactant.** Many reactions in living things need water as a raw material. Photosynthesis – the process which begins the process of energy transfer between living things – requires water as one of its reactants. No water, no photosynthesis. Water is also involved in digesting large food molecules into smaller ones. Reactions that use water to split large molecules are called **hydrolysis** reactions. *Hydro* = water; *lysis* = splitting. Water molecules are used to split large food molecules into smaller ones that can be absorbed into the bloodstream.

**KEY WORDS**

**reactant** a substance that takes part in a chemical reaction  
**hydrolysis** using water to split large molecules



**Figure 2.14** A The hydrolysis of starch B A summary of photosynthesis



### Activity 2.3: Library search

See if you can find out:

- why gas exchange surfaces, like the alveoli in our lungs, are always moist
- the importance of water in excretion

Water is also involved in other reactions. For example, it is involved in reactions with carbon dioxide in red blood cells that are important in the transport of carbon dioxide around the body as hydrogen carbonate ions.

**Water as a medium for chemical reactions.** Cells function because of the many chemical reactions that are continually taking place in them. Many of these take place on the membrane systems of the cell, but others take place in the liquid 'cytosol' of the cytoplasm. Also, many of the reactions of photosynthesis and respiration take place in the liquid inner regions of chloroplasts and mitochondria. Water is an ideal medium for these reactions – for some of the reasons already discussed:

- It can dissolve many substances – the reactions will only take place effectively in solution.
- It has a low viscosity – the particles can move around and come easily into contact with each other.

So, we can see that, without water, life as we know it could not possibly exist. Water is just too important.

### Review questions

Choose the correct answer from A to D.

- Organic molecules always contain:
  - carbon
  - carbon and oxygen
  - carbon and hydrogen
  - oxygen and hydrogen
- Which of the following groups of substances are all inorganic?
  - water, sugar, calcium carbonate
  - water, calcium carbonate, carbon dioxide
  - carbon dioxide, amino acid, fatty acid
  - sugar, fatty acid, amino acid
- Which of the following statements about atoms and molecules is correct?

Option	Atoms	Molecules
A	The simplest particle of an element	Always contain more than one type of atom
B	Combine to form molecules	Always contain just one type of atom
C	The simplest particle of an element	Always contain more than one atom
D	Combine to form particles	Always contain more than one type of atom

4. The six most common elements in living things are:
  - A carbon, hydrogen, oxygen, nitrogen, potassium and sulphur
  - B carbon, phosphorus, hydrogen, oxygen, potassium and calcium
  - C carbon, calcium, hydrogen, oxygen, nitrogen and phosphorus
  - D carbon, hydrogen, oxygen, nitrogen, phosphorus and sulphur
5. Water molecules can form hydrogen bonds with other water molecules because:
  - A the water molecule contains hydrogen and oxygen
  - B part of the molecule is slightly negative
  - C part of the molecule is slightly positive
  - D all of the above
6. Water has a high specific heat capacity. This means that it:
  - A heats up and cools down slowly
  - B heats up slowly but cools down quickly
  - C heats up quickly but cools down slowly
  - D heats up and cools down quickly
7. Photosynthesis is impossible at a depth of 1000 m because:
  - A it is too hot
  - B only blue light penetrates this far
  - C no light penetrates this far
  - D it is too cold
8. Which of the following is not true about the viscosity of water?
  - A if it were more viscous the heart would not be able to move the blood through the blood vessels
  - B if it were less viscous the organelles would not be suspended in the cytoplasm
  - C if it were less viscous the heart would not be able to move blood through the blood vessels
  - D if it were more viscous the organelles would be damaged in the cytoplasm
9. The high surface tension of water is due to:
  - A unbalanced hydrogen bonding in the body of the water
  - B balanced hydrogen bonding in the body of the water
  - C balanced hydrogen bonding at the surface of the water
  - D unbalanced hydrogen bonding at the surface of the water
10. One benefit of ice being less dense than water is:
  - A water freezes from the top down and water is insulated under the ice
  - B water freezes from the top down and the water under the ice is cooled more quickly
  - C water freezes from the bottom up and the remaining water cools more slowly
  - D water freezes from the bottom up and the remaining water cools more quickly

**Activity 2.4**

Make a wall chart summarising why water is so important for living organisms.

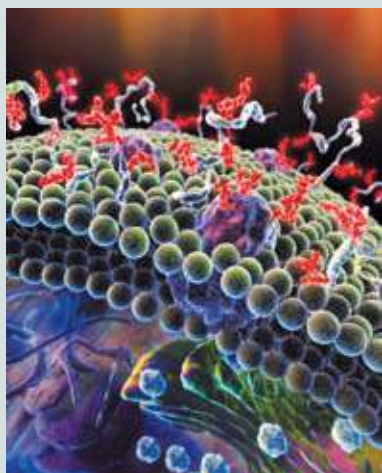
## KEY WORDS

**carbohydrate** *molecule that contains the elements carbon, hydrogen and oxygen*

**starch** *a complex carbohydrate that stores chemical energy in plants*

**glycogen** *a complex carbohydrate that stores chemical energy in animals*

In plasma membranes, carbohydrates are found combined with proteins to form glycoproteins. Glycoproteins often act as antigens – markers for the immune system. The immune system can differentiate between ‘self’ antigens (those that are normally found in the body) and foreign or ‘non-self’ antigens. The presence of ‘non-self’ antigens stimulates an immune response.



**Figure 2.15** A glycoprotein in a membrane

## 2.2 Organic molecules

By the end of this section you should be able to:

- List and describe the structures of organic molecules in living things and state their functions.
- Show the structures and functions of biological molecules using chemical formulae and examples.
- Identify biologically important compounds by conducting simple food tests.
- Appreciate how biological molecules are obtained from different foods.

## What are carbohydrates and why do we need them?

All **carbohydrates** contain the elements carbon, hydrogen and oxygen. The hydrogen and oxygen atoms in a carbohydrate molecule are present in the ratio of two hydrogen atoms to one oxygen atom (for example, glucose,  $C_6H_{12}O_6$ , and maltose,  $C_{12}H_{22}O_{11}$ ). Carbohydrates range from very small molecules containing only 12 atoms, to very large molecules containing thousands of atoms.

Carbohydrates have a range of functions:

- They are used to release energy in respiration – glucose is the main respiratory substrate of most organisms.
- Carbohydrates are a convenient form in which to store chemical energy; storage carbohydrates include:
  - **starch** in plants
  - **glycogen** in animals
- Some carbohydrates are used to build structures; structural carbohydrates include:
  - cellulose, which is the main constituent of the primary cell wall of plants
  - chitin, which occurs in the cell walls of fungi and in the exoskeletons of insects
  - peptidoglycan, which occurs in bacterial cell walls

## What different types of carbohydrates are there?

**Monosaccharides** are the simplest carbohydrates. A monosaccharide molecule can be thought of as a single sugar unit. Other, more complex, carbohydrates have two or more monosaccharide units joined together.

Monosaccharides can be classified according to how many carbon atoms are present in the molecule.

- A **triose** monosaccharide has three carbon atoms – formula  $C_3H_6O_3$ . Glycerate phosphate is a triose important in photosynthesis.



- A **pentose** monosaccharide has five carbon atoms – formula  $C_5H_{10}O_5$ . Ribose is found in RNA nucleotides.
- A **hexose** monosaccharide has six carbon atoms – formula  $C_6H_{12}O_6$ . Glucose is the hexose produced in photosynthesis and used in respiration.

There are several different trioses, pentoses and hexoses. Each triose has the same number of each kind of atom (hence the formula  $C_3H_6O_3$ ), but the atoms are put together in a different way. They are **isomers** of each other. The same is true for the pentoses and hexoses.

Monosaccharides can be classified in a different way – according to the **functional group** that they possess.

There are two functional groups in monosaccharides:

- the aldehyde group with the formula CHO (monosaccharides with this group are **aldoses**), and
- the ketone group, with the formula  $C=O$  (monosaccharides with this group are **ketoses**).

The main significance of this difference is the ability to polymerise. Nearly all the polysaccharides found in living things are polymers of aldose monosaccharides.

Figure 2.16 shows examples of each type of sugar according to both classifications.

### KEY WORDS

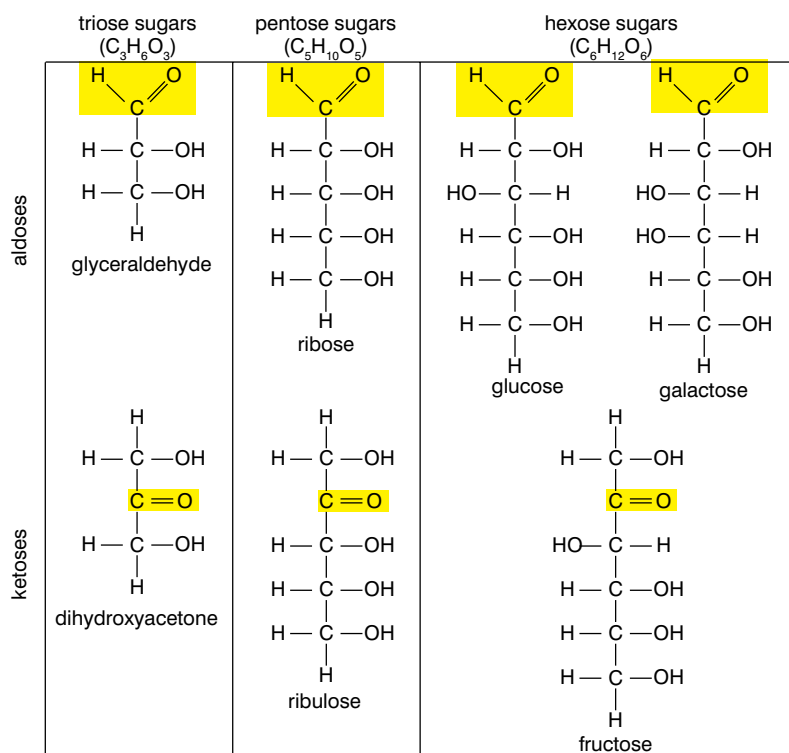
**monosaccharide** a single sugar

**isomers** molecules with the same chemical composition, but a different arrangement of atoms

**functional group** a group of atoms within a molecule that behaves in a particular way

**aldoses** monosaccharides with an aldehyde group in the molecule

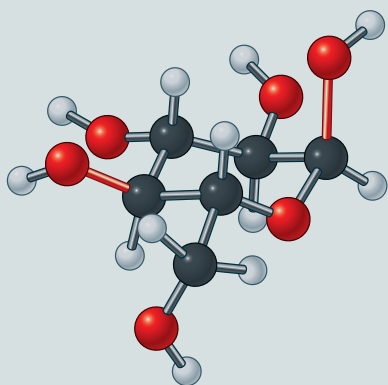
**ketoses** monosaccharides with a ketone group in the molecule



**Figure 2.16** Aldose and ketose monosaccharides

The structures of the monosaccharides above are shown in a 'straight chain' form. However, in solution, they often change into a 'ring' structure. Figure 2.17 overleaf shows the straight chain and ring forms of two hexose monosaccharides – glucose and fructose.

It is easy to think that all the atoms of ring molecules lie in the same plane, but this is not so. Figure 2.18 shows a three-dimensional representation of the atoms in  $\alpha$ -glucose.



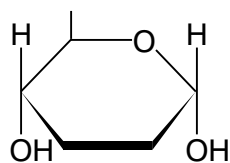
**Figure 2.18** A 3-D representation of the  $\alpha$ -glucose molecule

### KEY WORDS

**disaccharide** a sugar formed when two monosaccharides join together

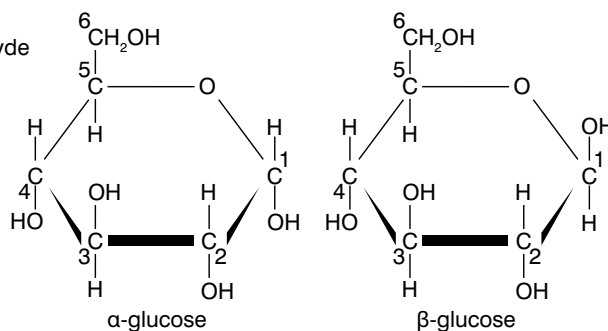
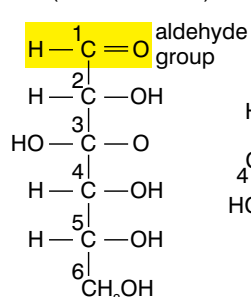
**maltose** a disaccharide derived from two  $\alpha$ -glucose molecules

**sucrose** a disaccharide derived from an  $\alpha$ -glucose molecule and a fructose molecule



**Figure 2.19** A simplified representation of the structure of  $\alpha$ -glucose

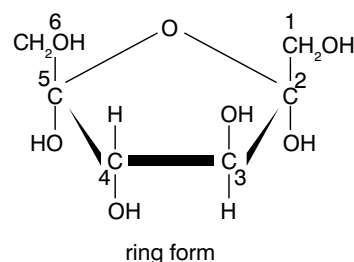
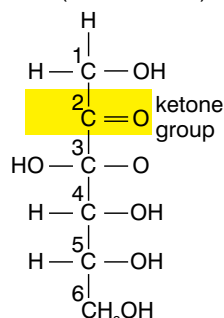
glucose (an aldohexose)



straight-chain form

ring forms

fructose (a ketohexose)



**Figure 2.17** Straight chain forms and ring forms of glucose and fructose

The straight chain form of glucose can produce two different ring forms –  $\alpha$ -glucose and  $\beta$ -glucose. There is only one difference between these two. Can you see it?

The straight chain form of fructose produces only one ring form.

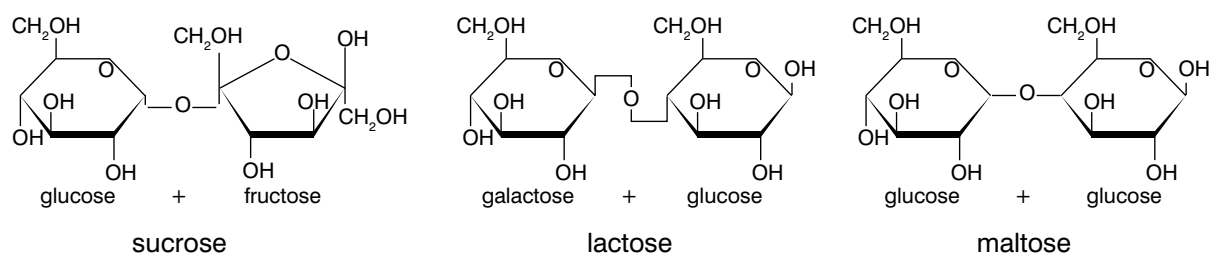
In these structural diagrams, the carbon atoms in the molecules are numbered according to their positions in the molecule.

You do not have to know the position of every carbon, hydrogen and oxygen atom in these molecules. However, if you can remember the simplified structures shown in figure 2.19 this will help you to understand how more complex carbohydrates are formed. These simplified diagrams show the overall shape of the molecule, the position of each carbon atom and the hydrogen and oxygen atoms attached to carbon atoms 1 and 4.

**Disaccharide** carbohydrate molecules are made by two monosaccharide molecules joining together. For example, a molecule of:

- **maltose** is derived from two  $\alpha$ -glucose molecules
- **sucrose** is derived from an  $\alpha$ -glucose molecule and a fructose molecule
- **lactose** (milk sugar) is derived from a  $\beta$ -glucose molecule and an  $\alpha$ -galactose molecule.

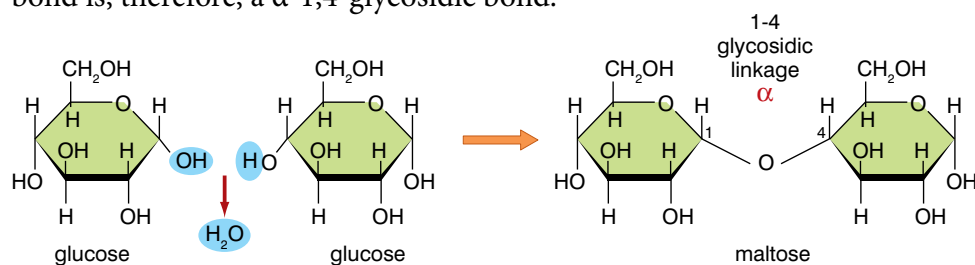
In each of these examples, two hexose monosaccharides have reacted to form a disaccharide molecule. As the formula of a hexose



**Figure 2.20** The structures of three disaccharides

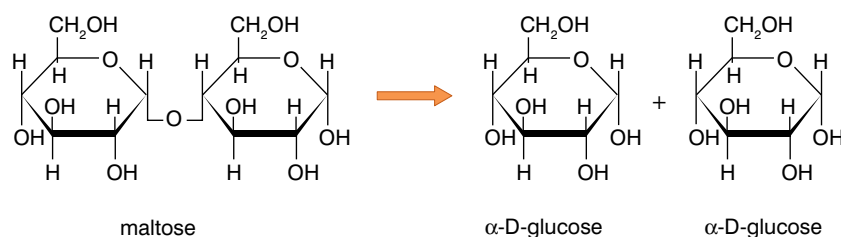
is  $C_6H_{12}O_6$ , you might expect the formula of the disaccharides to be  $C_{12}H_{24}O_{12}$ . In fact, the formula is  $C_{12}H_{22}O_{11}$ . A molecule of water ( $H_2O$ ) is formed from a hydroxyl group from one monosaccharide and a hydrogen atom from the other (figure 2.21). This allows a bond to be formed between the two monosaccharide units to make a disaccharide.

The process shown in Figure 2.21 is **condensation**. The bond that holds the two monosaccharide units together is a **glycosidic bond**. It is formed between carbon atom 1 of one  $\alpha$ -glucose molecule and carbon atom 4 of the other  $\alpha$ -glucose molecule. The full name of the bond is, therefore, a  $\alpha$ -1,4-glycosidic bond.



**Figure 2.21** Two molecules of  $\alpha$ -glucose are joined to form a molecule of maltose (a disaccharide).

The reverse process is hydrolysis (of the disaccharide). This involves 'putting back' the water that was removed during condensation and splitting the molecule into its component, smaller molecules (figure 2.22). This is another example of the use of water to split molecules.



**Figure 2.22** Hydrolysis of maltose

**Polysaccharides** are complex carbohydrates. Their molecules are built as many hundreds of monosaccharide molecules join together by forming condensation links. Starch is a polymer of  $\alpha$ -glucose.

Some polysaccharides are storage molecules. These offer a convenient way of storing carbohydrates that will not interfere with the metabolism of cells. Others are structural carbohydrates. As the name suggests, these carbohydrates are used to build structures – like plant cell walls and insect exoskeletons.

### KEY WORDS

**condensation** the process in which two molecules combine to form a larger molecule, producing a smaller molecule (often water) as a by-product

**glycosidic bond** the bond that holds two monosaccharide units together

**polysaccharide** a carbohydrate whose molecules consist of a number of monosaccharide molecules bonded together

Condensation does not just occur in the formation of disaccharides, but also in the formation of polysaccharides and other large molecules.

## KEY WORDS

**amylose** a long unbranched chain of  $\alpha$ -glucose molecules

**amylopectin** a chain of  $\alpha$ -glucose molecules with many branches

## DID YOU KNOW?

A **macromolecule** is just what you might think – it is a big molecule. Examples include proteins, starch, cellulose, glycogen and DNA. A polymer is also a large molecule – but it is not *just* large. A polymer molecule is made from many smaller, usually *identical*, molecules called **monomers**. Besides being macromolecules, starch, glycogen, cellulose and proteins are polymers. Starch and glycogen are polymers of  $\alpha$ -glucose, cellulose is a polymer of  $\beta$ -glucose and proteins are polymers of amino acids.

## Starch

Starch is not a single compound but a mixture of **amylose** and **amylopectin**. Both are polymers of  $\alpha$ -glucose, but the arrangement of the  $\alpha$ -glucose monomers in these compounds is different.

*Amylose* is a linear molecule containing many hundreds of  $\alpha$ -glucose molecules joined by  $\alpha$ -1,4-glycosidic bonds. As it is being formed, this long chain winds itself into a helix.

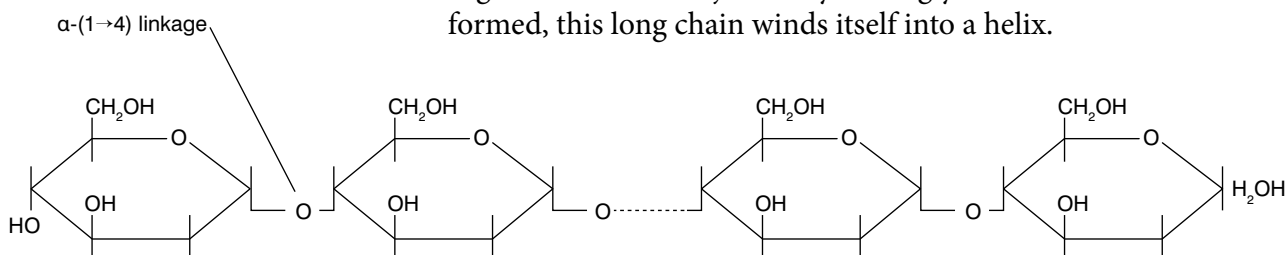
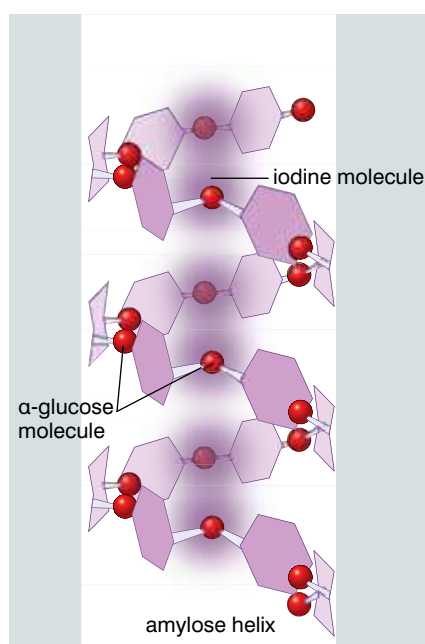


Figure 2.23 Linkages in amylose



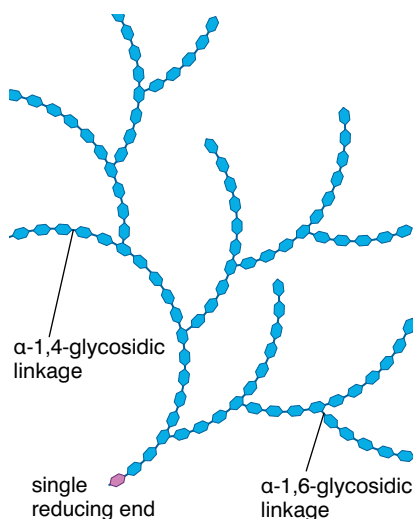
## Why starch stains blue or black or blue-black with iodine

The amylose molecule winds itself into a helix when in contact with water. This allows a reaction to occur between the starch and the iodine solution. Rows of iodine atoms sit inside the amylose helix. This changes the light-absorbing properties of both, so that the amylose–iodine complex appears blue. Starches in different plants have different proportions of amylose and amylopectin. This results in different shades of blue-black with the iodine test, because only the amylose reacts with iodine.

Figure 2.24 Iodine stains starch blue-black.

*Amylopectin* also has a linear ‘backbone’ of  $\alpha$ -glucose molecules joined by  $\alpha$ -1,4-glycosidic bonds. But in amylopectin, there are also side branches. These occur at certain points along the chain when a glucose molecule forms an  $\alpha$ -1,6-glycosidic bond with another glucose molecule *as well as* the usual  $\alpha$ -1,4-glycosidic bond. This results in amylopectin having a branching structure as shown in figure 2.25.

The branched nature of amylopectin means that there are many ‘ends’ to the molecule. This allows it to be quickly hydrolysed by enzymes acting at the ends of the chains to release glucose for respiration.



**Figure 2.25** The structure of amylopectin

### How the structure of starch is suited to its function

Starch is a plant storage carbohydrate. How does its structure suit it to this function?

- Both amylose and amylopectin are compact molecules, so many  $\alpha$ -glucose molecules can be stored in a small space, without affecting cell metabolism.
- Both amylose and amylopectin are insoluble. If soluble glucose were stored (instead of first being converted to starch), it would draw water, by osmosis, from neighbouring cells and from organelles within the cell. Insoluble starch produces none of these effects.
- In addition, because amylose and amylopectin are insoluble, the molecules cannot move out of cells – they remain in storage organs.
- The branched nature of amylopectin means that there are many ‘ends’ to the molecule. Therefore, starch can be quickly hydrolysed (by enzymes acting at the ends of the chains) to release glucose for respiration.

### DID YOU KNOW?

An enzyme that digests proteins is a *protease*; one that digests lipids is a *lipase*. An enzyme that digests starch is an *amylase* because it acts on the *amylose* and *amylopectin* that make up starch.

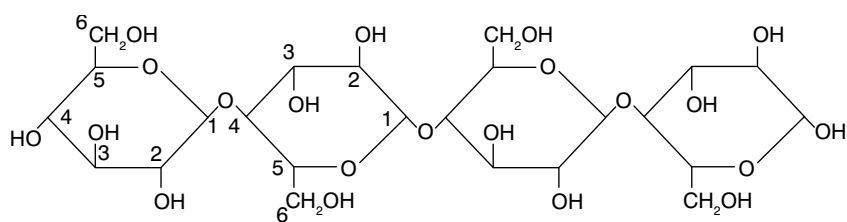
## Glycogen

Glycogen is a storage carbohydrate in animal cells. It has a similar structure to that of amylopectin – but there are more  $\alpha$ -1,6 links, making it much more highly branched. Because of this, it can be hydrolysed even more quickly to release glucose for respiration. This is important because animals have a higher metabolic rate than plants and need to release energy more quickly to ‘drive’ their metabolic processes.

## Cellulose

Cellulose is a polymer of  $\beta$ -glucose molecules joined by  $\beta$ -1,4-glycosidic bonds, formed by condensation reactions. However, because of the different position of the H and OH groups on carbon atom 1 compared to  $\alpha$ -glucose, every other glucose unit in the

chain is upside down, as shown in figure 2.26. Also, the chain is unbranched.



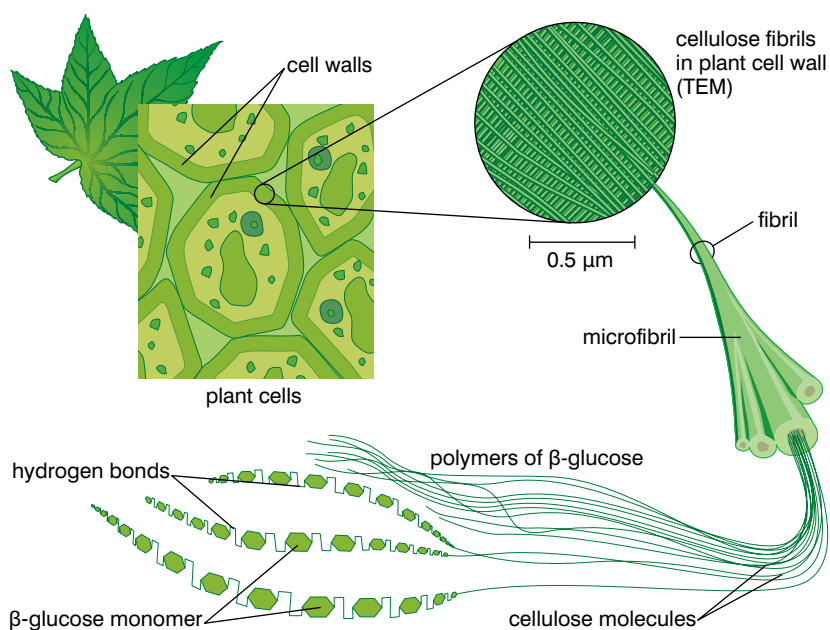
cellulose: 1-4 linkage of  $\beta$ -glucose monomers

**Figure 2.26** The structure of cellulose

Many cellulose molecules lie side by side and hydrogen-bond to each other. This results in the formation of cellulose microfibrils. Many of these microfibrils bond together to form bigger fibres or fibrils, which make up the structure of cell walls. This is shown in figure 2.27.

### Activity 2.5

Carbohydrates are very important biological molecules. Make a poster titled CARBOHYDRATES which explains the basic structure of carbohydrates and why they are important to plants and animals.



**Figure 2.27** How cellulose molecules are organised in plant cell walls

### How the structure of cellulose is suited to its function

The cellulose molecule is unbranched. This allows hydrogen bonding and the formation of microfibrils. If it were branched, microfibrils could not form. It is the fibrous nature of cellulose that gives the cell walls their strength, but also gives them some flexibility.

## What are lipids?

Like carbohydrates, nearly all lipids contain only the elements carbon, hydrogen and oxygen, but they contain *much* less oxygen than carbohydrates.

Lipids are a varied group of compounds that include:

- **triglycerides** – formed from glycerol and three fatty acids
- **phospholipids** – formed from glycerol, two fatty acids and a phosphate group
- **waxes** – formed from fatty acids and long-chain alcohols

Whilst some lipids have quite large molecules, they are not polymers and, in many cases, their molecules are relatively small. 'The feature that they all share is that are all made from fatty acids and alcohols.

Because of their varied nature, lipids have a range of functions.

Waxes are so insoluble in water that they make excellent water repellents, for example, in coating birds' feathers and the epidermis of the leaves of plants (the waxy cuticle).

Phospholipids are one of the basic components of all cell membranes.

Triglycerides have several functions including:

- respiratory substrate – a molecule of triglyceride yields over twice as many molecules of ATP (twice as much energy) as a molecule of glucose
- thermal insulation – the cells of adipose tissue found under the skin of many animals contain large amounts of triglycerides, which give good thermal insulation
- buoyancy – lipids are less dense than water (oil floats on water), so the presence of large amounts of lipid reduces the density of an animal, making it more buoyant
- waterproofing – the oils secreted by some animals onto their skin are triglycerides

## Triglycerides

A triglyceride molecule is an ester formed from one molecule of glycerol and three fatty acid molecules.

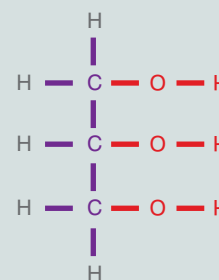
A fatty acid molecule consists of a **covalently bonded hydrocarbon chain**, at the end of which is a **carboxyl group**, which has acidic properties. The hydrocarbon chain is non-polar (this means that it has no charge). The carboxyl group (the functional group of the fatty acid) is ionic and dissociates in solution to form  $\text{COO}^-$  and  $\text{H}^+$  (hydrogen ion). The hydrogen ions released make the solution acidic.

**Figure 2.29** The structure of a triglyceride

## DID YOU KNOW?

Some of the lipids found in the myelin sheath that surrounds nerve cells are **sphingolipids**. These are unusual lipids as they contain nitrogen as well as carbon, hydrogen and oxygen.

Glycerol is a polyhydroxy alcohol. This means it contains more than one hydroxyl ( $-\text{OH}$ ) group. Ethanol, the alcohol in beer and wine, has the formula  $\text{C}_2\text{H}_5\text{OH}$ . It is a monohydroxy alcohol and contains only one hydroxyl group:

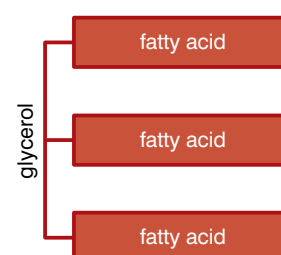


**Figure 2.28** The structure of glycerol

## KEY WORDS

**covalently bonded hydrocarbon chain** a chain of carbon atoms, covalently bonded to each other and to one, or more, hydrogen atoms

**carboxyl group** acid radical  $-\text{COOH}$ . It releases  $\text{H}^+$  into aqueous solution to make the solution acidic



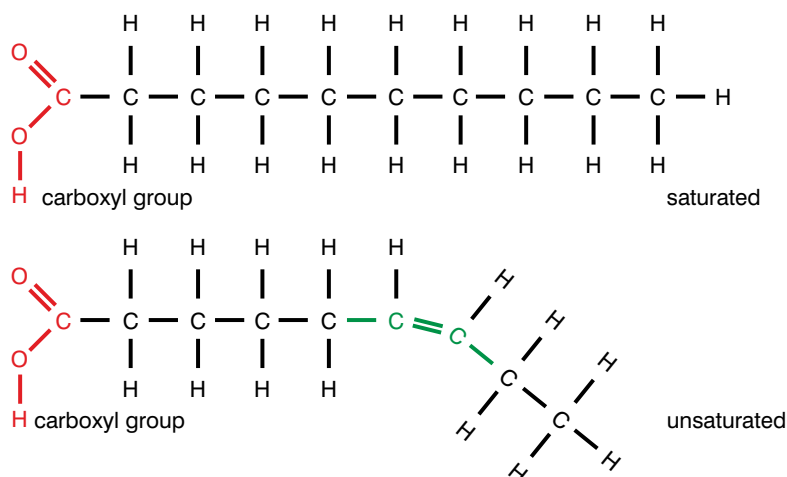
**KEY WORDS**

**saturated fatty acid** *all the carbon-carbon bonds in the hydrocarbon chain are single bonds*

**monounsaturated fatty acid** *one of the carbon-carbon bonds is a double bond*

**polyunsaturated fatty acid** *more than one carbon-carbon bond is a double bond*

**ester bond** *the bond that forms between a carboxyl group and a hydroxyl group*



**Figure 2.30** The structure of fatty acids

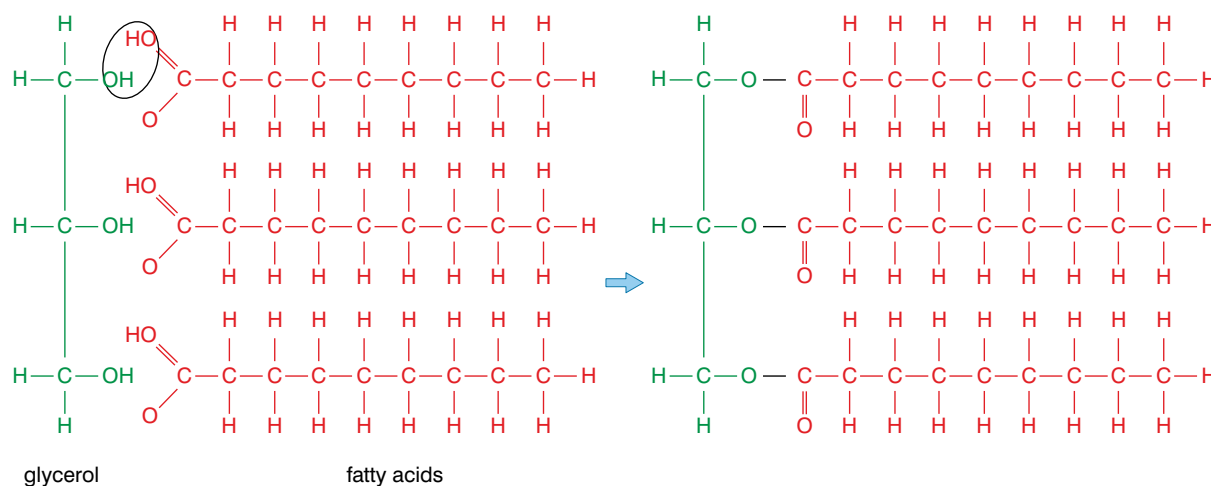
The nature of the hydrocarbon chains in fatty acids can differ in two main ways:

- The number of carbon atoms in the chains can vary.
- Hydrocarbon chains with the same number of carbon atoms can have different numbers of hydrogen atoms.

This is because of the nature of the bonding between the carbon atoms in the chain. If all the carbon-carbon bonds in the hydrocarbon chain are single bonds, the fatty acid is a **saturated fatty acid**. If one of the carbon-carbon bonds is a double bond, then it is a **monounsaturated fatty acid**. If more than one carbon-carbon bond is a double bond, then the fatty acid is a **polyunsaturated fatty acid**.

Sometimes we wish to represent a 'generalised fatty acid'. This means a diagram that shows the general arrangement of the molecule, including the functional group, but that could have any number of carbon atoms in the hydrocarbon chain.

When triglyceride molecules are formed, condensation reactions take place to join three fatty acid molecules to a glycerol molecule. The bonds formed are called **ester bonds**. These ester bonds can be broken by hydrolysis to give glycerol and fatty acids once again.



**Figure 2.31** The formation of a triglyceride.

**DID YOU KNOW?**

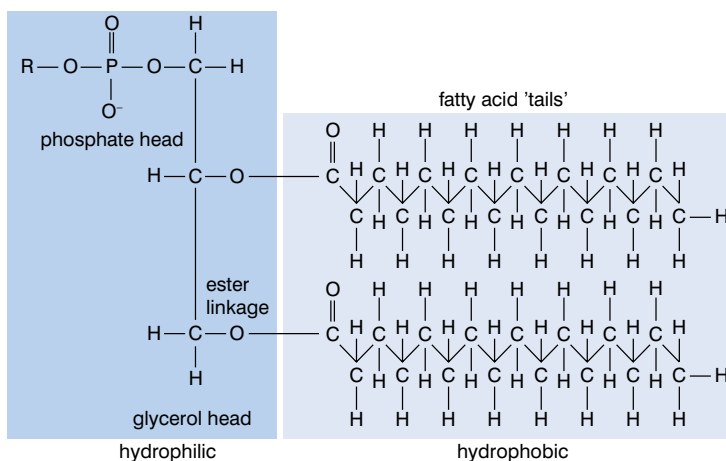
You may have seen cooking oils, margarines and other spreads advertised as 'high in polyunsaturates'. This means that the lipids in them contain a high proportion of polyunsaturated fatty acids. Polyunsaturated fatty acids help to prevent cholesterol being laid down in the linings of arteries (atherosclerosis) and so help to prevent heart disease.



## Phospholipids

Phospholipids are formed when two fatty acid molecules are bonded to the glycerol and the place of the third is taken by a phosphate group. Since the phosphate group is ionic and the hydrocarbon chains of the two fatty acids are covalently bonded, there are two distinct regions to a phospholipid molecule:

- a **hydrophilic** (water-loving) region, consisting of the phosphate 'head'
- a **hydrophobic** (water-hating) region, consisting of the hydrocarbon 'tails'



In water, phospholipids become organised into a **bilayer** (two layers sandwiched together). In this configuration, the hydrophilic heads face outwards into the water and the hydrophobic tails face inwards, away from the water. Phospholipid bilayers are the basis of plasma membranes. We will study these in detail in unit 4.

Notice how the structure of a phospholipid has been simplified in figure 2.33. The phosphate head is shown as a ball and the fatty acids as two tails. The glycerol 'backbone' somehow gets lost in the simplification!

### Why do we need proteins?

Proteins are extremely important substances that are needed to form all living cells. Their molecules contain the elements carbon, hydrogen and oxygen (like carbohydrates and lipids), but they also contain nitrogen and most contain sulphur. Protein molecules are polymers of **amino acids** and so are macromolecules also. But they vary enormously in size; the smallest protein molecules contain fewer than 100 amino acids, whilst the largest contain several thousand.

Proteins have a range of functions; they are important in:

- the structure of plasma membranes – protein molecules form ion channels, transport proteins and surface receptors for hormones, neurotransmitters and other molecules
- the immune system – antigen and antibody molecules are proteins

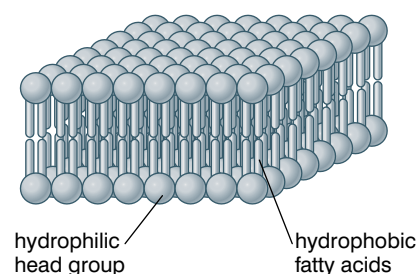
### KEY WORDS

**hydrophilic** *water-loving*  
**hydrophobic** *water-hating*  
**bilayer** *two layers sandwiched together*

### Activity 2.6

Make a poster titled LIPIDS which explains the basic structure of lipids and why they are important to plants and animals.

**Figure 2.32** The structure of a phospholipid



**Figure 2.33** The structure of a phospholipid bilayer

### KEY IDEA

It is the dual hydrophilic–hydrophobic nature of phospholipids that makes them organise into bilayers. Without this property, cell membranes would not be formed.

It is not strictly true to call proteins polymers. In a true polymer, all the monomers are identical (think of amylose and amylopectin in starch, where all the monomers are  $\alpha$ -glucose). However, there are usually several different amino acids in any given protein molecule. But, since all amino acids have the same basic structure, we usually refer to proteins as polymers.

### KEY WORDS

**amino acids** are the building blocks of proteins and have two functional groups – the amino group and the carboxyl group. This allows them to behave both as a base and as an acid

**peptide bond** the bond that links two amino acids

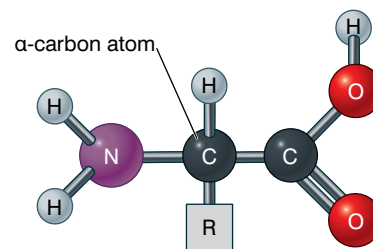
**polypeptide** a linear polymer consisting of amino acid residues bonded together in a chain forming a part or all of a protein molecule

**primary structure** the sequence formed by amino acids

- the control of metabolism by enzymes – all enzymes are proteins
- the structure of chromosomes – DNA is wound around molecules of the protein histone to form a chromosome

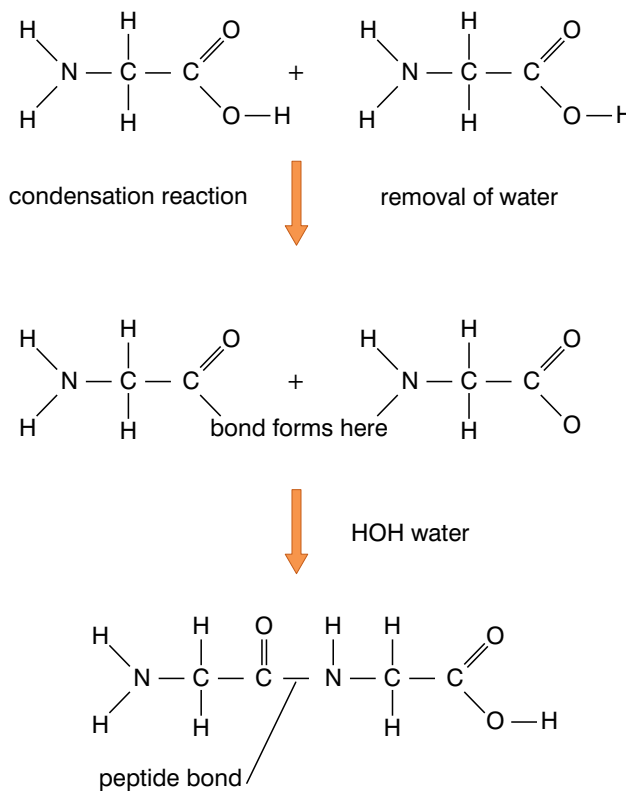
All amino acid molecules are built around a carbon atom (the  $\alpha$ -carbon) to which is attached:

- a hydrogen atom
- an amino group ( $-\text{NH}_2$ )
- a carboxyl group ( $-\text{COOH}$ )
- an 'R' group, which represents the other atoms in the molecule, such as a single hydrogen atom, a hydrocarbon chain or a more complex structure



**Figure 2.34** The general structure of an amino acid

Two amino acids can be joined together by condensation to form a dipeptide. This takes place in much the same way as when two monosaccharides join to form a disaccharide. H and OH are lost to create a molecule of water. The 'H' is lost from the amino group on one amino acid and the 'OH' is lost from the carboxyl group on the other amino acid. 'Spare bonds' are created on each molecule, which then join to form a **peptide bond**, which holds the two amino acids together. This is shown in figure 2.35.



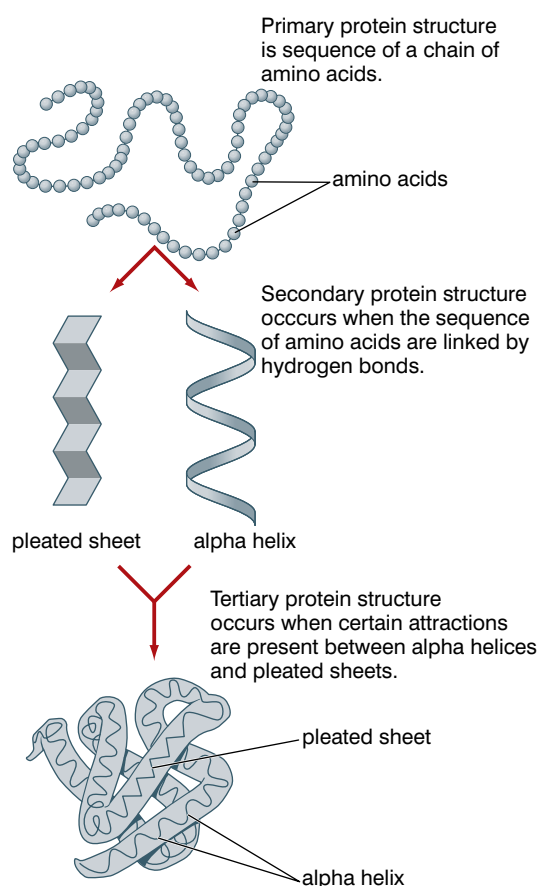
**Figure 2.35** How a dipeptide is formed

A dipeptide can be enlarged into a **polypeptide** by condensation with more amino acid molecules. Many amino acids joined by peptide bonds form a polypeptide chain; this sequence of amino acids is the **primary structure** of the protein. Once formed, the polypeptide chain folds itself into a **secondary structure**, which is either an  **$\alpha$ -helix** or a  **$\beta$ -pleated sheet** (see figure 2.36). The structures are held in place by hydrogen bonds that form between peptide bonds in adjacent parts of the amino acid chain. Both types of secondary structure can exist in different regions of the same polypeptide chain.

A protein molecule can also have a **tertiary structure**. This involves further folding of the secondary structure and the formation of new bonds to hold the tertiary structure in place.

These new bonds include:

- more hydrogen bonds – between the R-groups of some amino acids
- disulphide bridges – between amino acids that contain sulphur
- ionic bonds – between amino acids with positively charged R-groups and those with negatively charged R-groups



**Figure 2.36** The levels of structure of a protein

Each protein has a unique tertiary structure and so has a unique configuration (shape) because:

- the primary structure of each protein is coded for by DNA, which determines the type and position of each amino acid in the polypeptide chain

### KEY WORDS

**secondary structure** formed when a polypeptide chain folds itself into another structure

**$\alpha$ -helix** a coiled secondary structure of a polypeptide

**$\beta$ -pleated sheet** a folded secondary structure of a polypeptide

**tertiary structure** folding of the secondary structure of a polypeptide by the formation of new bonds to hold it in place

**quaternary structure** structures formed when two or more polypeptide chains (folded into a tertiary structure) become associated in the final structure of the protein

**KEY WORDS**

**haemoglobin** *the oxygen-carrying molecule in the blood*

**collagen** *fibrous protein found in many tissues in mammals*

**DNA** *a huge molecule made up of two strands of nucleotides wound into a double helix*

**RNA** *a molecule made up of one strand of nucleotides*

**Activity 2.7**

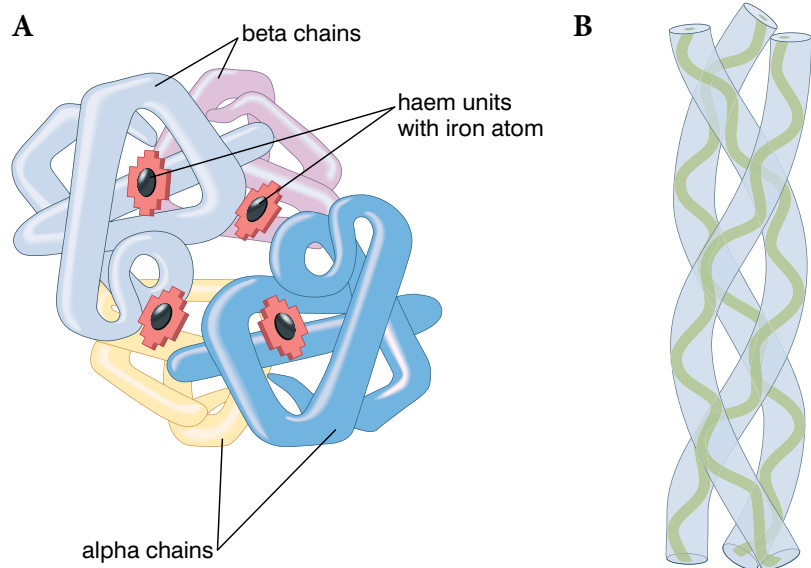
Make a poster titled **PROTEINS** which explains the basic structure of proteins and why they are important to plants and animals.

- the secondary structure of the molecule is the consequence of its primary structure; some sections of the primary structures form  $\alpha$ -helices, others form  $\beta$ -pleated sheets, and
- the secondary structure determines where ionic and hydrogen bonds and disulphide bridges form, so it determines the tertiary structure and shape of the protein molecule.

The tertiary structure of a protein is unique and this gives each protein a specific function. For example:

- the shape of the active site of an enzyme molecule lets it bind with only one substrate and catalyse only one reaction
- the shape of a hormone receptor in the plasma membrane of some cells allows the hormone to bind with this receptor and to target *only* cells that have this receptor
- the shape of an antibody means it can bind with and destroy just one antigen

Some proteins have yet another level of organisation called the **quaternary structure**. In these proteins two, or more, polypeptide chains folded into a tertiary structure become associated in the final structure of the protein. Two important examples are **haemoglobin** (the oxygen-carrying molecule found in red blood cells) and **collagen** (the fibrous protein found in many tissues in mammals).



**Figure 2.37A** The four polypeptides in haemoglobin's quaternary structure; **B** The three polypeptides in collagen's quaternary structure

Proteins are classified into two main groups, according to their molecular shapes:

- **fibrous proteins** that have a tertiary structure that resembles a long string or fibre (for example, collagen and keratin)
- **globular proteins** that have a tertiary structure that resembles a globule or ball (for example, enzymes and receptor proteins).

## What are nucleic acids?

Biologists discovered two different types of nucleic acid at the end of the nineteenth century:

- **DNA or DeoxyriboNucleic Acid** – DNA is the nucleic acid found in chromosomes. Each gene is a short section of DNA that codes for a specific protein and, as a result, determines a particular feature. DNA is the genetic material.
- **RNA or RiboNucleic Acid** – RNA is a nucleic acid found both in the nucleus and the cytoplasm. Different types of RNA are involved in allowing a specific gene (DNA) to produce the protein it codes for.

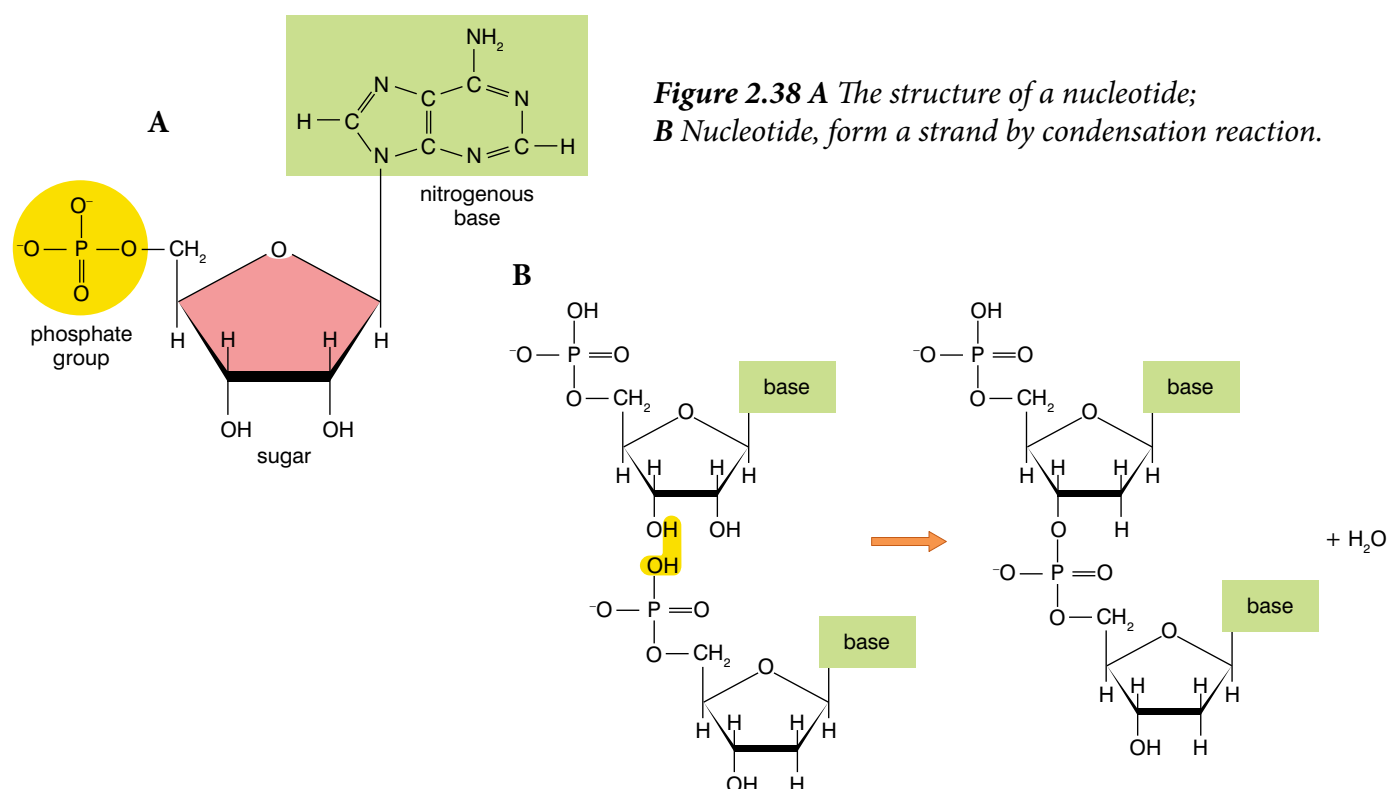
DNA was isolated from animal cells and RNA from yeast cells. It was not until much later that biologists realised that both types are present in all living cells. We shall study the structure and functioning of nucleic acids in more detail in grade 12, but they are very important biological molecules, so we will just outline their structure and functions now. Both types of nucleic acids are made from structures called nucleotides. All nucleotides have the same basic structure.

All nucleotides have the same three components:

- a phosphate group
- a pentose sugar (deoxyribose in DNA nucleotides and ribose in RNA nucleotides), and
- one of four nitrogenous bases – Adenine, Cytosine, Guanine and either Thymine (DNA) or Uracil (RNA).

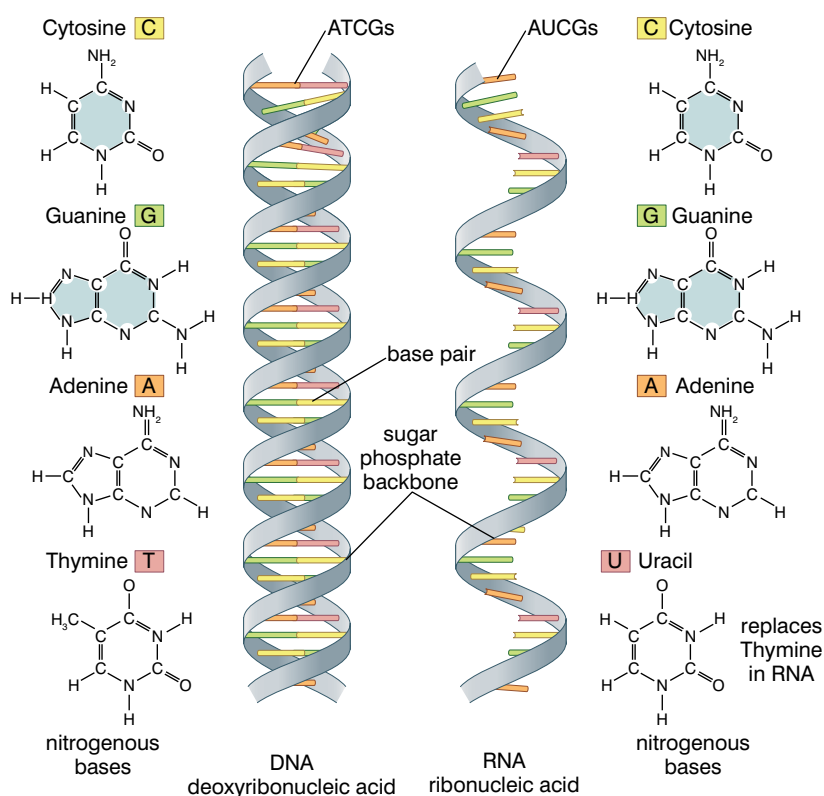
DNA is a huge molecule made up of two strands of nucleotides wound into a double helix. RNA is much smaller and is single-stranded.

Figure 2.39 overleaf shows the structures of both.



**Figure 2.38 A** The structure of a nucleotide;  
**B** Nucleotide, form a strand by condensation reaction.

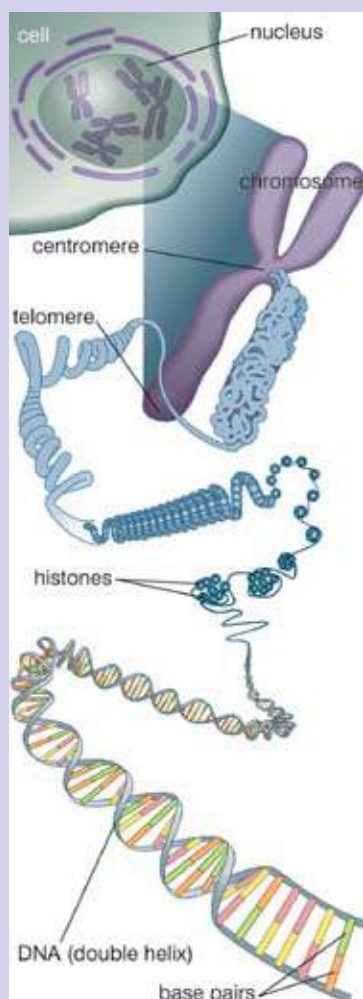
**Figure 2.39** The structures of DNA and RNA



### DID YOU KNOW?

#### How DNA is organised in a cell

DNA is found only in the nucleus of a cell. It is associated with proteins called histones to form chromosomes. This is shown in figure 2.40.



**Figure 2.40** Where DNA is found in a cell

**Table 2.3** How the structure of nucleic acids relates to their functions

Feature	DNA	RNA
Size	Huge – allows the molecule to carry the code for many different proteins in the genes.	Much smaller – need only code for one protein; small size allows RNA to move out of the nucleus.
Stability	Very stable – ensures that the genes remain the same over generations.	Less stable – is degraded quite quickly so does not carry on coding for a protein.
Number of strands	Two strands – allows coding of genes and replication during cell division.	Single stranded – does not replicate.

### How can we find out which biological molecules are in foods?

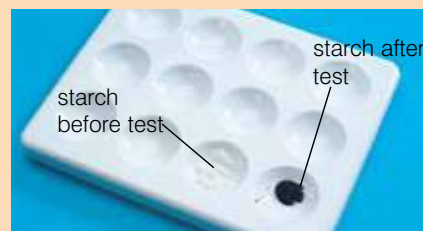
There are biochemical tests for a range of biological molecules. These include:

- starch
- reducing sugars
- non-reducing sugars
- lipids
- proteins.

**Activity 2.8: The iodine test for starch**

Starch reacts with a solution of iodine in potassium iodide to give a blue-black colour.

1. Place the solution or food to be tested in a spotting tray/test tube.
2. Add a few drops of iodine solution.
3. Look for a blue-black colour.



**Figure 2.41** Result of the starch test

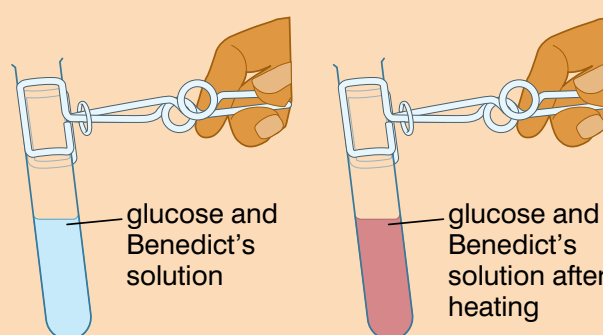
**Activity 2.9: The Benedict's test for reducing sugars**

Reducing sugars include glucose, fructose, maltose, lactose, but not sucrose (the disaccharide sugar we use on a day-to-day basis in tea and coffee).

Place the solution or food to be tested in a test tube (about 1 cm depth is sufficient).

1. Add 5 cm<sup>3</sup> Benedict's solution.
2. Stand the test tube in a water bath for five minutes.
3. Observe the colour.

A yellow/orange/red colour shows that a reducing sugar is present.



**Figure 2.42** Result of the Benedict's test

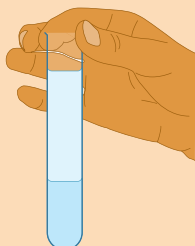
It is important to note that the Benedict's test does not distinguish between different reducing sugars. It is *not* a test for glucose – or galactose or any individual sugar. To distinguish between individual sugars, enzyme-based tests are used.

**Activity 2.10: The Benedict's test for non-reducing sugars**

1. First, we must establish that no reducing sugars are present. The test is carried out as described above. If the solution remains blue, there can be no reducing sugars present.
2. Then, boil 5 cm<sup>3</sup> of the test sample with 5 cm<sup>3</sup> of hydrochloric acid to hydrolyse any molecules of non-reducing sugar.
3. Neutralise the solution by adding sodium carbonate (remember, the reducing sugars will not reduce Benedict's solution in acidic conditions).
4. Retest the mixture with Benedict's solution. A red precipitate indicates that reducing sugars are now present. As they weren't present at the start, they must have been formed by the acid hydrolysis. So, at the start, a *non-reducing* sugar must have been present.

**DID YOU KNOW?****Reducing sugars**

They are called reducing sugars because they will act as reducing agents in an alkaline solution. This is the basis of the Benedict's test. In this test, reducing sugars reduce copper (II) ions (blue) to copper (I) ions (brick red).

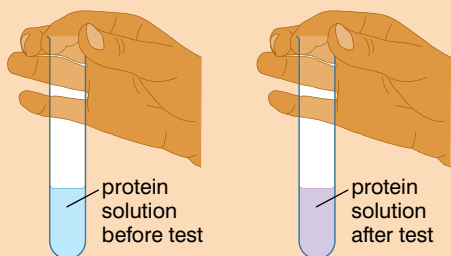
**Activity 2.11: The emulsion test for lipids**

**Figure 2.43** Result of the emulsion test

This test is based on the fact that lipids are soluble in organic solvents such as ethanol, but insoluble in water. This test is carried out as follows.

1. Shake the test sample with 5 cm<sup>3</sup> ethanol, in a clean, dry test tube.
2. Filter the mixture (if necessary).
3. Pour the filtrate into water.

Any lipid in the filtrate will not dissolve in the water. It will form an emulsion that makes the liquid appear milky white.

**Activity 2.12: The Biuret test for proteins**

**Figure 2.44** Result of the Biuret test

In this test, a protein in an alkaline solution reacts with copper ions to produce a mauve/purple colour. There are two ways of carrying out the test:

**Method 1**

1. Mix the food or 2 cm<sup>3</sup> of the test solution with sodium hydroxide solution in a test tube.
2. Add a few drops of 1% copper (II) sulphate solution.
3. Allow the mixture to stand for a few minutes (to allow the colour to develop fully).

**Method 2**

1. Mix the food or 2 cm<sup>3</sup> of the test solution with Biuret solution (which contains copper ions in an alkaline solution).
2. Allow the mixture to stand for a few minutes to allow the colour to develop fully.

**Activity 2.13: Library search**

Clinistix is an example of a biosensor-based test for glucose. Try to find out how it works.



## Review questions

Choose the correct answer from A to D.

- Hexoses are:
  - disaccharides with molecules that contain six carbon atoms
  - monosaccharides with molecules that contain six oxygen atoms
  - monosaccharides with molecules that contain six carbon atoms
  - disaccharides with molecules that contain six oxygen atoms
- The main advantage of the high level of branching in a molecule of amylopectin is that:
  - the many 'ends' allow rapid hydrolysis
  - much can be stored in a small space
  - there are no osmotic effects
  - it is insoluble
- The secondary structure of a protein can be:
  - a globular or a fibrous structure
  - a specific sequence of amino acids
  - a dipeptide
  - an  $\alpha$ -helix or a  $\beta$ -pleated sheet
- Condensation involves:
  - the creation of new bonds with the addition of a molecule of water
  - the creation of new bonds with the loss of a molecule of water
  - the breaking of existing bonds with the addition of a molecule of water
  - the breaking of existing bonds with the loss of a molecule of water
- A food gives a positive result when tested with the Biuret test, and an initial negative result when tested with Benedict's solution. Following acid hydrolysis and neutralisation, the food gave a negative test with Benedict's solution. The food contains:
  - protein and a non-reducing sugar
  - protein and a reducing sugar
  - protein, a reducing sugar and a non-reducing sugar
  - protein only

## Activity 2.14

Work in groups of four. You are going to debate the importance of the four groups of biological molecules highlighted in this chapter – carbohydrates, lipids, proteins and nucleic acids. Each of you takes one of these types of molecules and spends about 5 minutes planning a short speech explaining why it is the most important type of biological molecule. Then listen to each other's speeches and take a vote on the most important. Record the results of your vote – how many votes each type of molecule gets.

Set up a tally chart of the board and add together the results from all the different groups. Which type of molecule won – or was it a draw? Discuss the outcome of the class voting.

6. In a saturated fatty acid:
  - A there are only single bonds between carbon atoms
  - B there is one double bond between carbon atoms
  - C there is one triple bond between carbon atoms
  - D there is more than one double bond between carbon atoms
7. Phospholipids form bilayers in water because:
  - A the hydrophilic head is repelled by the water and the hydrophobic tail is attracted by it
  - B the hydrophilic head is attracted by the water and the hydrophobic tail is repelled by it
  - C both the hydrophilic head and the hydrophobic tail are attracted by the water
  - D both the hydrophilic head and the hydrophobic tail are repelled by the water
8. When heated with Benedict's solution, sucrose does not cause a colour change because it is:
  - A a reducing sugar
  - B a disaccharide
  - C a non-reducing sugar
  - D a compound sugar
9. A triglyceride molecule is an ester of:
  - A three fatty acids and ethanol
  - B two fatty acids and glycerol
  - C two fatty acids and ethanol
  - D three fatty acids and glycerol
10. DNA is made from:
  - A a single polynucleotide chain
  - B a single chain of amino acids
  - C two chains of amino acids
  - D two polynucleotide chains
11. The functional group of a fatty acid is:
  - A a ketone group
  - B an aldehyde group
  - C a carboxyl group
  - D an amino group

12. DNA differs from RNA in that it (DNA) is:
- A larger and double stranded
  - B smaller and double stranded
  - C smaller and single stranded
  - D larger and single stranded
13. Maltose is a:
- A reducing monosaccharide sugar
  - B reducing disaccharide sugar
  - C non-reducing disaccharide sugar
  - D non-reducing monosaccharide sugar
14. The cellulose molecule is ideal for making cell walls because:
- A it is an unbranched molecule
  - B molecules can hydrogen-bond with other cellulose molecules
  - C the molecules are relatively unreactive
  - D all of the above
15. A student carried out four biochemical tests to investigate the composition of onion, biscuit, potato and banana. The results are shown in the table. A ✓ indicates a positive result and a ✗ indicates a negative result.

Test	Onion	Biscuit	Potato	Banana
Add iodine solution	✗	✓	✓	✓
Boil with Benedict's solution	✓	✗	✗	✓
Ethanol emulsion test	✗	✓	✗	✗
Add Biuret reagent	✗	✓	✓	✗

Which food contained starch, lipid and protein?

- A onion
- B biscuit
- C potato
- D banana

**Activity 2.15**

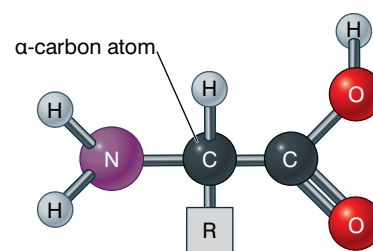
Drawings of biological molecules in your text book are two dimensional but they are actually 3-D structures. Using any materials you have available – clay, beads, paper, straws – make simple 3-D models of the following: water, glucose, a general amino acid (see p62).

**Summary**

In this unit you have learnt that:

- Organic molecules always contain carbon and hydrogen.
- The most common elements in living tissue are carbon, hydrogen, oxygen, nitrogen, sulphur and phosphorus.
- Atoms are the simplest particles of elements; they can join together to form molecules.
- Elements only contain one kind of atom.
- Compounds are made from molecules containing atoms joined together in a fixed ratio.
- Water is the most abundant substance on Earth; it covers three-quarters of the Earth's surface.
- Water has the chemical formula  $H_2O$ ; the molecules can hydrogen-bond with each other.
- Water has several properties that are important to living things:
  - transparency allows light to penetrate, which allows water plants to photosynthesise
  - a high surface tension allows organisms to live on and just below the surface
  - a high specific heat capacity means that water does not heat up or cool down too quickly
  - a high latent heat of vaporisation means that water takes in a lot of energy when it is turned to a vapour
  - ice is less dense than liquid water, so ponds freeze from the top down allowing life to continue under the ice
  - it is a good solvent, allowing reactions to occur and making it ideal as a transport medium
  - it is a reactant in many reactions, including photosynthesis and all hydrolysis reactions (for example, those of digestion)
  - it has a low (but not too low) viscosity, again making it ideal as a transport medium.
- Carbohydrate molecules contain the elements carbon, hydrogen and oxygen only. The ratio of hydrogen atoms to oxygen atoms is 2:1.
- Monosaccharides are carbohydrates with atoms that are arranged in a single ring-like structure.
- The formula of  $\alpha$ -glucose and all other hexose monosaccharides is  $C_6H_{12}O_6$ .
- Two monosaccharides can be joined by condensation to form a disaccharide. In the formation of maltose, two  $\alpha$ -glucose molecules are joined with the loss of a molecule of water ( $H_2O$ ). The formula of maltose is  $C_{12}H_{22}O_{11}$ .

- The bond joining the two molecules of  $\alpha$ -glucose is an  $\alpha$ -1,4-glycosidic bond.
- Polysaccharides are formed when many monosaccharide molecules join by condensation.
- Starch contains two polymers of  $\alpha$ -glucose – amylose and amylopectin.
- Starch and glycogen are storage carbohydrates. They have compact molecules that enable much glucose to be stored in a small place. They are insoluble, which means that they have no osmotic effects within the cell and do not move from the cell.
- Amino acids contain carbon, hydrogen, oxygen and nitrogen. They have the general structure shown on the right.
- Amino acids can be joined by condensation. The bond between two amino acids is a peptide bond. A large number of amino acids joined in this way form a polypeptide.
- Proteins are polymers of amino acids. They have several levels of structure:
  - the primary structure is the sequence of amino acids in a polypeptide chain
  - the secondary structure is determined by the folding of the primary structure into either an  $\alpha$ -helix or a  $\beta$ -pleated sheet; these structures are held in shape by hydrogen bonds
  - the tertiary structure is determined by the further folding of the secondary structure into either a fibrous or a globular shape; these structures are held in place by further hydrogen bonds, disulphide bridges and ionic bonds
  - some have a quaternary structure in which two or more polypeptide chains, each with a tertiary structure, are bonded together; a haemoglobin molecule consists of four polypeptide chains bonded together
- A triglyceride molecule is an ester of three fatty acid molecules and one glycerol molecule; the ester bonds are formed by condensation.
- Fatty acid molecules can be either saturated (all carbon-carbon bonds are single), monounsaturated (one carbon-carbon double bond) or polyunsaturated (more than one carbon-carbon double bond).
- A phospholipid molecule consists of two fatty acids and a phosphate group bonded to a molecule of glycerol. The phosphate group gives the molecule a hydrophilic 'head' and the fatty acids give the molecule hydrophobic 'tails'.
- Phospholipid bilayers are the basis of biological membranes.
- Nucleic acids are made from nucleotides.

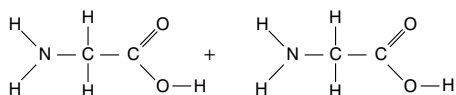


**Figure 2.45** General structure of amino acids

- DNA is a double-stranded nucleic acid; RNA is a single-stranded nucleic acid.
- Reducing sugars react with Benedict's solution when heated to give a yellow/orange/red precipitate.
- Non-reducing sugars must first be hydrolysed by boiling with HCl and then neutralised before they will react with Benedict's solution; they then give the same yellow/orange/red precipitate as reducing sugars.
- Proteins react with Biuret reagent to give a mauve/purple colour.
- The emulsion test for lipids produces a milky-white colour in water.

### End of unit questions

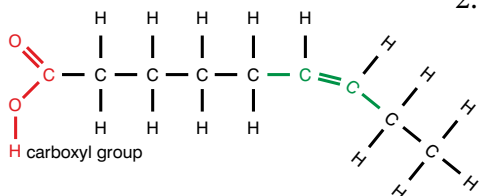
1. The diagram shows two amino acids.



- (i) Copy the diagram and indicate the amino group on one amino acid and the carboxyl group on the other.  
(ii) Draw another diagram to show how these amino acids could form a dipeptide.  
(iii) Name both the process involved in forming the dipeptide and the bond formed.

b) Explain what is meant by the quaternary structure of a protein.

2. The diagram shows the arrangement of the atoms in a fatty acid.



- Is the fatty acid a saturated fatty acid, monounsaturated or polyunsaturated? Give a reason for your answer.
- A molecule of this fatty acid contains more carbon atoms than a glucose molecule. Give three other differences between the two molecules.
- Explain how fatty acids are used to form:
  - triglycerides
  - phospholipids

3. a) Copy and complete the table.

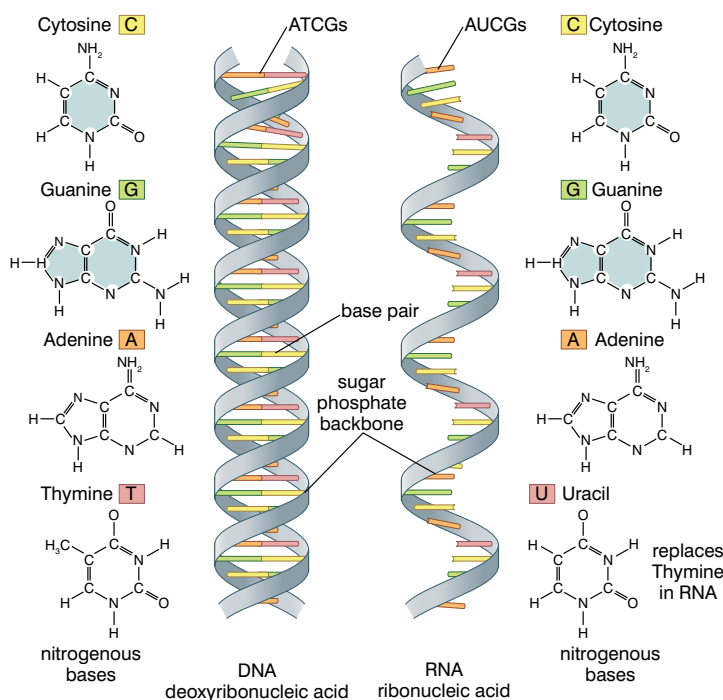
Organic substance	Solubility in water	Sub-units	Elements present
Glucose		(None)	
Starch			C, H, O
Triglyceride			
Protein	Variable	Amino acids	

- b) Describe how you would test a sample of powdered milk to see if it contained:
- reducing sugar
  - protein
4. Copy and complete the table, which describes the importance of some properties of water to living things.

Property	Importance to living things
High specific heat capacity	
Transparency	
	Takes a lot of energy to turn it to a vapour – allows temperature regulation by sweating
	Allows organisms to live at and just below the surface
Ice is less dense than liquid water	
	Allows many substances to dissolve and allows many reactions to take place

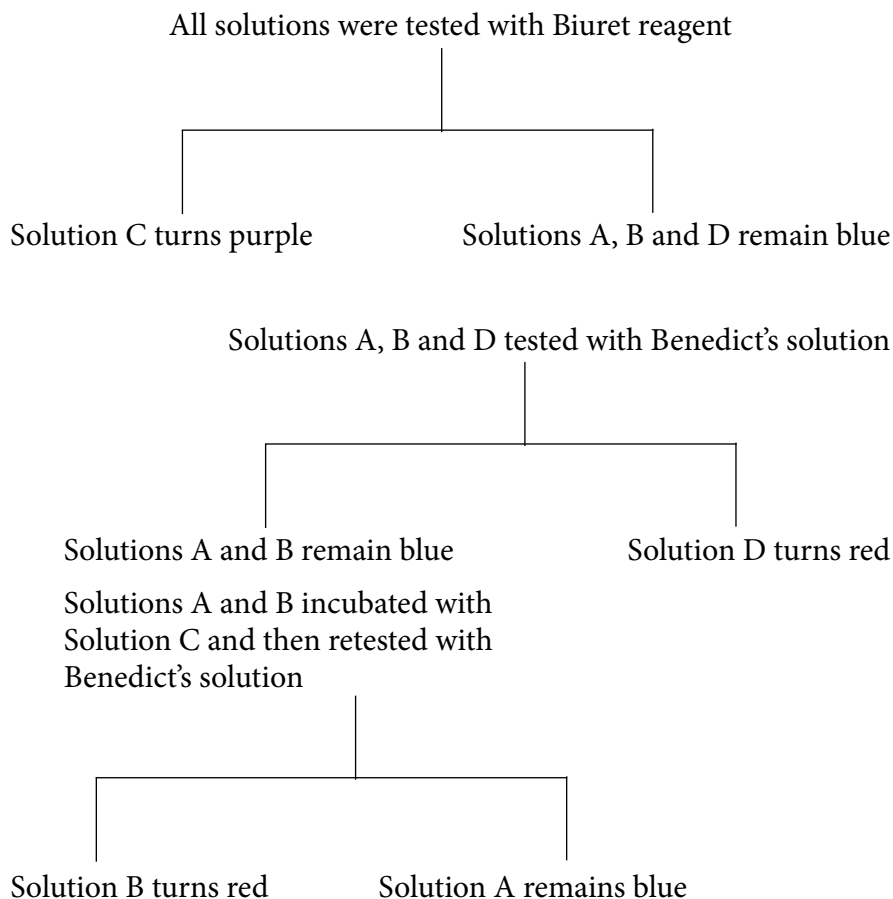
5. The diagram shows the molecules of DNA and RNA.

- Describe three differences between the two molecules that you can see in the diagram.
  - Where is DNA found in a cell?
  - How is the structure of DNA adapted to its function?
6. a) Describe the structure of starch and explain how its structure makes it ideal for its function as a storage carbohydrate.
- Describe three ways in which the structure of cellulose differs from the structure of starch.
  - Describe two ways in which the structure of glycogen differs from the structure of starch.



- Explain, with the aid of diagrams, how it is possible for glucose and fructose both to have the formula  $C_6H_{12}O_6$  and yet be different substances.
- What is meant by the term 'functional group'? Use two examples to illustrate your answer.
- Explain what is meant by the term  $\alpha$ -1,4-glycosidic link.

8. a) Four solutions were made up; one containing glucose, one containing starch, one containing amylase (a starch digesting enzyme) and one containing sucrose. Unfortunately, they were not labelled, except as solutions A, B, C and D. The following tests were carried out to identify the solutions.

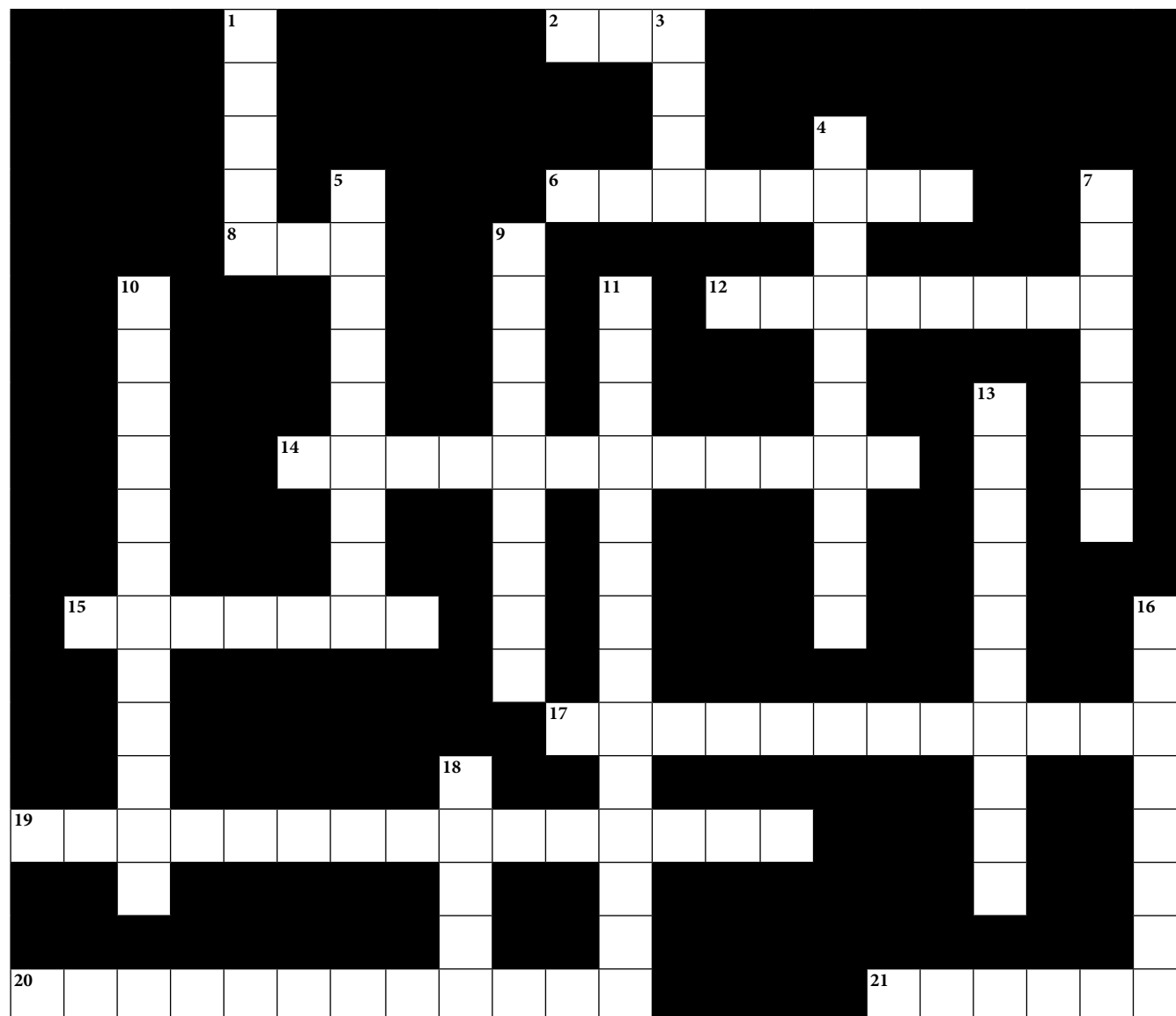


Identify, with reasons, the four solutions.

- b) (i) Describe the structure of a saturated triglyceride.  
 (ii) Describe three ways in which a phospholipid differs from a triglyceride.
- c) Describe three uses of lipids in living organisms.



Copy the crossword puzzle below into your exercise book (or your teacher may give you a photocopy) and solve the numbered clues to complete it.



### Across

2. Nucleic acid found both in the nucleus and in the cytoplasm (3)
6. A substance containing two or more chemical elements in a fixed ratio (8)
8. Nucleic acid that is the hereditary material (3)
12. A particle containing at least two atoms joined together (8)
14. Type of organic molecule often used for energy release (12)
15. The type of bond that holds amino acids together (7)
17. Type of lipid that forms the bilayer in cell membranes (12)
19. The aldehyde group in glucose is an example of this (10, 5)
20. Two monosaccharides joined together (12)
21. Element found in carbohydrates with a valency of four (6)

**Down**

1. Organic substance used in mammals for insulation (5)
3. Smallest particle that retains the properties of an element (4)
4. Building block of nucleic acids (10)
5. Found in lipids, these can be saturated or unsaturated (5, 4)
7. Substance containing only one type of atom (7)
9. Building block of proteins (5, 4)
10. Type of bond that holds water molecules together (8, 4)
11. Starch and cellulose are examples of this type of carbohydrate (14)
13. Bond holding glucose molecules together (10)
16. Most common element in cells (8)
18. Liquid that freezes from the top down (5)

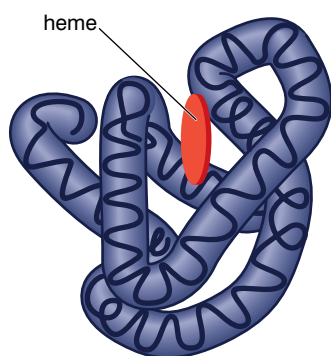
Contents	
Section	Learning competencies
3.1 Nature of enzymes (page 80)	<ul style="list-style-type: none"><li>• Define enzymes and explain the properties of enzymes.</li><li>• Explain how enzymes are named and then classify them according to their structure.</li><li>• Conduct an experiment to show the specificity of an enzyme.</li><li>• Appreciate the importance of enzymes in industries and local products.</li></ul>
3.2 Functions of enzymes (page 88)	<ul style="list-style-type: none"><li>• Explain how enzymes lower activation energy.</li><li>• Explain the mechanism of enzyme action.</li><li>• Discuss the action of apo- and coenzymes.</li><li>• Give examples of vitamins and minerals in food that act as cofactors.</li></ul>
3.3 Factors affecting the functions of enzymes (page 93)	<ul style="list-style-type: none"><li>• Explain factors that affect enzyme activity.</li><li>• Investigate the destruction of an enzyme by heat.</li><li>• Show how temperature, pH, substrate concentration and enzyme concentration affect enzyme activity.</li><li>• Explain allosteric regulation and feedback control mechanism of enzyme activity.</li><li>• Appreciate the role of enzymes in controlling our metabolic activities.</li></ul>

## KEY WORDS

**active site** *the part of an enzyme molecule that binds with its substrate so that the enzyme can catalyse the chemical reaction*

**substrate** *a substance upon which an enzyme acts in a biochemical reaction*

**enzyme–substrate complex** *the intermediate formed, temporarily, when an enzyme binds to its substrate*



$\beta$  polypeptide

**Figure 3.1** *The human lipase enzyme*

## 3.1 Nature of enzymes

By the end of this section you should be able to:

- Define enzymes and explain the properties of enzymes.
- Explain how enzymes are named and then classify them according to their structure.
- Conduct an experiment to show the specificity of an enzyme.
- Appreciate the importance of enzymes in industries and local products.

## What are enzyme molecules like?

First, all enzymes are globular proteins. We learned in unit 2 that globular proteins all have a unique tertiary structure, which gives them a unique shape. Figure 3.1 shows a model of the tertiary structure of the human lipase enzyme that hydrolyses lipids into fatty acids and glycerol.

You should be able to identify regions where there is:

- an  $\alpha$ -helix
- a  $\beta$ -pleated sheet
- no folding into a secondary structure.

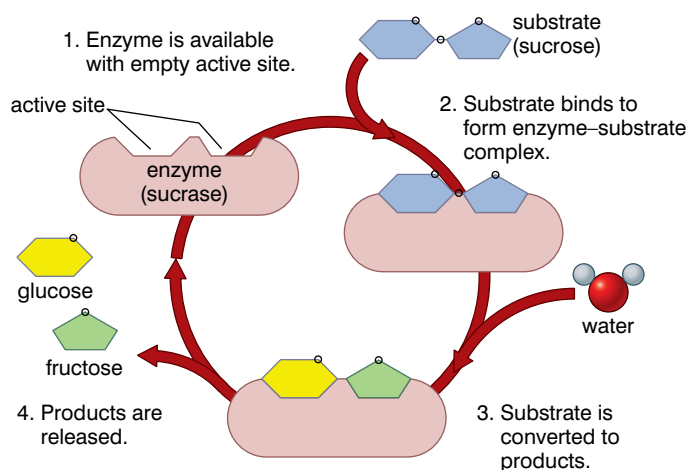
Second, within that very complex structure is a region called the **active site**. This is the part of the enzyme molecule that binds with its **substrate** so that the enzyme can catalyse the chemical reaction. The active site of an enzyme is shaped to allow:

- binding with a particular substrate and that substrate only, and
- binding in such a way that the reaction can take place requiring less energy than if the enzyme was not present.

We can use the example of the enzyme sucrase catalysing the hydrolysis of sucrose into glucose and fructose to illustrate this. The substrate for the enzyme is the molecule of sucrose. This binds with the active site to form an **enzyme–substrate complex**.

A molecule of water then reacts with the sucrose to hydrolyse the molecule into glucose and fructose. These are then released from the active site, which can then accept another molecule of sucrose. It is important to note that the enzyme is unaltered by the reaction.

This is shown in figure 3.2.



**Figure 3.2** *The hydrolysis of sucrose by sucrase*

We are now in a position where we can define more precisely what we mean when we are talking about an enzyme:

*An enzyme is a globular protein with a uniquely shaped active site; it acts as a biological catalyst for a specific reaction, but remains unaltered by the reaction.*

### KEY WORD

**catalyst** a substance that speeds up a chemical reaction and remains unchanged at the end of the reaction

### What are the properties of enzymes?

- They are all proteins.
- They are biological catalysts: they speed up a reaction without being used up, so they can be used over and over again.
- They are specific: they catalyse one reaction only.
- A small amount of enzyme can bring about a change in a large amount of its substrate.
- Enzymes are affected by pH and temperature. They can be destroyed by excessive heat. They are also affected by the concentration of their substrate and the presence of certain substances that act as inhibitors.

### What are catalysts?

A **catalyst** is a substance that speeds up a reaction; the reaction itself is unaltered. There is no overall change to:

- the nature of the products
- the energy change that takes place during the reaction
- the catalyst itself

Enzymes allow biochemical reactions inside cells to take place quickly, at a temperature that will not damage the structure of the cell.

### Why are enzymes specific?

This is also a function of the active site. Because of the conformation of the active site (the way in which it is shaped), only a certain substrate or combination of substrates can bind with it.

Because only one substrate (or substrate combination) can bind, there is only one possible reaction that can be catalysed. This is illustrated in figure 3.3.

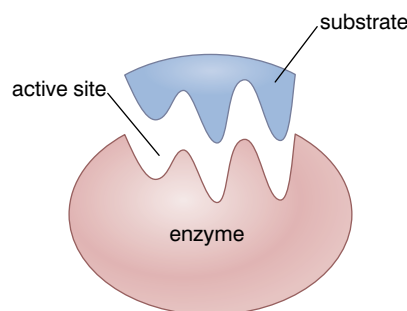
### How are enzymes affected by pH and by temperature?

Temperature affects enzyme action in two ways:

- a higher temperature gives the enzyme molecules (and their substrate molecules) more kinetic energy; they move around faster and form more enzyme–substrate complexes
- a higher temperature affects the chemical bonds holding the tertiary structure of the enzyme in place (particularly those in the active site); as more and more of these bonds break, the shape of the active site changes and it can no longer bind with its substrate

### DID YOU KNOW?

Not all biological catalysts are proteins. Recently, it has been shown that some RNA molecules can catalyse some biological reactions.



**Figure 3.3** An enzyme can only bind with one substrate because of the shape of its active site.

**Activity 3.1**

Make a poster which lists the four criteria for naming enzymes. Include a chart or key showing how you would classify the main types of enzymes (you will need to look at p83 before you can complete this activity).

pH affects the enzyme molecule in a similar way to high temperatures. A pH that is too low (too acid) or too high (too alkaline) will cause charges on the active site to alter and cause the active site to lose its conformation. The substrate cannot bind and so the reaction is no longer catalysed.

**How do we name and classify enzymes?****Common or working enzyme nomenclature (naming of enzymes)**

Table 3.1 gives some examples of enzymes and the reactions they catalyse.

**Table 3.1** Examples of enzymes and the reactions they catalyse

Name of enzyme	Reaction catalysed
Lipase	Hydrolysis of lipids
ATPase	Hydrolysis of ATP
Succinate dehydrogenase	Removal of hydrogen ions from succinate (during respiration)
DNA polymerase	Joining of nucleotides to form DNA
Pepsin	Digestion of proteins in the stomachs of mammals

Different enzymes are named in different ways.

- Most commonly enzymes are named by adding 'ase' to part of the name of the substrate. For example, *lipase* (lipid hydrolysing enzyme), *sucrase* (sucrose hydrolysing enzyme).
- Sometimes the enzymes are named on the basis of the reaction that they catalyse. For example, *polymerase* (aids in polymerisation – joining similar units together), *dehydrogenase* (removal of hydrogen atoms or ions).
- Some enzymes have been named based on the source from which they were first identified. For example, *papayin* from papaya. Others are named according to where they act. For example, *intestinal* protease acts on proteins in the intestine.
- The names of some enzymes end with 'in', indicating that they are basically proteins. For example, *pepsin*, *trypsin*, etc. These enzymes usually have alternative names that tell you rather more about them. For example, the alternative name for pepsin is gastric protease. This tells you that it acts on proteins and it does so in the stomach.

Because of the varied ways in which enzymes had been named, biologists at the **Enzyme Commission** decided to produce a systematic way of naming enzymes, based on the ways in which the enzymes act. To appreciate this, we must first look at how enzymes are classified.

**KEY WORD**

**Enzyme Commission** *body set up to produce a systematic way of naming enzymes*

## Enzyme classification and the systematic nomenclature of enzymes

Enzymes are generally classified on the basis of the type of reactions that they catalyse. Six groups of enzymes can be recognised on this basis. Table 3.2 lists these groups along with examples.

**Table 3.2** Classification of enzymes

Class	Reaction catalysed	Examples
1. Oxidoreductases	Transfer of hydrogen and oxygen atoms or electrons from one substrate to another	Dehydrogenases Oxidases
2. Transferases	Transfer of a specific group (a phosphate or methyl, etc.) from one substrate to another	Transaminase Kinases
3. Hydrolases	Hydrolysis of a substrate	Esterases Digestive enzymes
4. Isomerases	Change of the molecular form of the substrate	Phosphohexoisomerase Fumerase
5. Lyases	Nonhydrolytic removal of a group or addition of a group to a substrate	Decarboxylases Aldolases
6. Ligases (Synthetases)	Joining of two molecules by the formation of new bonds	Citric acid synthetase

Each class of enzymes contains several different, but related, subclasses. Each subclass is further divided into sub-subclasses. Within the sub-subclasses, each enzyme has a number.

So, in the systematic naming of enzymes, an enzyme will have a 'name' such as EC 3.4.11.1. Each part of the description tells us something about the enzyme:

- EC stands for Enzyme Commission
- the first number shows to which of the six main classes the enzyme belongs
- the second figure indicates a subclass
- the third figure gives a sub-subclass
- the fourth figure is the serial number of the enzyme in its sub-subclass.

Enzyme EC 3.4.11.1 is:

- a hydrolase – all the enzymes in class 3 hydrolyse some kind of bond
- a peptidase – all the enzymes in subclass 4 of class 3 are peptidases and hydrolyse peptide bonds
- an amino-peptidase – all the enzymes in sub-subclass 11 of subclass 4 are amino-peptidases; they hydrolyse peptide bonds at the amino end of a polypeptide chain
- leucyl-amino-peptidase – this particular amino-peptidase is number 1 of this sub-subclass



**Figure 3.4** Yeast cells

### Activity 3.2: Library search

If you have access to the internet, you could visit site: [www.chem.qmul.ac.uk/iubmb/enzyme/](http://www.chem.qmul.ac.uk/iubmb/enzyme/) and find out more about the naming of enzymes. What is enzyme 1.1.1.1?

### What do enzymes do for you?

We have been using enzymes for thousands of years – although the people who used them then didn't know quite what they were using! Unknowingly, they used enzymes (in yeast) to make bread and beer. These are almost certainly the first uses of 'enzyme technology'.

Yeast is a unicellular fungus that ferments carbohydrates to produce carbon dioxide and alcohol. The enzymes in yeast control the reactions of fermentation. Figure 3.4 shows some yeast cells.



### DID YOU KNOW?

#### How long people have been brewing beer?

The oldest proven records of brewing are about 6000 years old in the ancient country of Sumeria, in the Middle East. A document 4000 years old is a Sumerian 'Hymn to Ninkasi', who was the goddess of brewing! The 'hymn' is also a recipe for making beer.

Of course, these people did not know they were using enzymes. They did not know at first that they were using yeast! But as time progressed people found that it was the yeast that fermented carbohydrates into alcohol. Now we know that several enzymes are involved in the brewing process and can control it much more efficiently.

**Figure 3.5** An ancient Egyptian tomb model showing a woman brewing beer



**Figure 3.6** Injera

We still use yeast to brew alcoholic drinks, such as tella, and to bake breads, such as injera. Both these Ethiopian products are often made at home, as well as professionally.

When dough is baked to produce the bread, the tiny amount of alcohol formed is lost and the carbon dioxide expands to make the dough 'rise' to form a loaf of bread. When beer is brewed, it is the carbon dioxide that is lost and the alcohol remains!

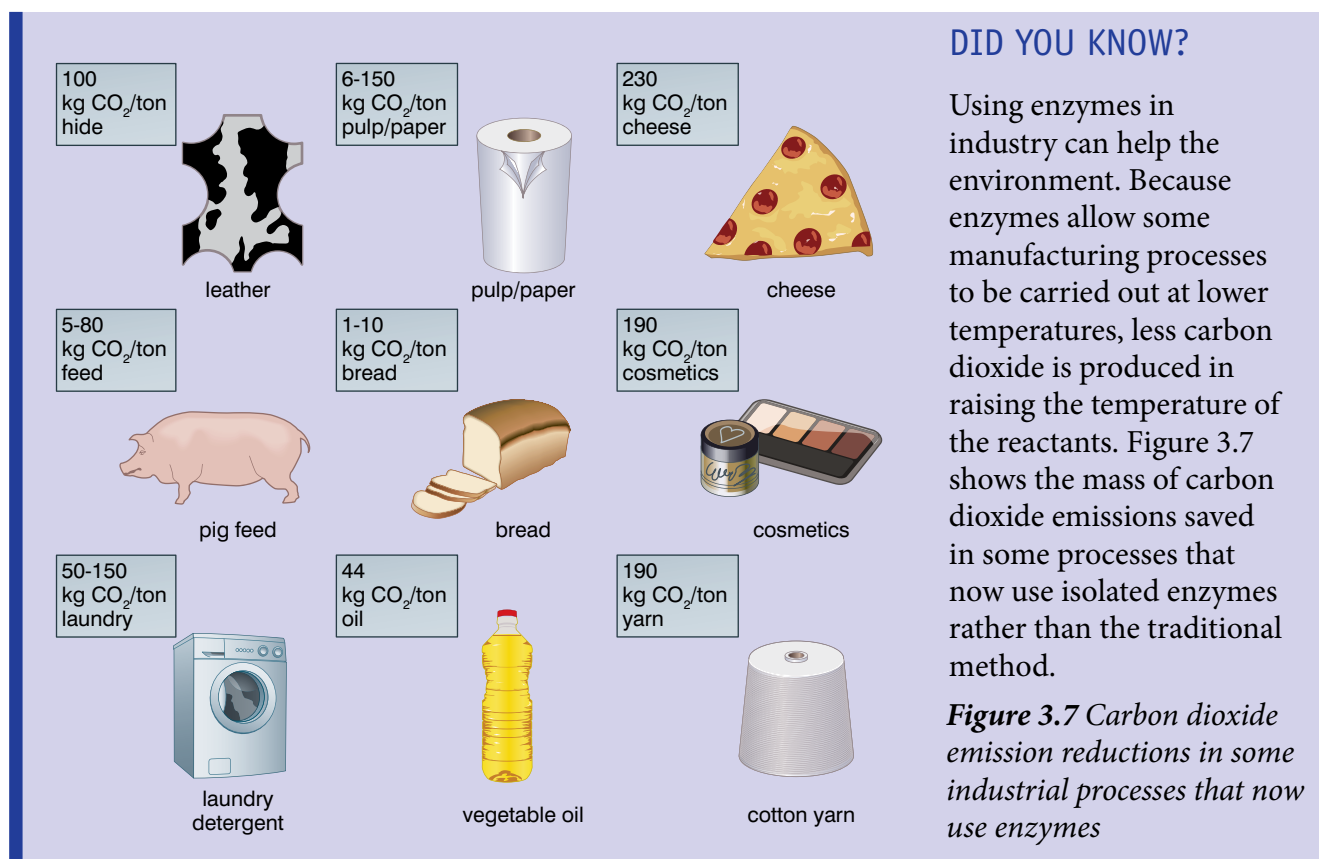
However, enzyme technology is now very big business. Enzymes are used in many industries. They are used to produce washing powders – the enzymes in the washing powders digest the stains in the clothes. 'Stone-washed' denim jeans are now given their stone-washed look by the action of enzymes. Table 3.3 shows just a few of the areas where enzyme technology is used.



**Table 3.3** Some industrial uses of enzyme technology

Sector	Application area	Benefits
Dairy	<ul style="list-style-type: none"> <li>Biochymosin to produce cheese</li> <li>Lactase to produce lactose-free milk</li> </ul>	<ul style="list-style-type: none"> <li>Supplies of natural rennet from calves livers are limited</li> <li>Lactose-intolerant people suffer fewer cramps</li> </ul>
Detergents	<ul style="list-style-type: none"> <li>Use of proteases, lipases and amylases in biological washing powders</li> <li>Use of proteases and amylases in dishwasher detergents</li> </ul>	<ul style="list-style-type: none"> <li>Many biological stains are removed efficiently at low temperatures (saving energy)</li> <li>Remove food particles at lower temperatures and require fewer bleaching products to be added</li> </ul>
Textiles	<ul style="list-style-type: none"> <li>Proteases to remove hair and lipases to degrease animal hides</li> <li>Use of cellulase to 'bio-polish' cotton fabrics</li> <li>Use of cellulase to 'bio-stone' denim</li> </ul>	<ul style="list-style-type: none"> <li>Process is carried out much quicker than by traditional methods</li> <li>Produces a smoother and glossier finish</li> <li>The enzyme gives the 'stone-washed' effect much more easily</li> </ul>
Food processing	<ul style="list-style-type: none"> <li>Pectinase to process fruit juice</li> <li>Inverase to produce liquid-centre chocolates</li> </ul>	<ul style="list-style-type: none"> <li>Clarifies fruit juice</li> <li>Sucrose paste in the chocolate is made liquid by injection of the enzyme</li> </ul>
Pulp and paper	<ul style="list-style-type: none"> <li>Amylases used in starch conversion</li> <li>Use of xylanase enzymes in pre-bleaching the pulp</li> <li>Use of esterases in control of 'stickies' (glues introduced during paper recycling)</li> </ul>	<ul style="list-style-type: none"> <li>Reduces the quantity of starch in the paper and improves quality</li> <li>Produces a whiter paper</li> <li>Stickies would otherwise clog the machinery and reduce the quality of the paper</li> </ul>
Medicine	<ul style="list-style-type: none"> <li>Glucose oxidase in clinistix strips, tests for glucose</li> <li>Liver enzymes</li> <li>Pulmozyme to treat cystic fibrosis</li> </ul>	<ul style="list-style-type: none"> <li>Allows easy diagnosis of diabetes by testing urine</li> <li>Testing for high levels of these in the blood confirms liver damage</li> <li>Reduces viscosity (stickiness) of mucus</li> </ul>
Pharmaceutical	<ul style="list-style-type: none"> <li>Streptokinase to dissolve clots of heart-attack patients</li> <li>Production of abacavir sulphate is controlled by enzymes</li> </ul>	<ul style="list-style-type: none"> <li>Restores blood supply to area of heart muscle</li> <li>Abacavir sulphate is an important anti-AIDS drug</li> </ul>

One of the appeals of using enzymes in industry is that they allow the reactions involved in the processes to be carried out at much lower temperatures. This means less energy (and therefore less money) is spent on heating the reactants. Because less heating is required, less carbon dioxide is produced and this can benefit the environment as carbon dioxide is a greenhouse gas and its accumulation in the atmosphere can lead to global warming.



### DID YOU KNOW?

Using enzymes in industry can help the environment. Because enzymes allow some manufacturing processes to be carried out at lower temperatures, less carbon dioxide is produced in raising the temperature of the reactants. Figure 3.7 shows the mass of carbon dioxide emissions saved in some processes that now use isolated enzymes rather than the traditional method.

**Figure 3.7** Carbon dioxide emission reductions in some industrial processes that now use enzymes

### Activity 3.3: Discussion

#### The importance of enzymes in local manufacturing

As you have seen from the material presented in this book, some enzymes have been used for many hundreds of years in manufacturing processes and the number being used is increasing all the time. In this activity, you will discuss the importance of enzymes in these local processes. You might bear in mind:

- the importance of enzymes as catalysts in the processes
- whether or not there are other options to using enzymes in the processes that might be more cost-effective

The activity will follow the following procedure:

Your teacher will describe some of the uses of enzymes in the manufacture of products in your locality.

Your teacher will then ask you for your opinions as to how crucial you think the role of enzymes is in these processes. You may then make your point of view but, during this stage, it is important that:

- you do not interrupt anyone else; they also have the right to put their point of view
- you only put your point of view when your teacher allows you to – the discussion cannot degenerate into a row!

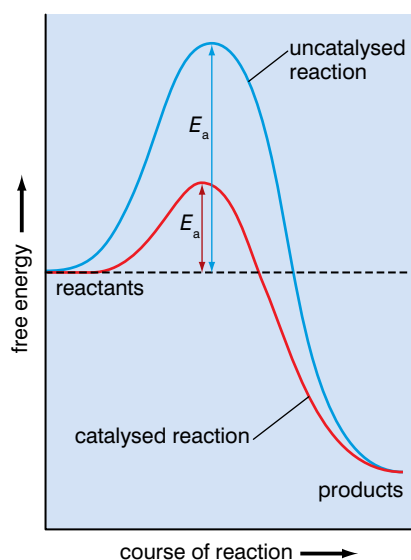
At the end of the discussion, your teacher will summarise the views of the class.

You will write a summary of the main views held by different people in the group.

## Review questions

Choose the correct answer from A to D.

- All enzymes are:
  - globular proteins that digest large molecules
  - globular proteins that catalyse reactions
  - fibrous proteins that catalyse reactions
  - fibrous proteins that digest large molecules
- Enzymes are specific because:
  - they are globular proteins
  - they are affected by temperature and pH
  - their tertiary structure gives them a uniquely shaped active site
  - they may have cofactors
- The shape of an enzyme's active site and its substrate are:
  - complementary
  - the same
  - similar
  - related
- Catalysts:
  - speed up a reaction and are used up in the process
  - slow down a reaction and are used up in the process
  - slow down a reaction and are not used up in the process
  - speed up a reaction and are not used up in the process
- The name of an enzyme often ends in:
  - ase
  - ese
  - ise
  - ose
- Some enzymes' names are derived from their substrate. An example of this is:
  - pepsin
  - papayin
  - nuclease
  - amylase
- How many classes of enzymes are there in the Enzyme Commission classification?
  - 3
  - 4
  - 5
  - 6
- Which of the following is NOT a reason why enzymes are often used in industrial processes?
  - they allow reactions to be carried out at lower temperatures
  - they reduce heating costs
  - more energy is used and so more carbon dioxide is produced during the process
  - less energy is used and so less carbon dioxide is produced during the processes
- An environmental benefit of using enzymes in industrial processes is that it can:
  - reduce use of paper in packaging the product
  - reduce carbon dioxide emissions
  - increase purity of the product
  - reduce the costs involved
- One advantage of the Enzyme Commission systematic naming of enzymes is:
  - all enzymes are 'named' in the same way
  - biologists from all countries can understand the 'name' equally
  - no local knowledge is necessary to understand the name
  - all of the above



**Figure 3.8** Activation energy for an uncatalysed reaction and the same reaction with a catalyst

## 3.2 Functions of enzymes

By the end of this section you should be able to:

- Explain how enzymes lower activation energy.
- Explain the mechanism of enzyme action.
- Discuss the action of apo- and coenzymes.
- Give examples of vitamins and minerals in food that act as cofactors.

### How do enzymes act as catalysts?

Catalysts speed up chemical reactions. In order for molecules to react, they must have sufficient energy. This energy to start off the reaction is called **activation energy** (or  $E_a$ ). Imagine a reaction in which substance A reacts with substance B to form substance AB. We can write an equation for this as:  $A + B \rightarrow AB$

However, this does not tell the whole story. The equation gives only the reactants (starting materials) and the products. It does not show how the energy changes as the reaction takes place.

The reactant must ‘climb an activation energy hill’ before anything happens. Under normal conditions, very few molecules of A and B have sufficient kinetic energy to ‘climb the activation energy hill’, so the reaction proceeds slowly. A catalyst lowers the activation energy required for the reaction. More reactant molecules can meet this lower energy requirement and so the reaction proceeds more quickly. Because the enzyme molecule is unaltered by the reaction, it can be used over and over, and so a small amount of enzyme can affect a large amount of substrate. This is shown in figure 3.8.

### How do enzymes lower activation energy?

There are two models of enzyme action; the **lock-and-key model**, first proposed in 1894 by a German biochemist named Fischer and the **induced-fit model**, proposed in 1958 by Koshland. Both of these models suggest that the enzyme catalyses the reaction by lowering the activation energy. However, they differ in the way that they explain how this happens. In particular, they differ in explaining how the substrate binds to the active site of the enzyme.

#### The lock-and-key model

This model proposes that the shapes of the substrate molecules are *complementary* to that of the active site, rather like the shape of a key is complementary to that of the lock it fits. A useful way of thinking of complementary shapes is to think of an egg sitting in an egg cup. The egg can sit inside the egg cup because the shapes are complementary. One egg cannot sit inside another egg because the shapes are the same.

#### KEY WORDS

**activation energy** *the energy required to start off a chemical reaction*

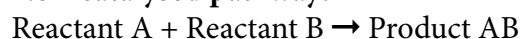
**lock-and-key model** *proposes that the shapes of the substrate molecules are complementary to that of the active site*

**induced-fit model** *the active site and substrate do not complement each other but the binding of substrate molecules produces a change in shape in the active site, allowing the substrate to fit the active site*

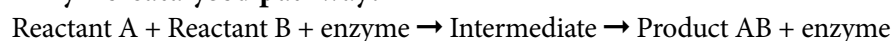
The complementary substrate molecule binds with the active site of the enzyme to form the enzyme–substrate complex. The complex causes the reactants to enter a transition state in which the activation energy of the reaction is lowered. The reaction takes place and the products formed are released. The lock-and-key model of enzyme action suggests that the enzyme lowers the activation energy by providing an alternative pathway for the reaction.

For example:

#### Non-catalysed pathway:



#### Enzyme-catalysed pathway:



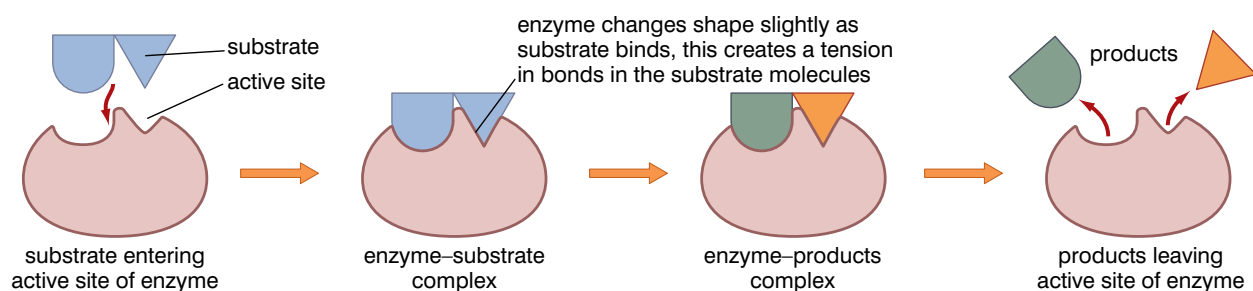
This model sees the enzyme–substrate complex as the intermediate, which is part of a pathway that requires less energy than the normal pathway. However, a weakness of this model is that it does not explain how the intermediate reduces activation energy.

### The induced-fit model

This model suggests that the active site and the substrate aren't naturally complementary in shape, but the binding of substrate molecules produces a conformational change (change in shape) in the active site. This allows the substrate and active site to bind fully. The conformational change also puts the substrate molecules under tension, so they enter a 'transition state' and are able to react because of the lowered activation energy. In the transition state, bonds in the reactants are put under strain and break more easily and rejoin with other bonds to form the products. The products formed leave the active site. This is shown in figure 3.11.

Most biologists now prefer the induced-fit model over the lock-and-key model as it explains other properties of enzymes, such as enzyme inhibition, in a more complete manner than the lock-and-key model.

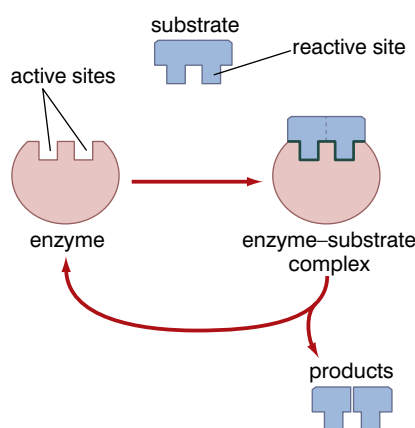
The rate of a chemical reaction is the rate at which reactants are converted into products. In the case of an enzyme-controlled reaction, this is determined by how many molecules of substrate bind with enzyme molecules to form enzyme–substrate complexes. The number of molecules of reactants that form enzyme–substrate complexes with each molecule of an enzyme, per second, is the **turnover rate** of the enzyme.



**Figure 3.11** The induced-fit model of enzyme action



**Figure 3.9** Complementary shapes



**Figure 3.10** The lock-and-key model of enzyme action

#### KEY WORD

**turnover rate** the number of molecules of reactants that form enzyme–substrate complexes with each molecule of an enzyme, per second

**DID YOU KNOW?****Just how much faster enzyme-catalysed reactions proceed**

Table 3.4 shows how much faster reactions proceed with the enzymes than without the enzymes.

**Table 3.4** The rate enhancement of some enzymes

Enzyme	Rate enhancement
OMP decarboxylase	$1.4 \times 10^{17}$
Staphylococcal nuclease	$5.6 \times 10^{14}$
Adenosine deaminase	$2.1 \times 10^{12}$
AMP nucleosidase	$6.0 \times 10^{12}$
Cytidine deaminase	$1.2 \times 10^{12}$
Phosphotriesterase	$2.8 \times 10^{11}$
Carboxypeptidase A	$1.9 \times 10^{17}$
Ketosteroid isomerase	$3.9 \times 10^{17}$
Triosephosphate isomerase	$1.0 \times 10^9$
Chorismate mutase	$1.9 \times 10^6$
Carbonic anhydrase	$7.7 \times 10^6$
Cyclophilin, human	$4.6 \times 10^5$

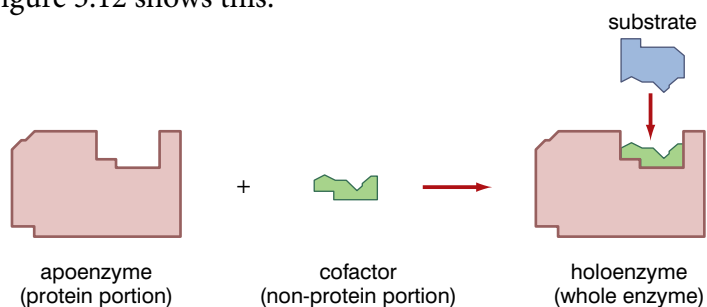
**Why do some enzymes need cofactors?**

Sometimes an active enzyme isn't just a single molecule, but is made from two molecules, neither of which has enzymic activity without the other. The two parts are the apoenzyme and the cofactor. We can define these in the following way:

**Apoenzyme** – a protein that combines with a cofactor, to form an active enzyme. The protein is inactive on its own.

**Cofactor** – a small non-protein particle essential for the activity of some enzymes. The cofactor combines with the apoenzyme to produce an active enzyme.

Where an active enzyme molecule comprises an apoenzyme and a cofactor, the whole is sometimes referred to as the **holoenzyme**. Figure 3.12 shows this.



**Figure 3.12** The apoenzyme and the cofactor make the holoenzyme.

Cofactors include:

- coenzymes
- mineral ions

**Coenzymes** are organic molecules and many are derived from vitamins. They bind with the enzyme to give catalytic activity.

Table 3.5 shows some common co enzymes, the vitamins they are derived from, the enzyme with which they bind, and their functions.

**Table 3.5** Common coenzymes and their functions

Coenzyme	Vitamin	Enzyme	Function
Nicotinamide adenine dinucleotide (NAD)	Niacin	Oxidoreductase in respiration	Oxidation or hydrogen transfer in respiration
Flavin adenine dinucleotide (FAD)	Riboflavin	Oxidoreductase in respiration	Oxidation or hydrogen transfer in respiration

Some enzymes can only function in the presence of certain mineral ions. These bind loosely with the enzyme to give it its catalytic activity. Table 3.6 shows some examples of enzymes that require mineral ions as cofactors.

**Table 3.6** Enzymes that require mineral ions as cofactors

Enzyme	Mineral ion	Function
Carbonic anhydrase	Zinc ions ( $Zn^{++}$ )	Causes $CO_2$ to react with water to form hydrogen carbonate
Alcohol dehydrogenase	Zinc ions ( $Zn^{++}$ )	Oxidises alcohol
Cytochrome oxidase	Copper ions ( $Cu^{++}$ or $Cu^+$ )	Transfers electrons to oxygen during respiration

### Activity 3.4: Field visit

#### Field visit to study the use of enzymes by local manufacturers

You may be able to visit a nearby manufacturing plant that uses enzymes in some of its processes. If this is possible you should:

- make careful notes when you are there about:
- the processes themselves
- the role of enzymes in these processes
- write a report on your return that describes how important the use of enzymes is in this particular manufacturing plant

## Review questions

Choose the correct answer from A to D.

- Enzymes speed up biological reactions by:
  - reducing the kinetic energy of the reacting molecules
  - reducing the activation energy of the reaction
  - increasing activation energy of the reaction
  - increasing the kinetic energy of the reacting molecules
- Which of the following statements about a lock and key model of enzyme action are not true?
  - the substrate and the active site bind because they have shapes that fit together like a key fits in a lock
  - the substrate and the active site have complementary 3-D shapes
  - nothing can interfere with the way the substrate and the active site bind together
  - high temperatures stop enzymes working as they denature the protein and change the shape of the active site

**Activity 3.5**

Design a 3-dimensional model to show how an enzyme works. You can plan to use a variety of resources from a carved fruit to modelling clay, from papier mache to paper and card. You may have the opportunity to actually make your model and display it to the rest of the class.

3. The induced-fit model of enzyme action suggests that, when enzyme and substrate bind, there is a conformational change in:
  - A the substrate
  - B the active site
  - C both substrate and active site
  - D neither substrate nor active site
4. An apoenzyme is:
  - A a protein with enzymic activity
  - B a non-protein with enzymic activity
  - C a non-protein with no enzymic activity
  - D a protein with no enzymic activity
5. Which of the following does not act as a cofactor to an enzyme?
  - A niacin
  - B copper ions
  - C pepsin
  - D riboflavin
6. A coenzyme is:
  - A an organic molecule that binds tightly with the apoenzyme
  - B an organic molecule that binds loosely with the apoenzyme
  - C an inorganic molecule that binds loosely with the apoenzyme
  - D an inorganic molecule that binds tightly with the apoenzyme
7. Mineral ions needed for enzyme activity:
  - A bind tightly with the apoenzyme
  - B bind loosely with the apoenzyme
  - C bind loosely with the coenzyme
  - D bind tightly with the coenzyme
8. Many coenzymes are derived from:
  - A vitamins
  - B hormones
  - C lipids
  - D proteins
9. The turnover rate of an enzyme is:
  - A the number of enzyme molecules used per second
  - B the number of product molecules formed per second
  - C the number of reactant molecules used per second
  - D all of the above
10. According to the induced-fit model of enzyme action, reacting molecules enter a transition state in which:
  - A reacting molecules assume a complementary shape
  - B apoenzyme and cofactor assume a complementary shape
  - C bonds in reacting molecules are put under tension
  - D bonds in the apoenzyme and coenzyme are put under tension



### 3.3 Factors affecting the functions of enzymes

By the end of this section you should be able to:

- Explain factors that affect enzyme activity.
- Investigate the destruction of an enzyme by heat.
- Show how temperature, pH, substrate concentration and enzyme concentration affect enzyme activity.
- Explain allosteric regulation and the feedback control mechanism of enzyme activity.
- Appreciate the role of enzymes in controlling our metabolic activities.

The turnover rate and, therefore, the activity of the enzyme are influenced by a number of external factors, including:

- temperature
- pH
- substrate concentration
- the presence of inhibitors

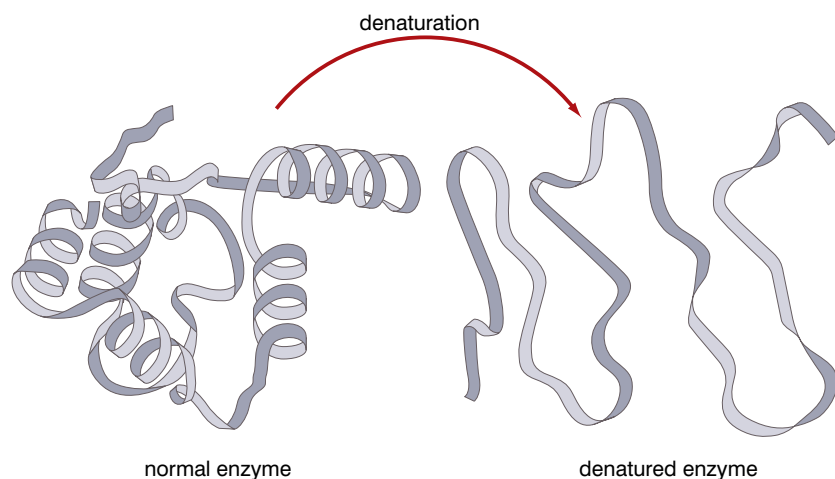
#### How hot must it be?

When the temperature is raised, particles are given more kinetic energy. This has two main effects:

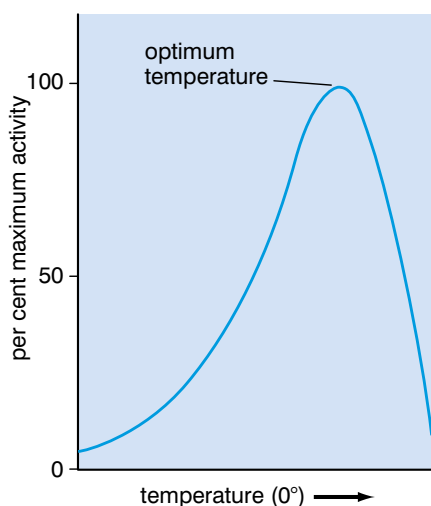
- 'Free' particles move around more quickly. This increases the probability that a substrate particle will collide with an enzyme molecule.
- Particles within a molecule vibrate more energetically. This puts strain on the bonds that hold the atoms in place. Bonds begin to break and, in the case of an enzyme, the shape of the molecule, and the active site in particular, begin to change. The enzyme begins to lose its tertiary structure (remember it is a protein) and **denature**. Figure 3.13 shows this.

#### KEY WORD

**denature** *the alteration of the tertiary structure of a protein; in living cells this is reversible*



**Figure 3.13** How an enzyme denatures



**Figure 3.14** The effect of temperature on enzyme activity

### DID YOU KNOW?

#### Optimum temperatures

Enzymes do not all have the same optimum temperature; they are adapted to work most efficiently within the organism in which they are found. For example, the optimum temperature for enzymes:

- in human beings is around 37 °C (normal body temperature)
- in plants growing in the Arctic may be less than 5 °C
- in bacteria that live in hot springs (thermophilic bacteria) may be over 90 °C.

The activity of an enzyme at a given temperature is a balance between these two effects. If the raised temperature results in little denaturation but a greatly increased number of collisions, the activity of the enzyme will increase. If the higher temperature causes significant denaturation then, despite the extra collisions, the activity of the enzyme will probably decrease. The temperature at which the two effects just balance each other is the **optimum temperature** for that enzyme. Any further increase in temperature will cause increased denaturation that will outweigh the effects of extra collisions. A decrease in temperature means that fewer collisions will occur. Figure 3.14 shows this.

Note that the graph is not symmetrical. Above the optimum temperature, the enzyme denatures very quickly to the point at which the shape of the active site has changed so much that an enzyme–substrate complex cannot form. At this point the reaction rate is zero.

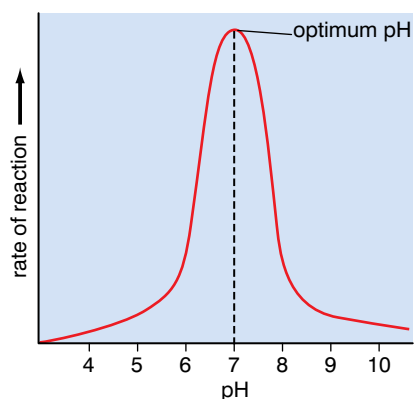
### How acidic must it be?

The **pH scale** is a measure of the hydrogen ion concentration of a solution or other liquid system. The pH scale ranges from 0 to 14. Solutions with a pH of less than 7 are acidic, those with a pH of more than 7 are alkaline and a solution with a pH of exactly 7 is neutral.

The majority of enzymes in most mammals function most efficiently within the pH range 6.0–8.0, although the optimum pH of pepsin (an enzyme found in the stomach) is between pH 1.0 and pH 3.0. Significant changes in pH can affect an enzyme molecule by:

- breaking ionic bonds that hold the tertiary structure in place; this leads to denaturation of the enzyme molecule
- altering the charge on some of the amino acids that form the active site; this makes it more difficult for substrate molecules to bind

These effects occur if the pH becomes either more acidic or more alkaline. Figure 3.15 shows this effect.



**Figure 3.15** The effect of pH on enzyme activity

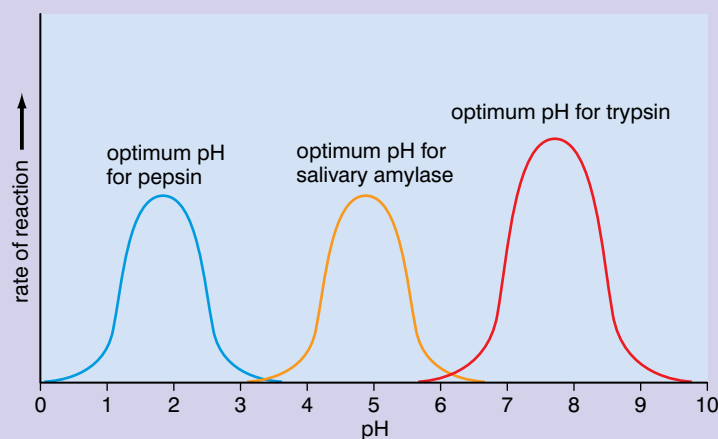
### DID YOU KNOW?

#### About pH

The pH scale of acidity/alkalinity is an inverse logarithmic scale! Each pH unit represents a tenfold change in hydrogen ion ( $H^+$ ) concentration. pH 0 represents the highest  $H^+$  concentration and is the most acid. A pH 1.0 solution has one-tenth (0.1) of this  $H^+$  concentration; a pH 4 solution has one ten-thousandth (0.0001). pH 14 represents the lowest  $H^+$  concentration and is the most alkaline. pH 7 is neutral.

**DID YOU KNOW?****About the pH in your gut**

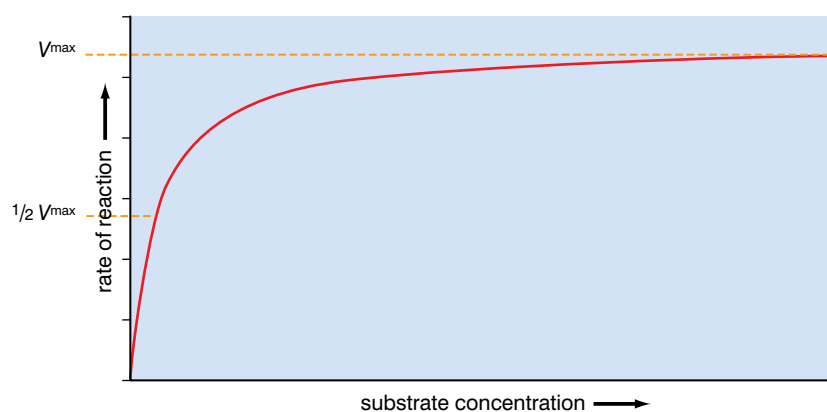
The pH of the intestinal tract of humans changes from one region to the next. The pH in the mouth varies from being slightly alkaline (pH 7.5) to quite acidic (pH 5.0) depending on whether or not we have eaten and also what we have eaten. The pH in the stomach can be as low as pH 1.5, whereas the pH of the small intestine is slightly alkaline at pH 7.5. Digestive enzymes from the different regions have optimum pHs that reflect the region in which they are secreted. Figure 3.16 shows the optimum pHs of salivary amylase (mouth), pepsin (stomach) and trypsin (small intestine).



**Figure 3.16** The optimum pHs of some human digestive enzymes

**Does the concentration of the substrate matter?**

The activity of an enzyme depends on the number of substrate molecules per second that bind to form enzyme–substrate complexes. So the number of substrate molecules present must have an effect. A small number of substrate molecules means few collisions and so only a few enzyme–substrate complexes form. Increasing the concentration of the substrate means more collisions and more enzyme–substrate complexes. So, the overall rate of reaction is increased. Eventually, because of the high substrate concentration, each enzyme molecule could be working at maximum turnover – that is, each active site is binding with substrate molecules all the time and there is no ‘spare capacity’ in the system. Increasing the substrate concentration beyond this point will have no effect on the activity of the enzyme because all the active sites are occupied all the time. Figure 3.17 shows this effect.



**Figure 3.17** The effect of substrate concentration on enzyme activity.  $V_{max}$  is the maximum rate of enzyme action.

**KEY WORDS**

**optimum temperature**  
temperature at which an enzyme works most efficiently

**pH scale** measure of the hydrogen ion concentration of a solution

**KEY IDEA**

Think about what will happen to the concentration of substrate molecules as an enzyme-controlled reaction takes place. As the reaction proceeds, more and more of the substrate molecules react, so there will be fewer remaining. The concentration of the substrate will decrease. With fewer substrate molecules left, the number of collisions per second between enzyme and substrate will also decrease, and the rate of reaction will slow down. This is because the turnover rate of each enzyme molecule decreases with time.

### How much enzyme should there be?

Assuming a constant large supply of substrate molecules, each enzyme molecule will work at maximum turnover. Therefore, the reaction rate will be directly proportional to the number of enzyme molecules – the concentration of the enzyme. Increasing the concentration will increase the reaction rate.

*However*, increasing the concentration of the enzyme will not increase the activity of the enzyme. Each enzyme molecule will be working at maximum turnover, so the activity of the enzyme is likely to remain constant.

### Activity 3.6: How can we measure the rate of an enzyme-controlled reaction?

We can do this in one of two ways. We can:

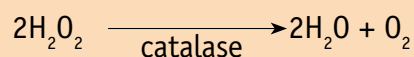
- measure the rate at which the substrate is used up, or
- measure the rate at which the product is formed.

Usually, it is more convenient to do the latter – measure the rate at which product is formed.

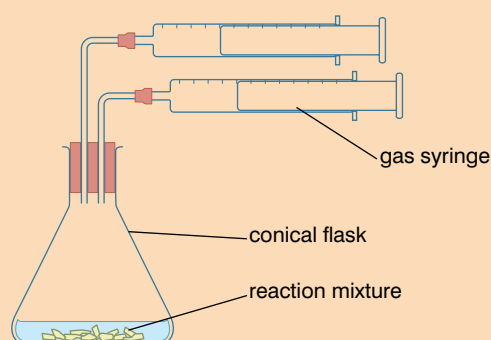
The enzyme catalase is commonly used in these sorts of investigations. This is because it is found in almost all cells and there are many readily available sources that contain significant amounts of catalase. These include:

- yeast
- liver
- potato

Catalase catalyses the decomposition of hydrogen peroxide to water and oxygen. The equation for the reaction is:



Because oxygen is a gas, the volume of oxygen collected in a certain time is a measure of how fast the reaction is proceeding. There are several ways of carrying out the investigation. One of these is shown in figure 3.18. This investigation uses potato, but it could just as easily be carried out with yeast or pieces of liver.



**Figure 3.18** Apparatus set-up

#### You will also need:

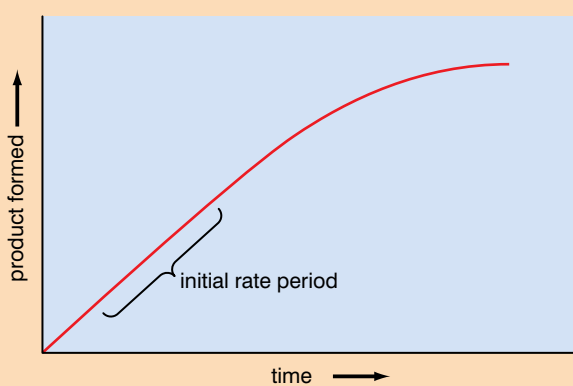
- a potato
- access to a balance
- 10 volume hydrogen peroxide solution (safety note: this is an oxidising agent, take care)
- a scalpel and a tile on which to cut the potato
- a stopwatch

#### The experiment is carried out as follows:

1. Peel a potato and chop into small pieces (less than 1 cm square).
2. Weigh out 10 g of the potato and place it in the conical flask.
3. Attach the gas syringe (you will need to support it with a clamp and stand).
4. Make sure that the gas syringe:
  - is horizontal
  - reads zero

5. Draw 20 cm<sup>3</sup> hydrogen peroxide into the second syringe and attach it to the conical flask.
6. Check again that all seals are tight, the gas syringe reads zero and is horizontal.
7. Add all the hydrogen peroxide solution to the potato quickly and start the stopwatch.
8. Record the volume of gas collected in the gas syringe every minute for ten minutes.

Now that you have a set of results, you can plot them as a graph. You may well end up with a graph that looks like the one below:



**Figure 3.19** A graph of the results.

Notice that the line is starting to level off (yours may have completely levelled off). This is because as the reaction proceeds, substrate is used up, fewer enzyme substrate complexes form and the reaction rate slows down. Not as much oxygen is formed per minute as a result.

This procedure is a very basic one and there are a number of reasons why the results obtained might not be reliable. These include:

- We did not control the temperature; it might have increased or decreased during the investigation, speeding up the reaction or slowing it down.
- We did not control the pH of the reaction mixture; it too might have increased or decreased during the investigation, speeding up the reaction or slowing it down.
- We only carried out the investigation once; we may have obtained an anomalous (freak) result.

However, we did control:

- The concentration of the substrate (we used 10 volume hydrogen peroxide).
- The concentration of the enzyme (we used a specific mass of potato).

We can improve our investigation fairly easily, as shown in table 3.7.

**Table 3.7** Improving the investigation

Factor controlled	How controlled	Note
Temperature	Use of water bath at the required temperature	Stand the potato pieces in the conical flask and hydrogen peroxide in the water bath separately for 10 minutes. This is called equilibration.
pH	Use of buffer solutions at required pH	Buffer solutions resist changes in pH and maintain a more or less constant pH. Add the buffer solution to the potato pieces at the start.
Repeats	Carry out the experiment three or five times	Carrying out the experiment more than once allows us to spot anomalous results and eliminate them. This is easier if you have an odd number of results.

We can use this basic experiment, with the improvements, to investigate how the different factors affect the rate of enzyme action. Before we do, however, we must be quite clear about what we are trying to find out.

**Reminder from Unit 1**

- The factor that you change is the independent variable (IV).
- The factor that you record as the results is the dependent variable (DV).

**Activity 3.7**

Plan an investigation into the effect of temperature on the rate of an enzyme controlled reaction such as the breakdown of starch by the enzyme amylase in saliva or the breakdown of hydrogen peroxide by the enzyme catalase in potato or liver. Explain how you would vary the temperature of the reacting mixture and suggest what results you would expect to see.

**KEY IDEA**

*The 'rate of enzyme action', like any rate, means 'how much per unit of time'. We cannot just say 12 cm<sup>3</sup> oxygen. We must convert this to volume per minute, or volume per second. Then we have a rate.*

*It is also best if we can compare the rates of enzyme action when they are working to maximum or near maximum capacity for the conditions. So, before we proceed to the main investigations, we should:*

- *carry out our improved basic experiment three times*
- *plot the graphs of our results*
- *determine the point on each where the graph starts to level*
- *take an average of these times*

*This is the time we will use for our main investigations.*

*You are now in a position to use this procedure to design your own investigations into:*

- *the effect of temperature on enzyme activity*
- *the effect of pH on enzyme activity*
- *the effect of substrate concentration on enzyme activity*

*When you are investigating one factor, then all the others need to be controlled – kept constant – so that they cannot influence the results. If you were investigating the effect of temperature then pH, substrate concentration and enzyme concentration would need to be controlled, as would the duration of the experiment.*

For each of your investigations, you should think about each of the following:

- How will I change the independent variable?
- How will I measure the dependent variable?
- What other factors need to be controlled?
- How will I control them?
- How many different values of the IV shall I use? Usually five is the minimum requirement.
- What values shall I use? These need to be reasonably spaced, for example, temperatures of 20 °C, 30 °C, 40 °C, 50 °C, 60 °C are better than temperatures of 20 °C, 22 °C, 30 °C, 52 °C, 60 °C. Can you see why?
- How many times shall I repeat each condition? Usually three times is the minimum requirement.
- How will I record my results? You should have a table prepared before you commence the investigation.

If, for some reason, you were unable to carry out the investigation, here are some results you could analyse.

*Substrate concentration*

Concentration of hydrogen peroxide/volume	Reaction rate/cm <sup>3</sup> s <sup>-1</sup>			
	Trial 1	Trial 2	Trial 3	Mean
0	0	0	0	
5	0.7	0.7	0.4	
10	1.6	1.9	1.6	
15	2.5	3.1	2.8	
20	2.9	3.0	3.7	

You can copy the table, calculate the mean and plot a graph of the mean reaction rate against the concentration of hydrogen peroxide.

*Temperature*

These results come from a class who varied the procedure slightly. They timed how long it took to produce 30 cm<sup>3</sup> oxygen at different temperatures. So before you can plot your graph of reaction rate, you must first:

- calculate the mean result for each temperature, and
- convert this to a volume per second (or per minute).

Temperature/°C	Time taken to collect 30 cm <sup>3</sup> oxygen in seconds			
	Trial 1	Trial 2	Trial 3	Mean
10	54	47	43	
20	12	14	16	
30	5	5	5	
35	9	5	4	
40	9	6	9	
45	14	11	11	
50	73	71	57	
55	119	109	132	

Once you have calculated the mean rates for each temperature, plot a graph of reaction rate against temperature.

### How do other substances affect enzyme activity?

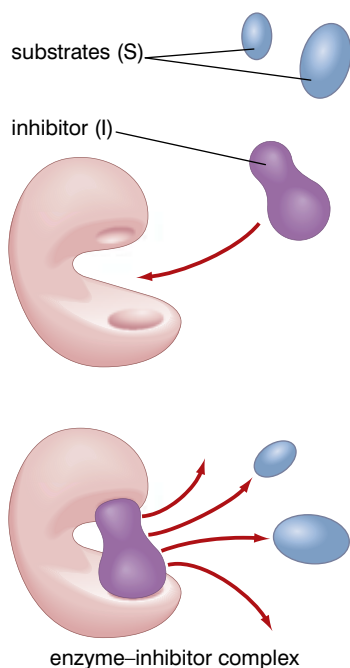
**Inhibitors** are substances that bind to enzymes and prevent them from forming enzyme–substrate complexes and, as a result, stop, or slow down, the reaction. There are two main types of inhibitors:

- irreversible inhibitors, and
- reversible inhibitors.

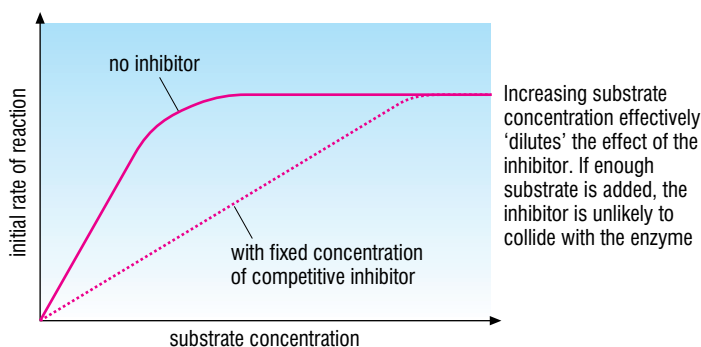
Irreversible inhibitors bind strongly to enzymes, usually by a covalent bond, permanently altering the structure of the enzyme

### Activity 3.8

Plan an investigation into the effect of pH on the rate of an enzyme controlled reaction such as the breakdown of starch by the enzyme amylase in saliva or the breakdown of hydrogen peroxide by the enzyme catalase in potato or liver. Explain how you would vary the pH of the reacting mixture and suggest what results you would expect to see.



**Figure 3.20** Competitive inhibition



**Figure 3.21** Effect of substrate concentration on inhibition by a competitive inhibitor

### KEY WORDS

**competitive inhibitor** a molecule that inhibits enzyme activity by competing with the substrate for the active site

**non-competitive inhibitor** a molecule that alters the conformation of the active site by binding with the allosteric site of the enzyme; it prevents the substrate from binding and inhibits enzyme activity

molecule and inactivating it. The painkiller aspirin is an example of an irreversible inhibitor. It binds with the enzyme cyclo-oxidase-2, which is an important enzyme in producing prostaglandins which give the sensation of pain.

Reversible inhibitors bind to enzymes only weakly and the bond that holds them breaks easily releasing the inhibitor. This allows the enzyme to become active again. There are two main kinds of reversible inhibitors:

- **competitive inhibitors**, and
- **non-competitive inhibitors**.

### Competitive inhibitors

Competitive inhibitors have molecules with shapes that are complementary to all, or part, of the active site of an enzyme. They are often similar in shape to the substrate molecules. They can bind with the active site and prevent substrate molecules from binding. The binding is only temporary and the competitive inhibitor is quickly released. A competitive inhibitor blocks the active site so substrate molecules cannot bind.

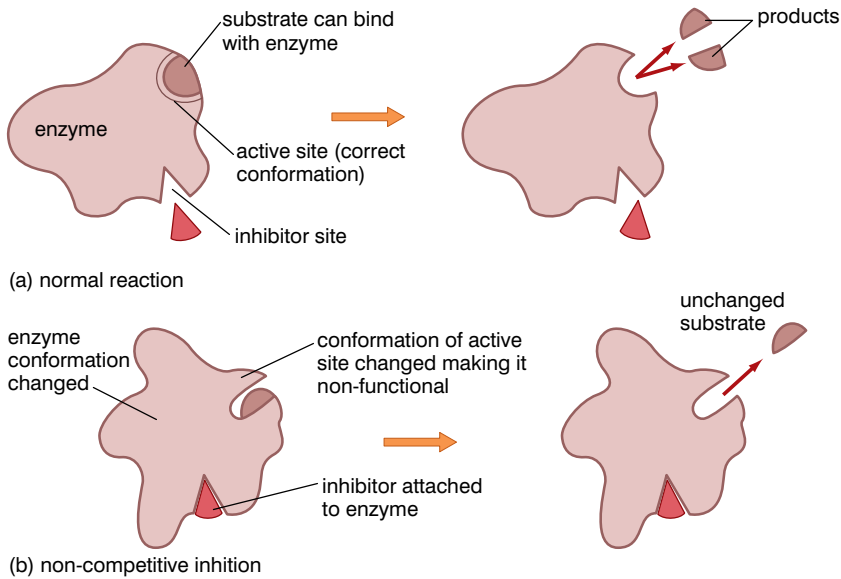
The overall effect on the rate of reaction depends on the relative concentrations of substrate and inhibitor molecules. Each molecule of competitive inhibitor can inhibit (temporarily) one enzyme molecule – but only if it can collide with the enzyme molecule and bind with the active site. To do this, it must compete with the substrate molecules for the active site – hence the name, competitive inhibitor. If there were 99 substrate molecules for every inhibitor molecule, then 99% of the collisions would be between enzyme and substrate and the reaction would proceed at 99% of the maximum rate. If the ratio were 90 substrate molecules to ten inhibitor molecules, there would be 10% inhibition and the reaction rate would fall to 90% of maximum.

The painkiller ibuprofen acts as a competitive inhibitor of the enzyme cyclo-oxidase-2, competing with the precursors of prostaglandins, which are the substrate of cyclo-oxidase-2. The metabolic poison cyanide acts as a competitive inhibitor of the enzyme cytochrome oxidase, an important enzyme in the release of energy in respiration.

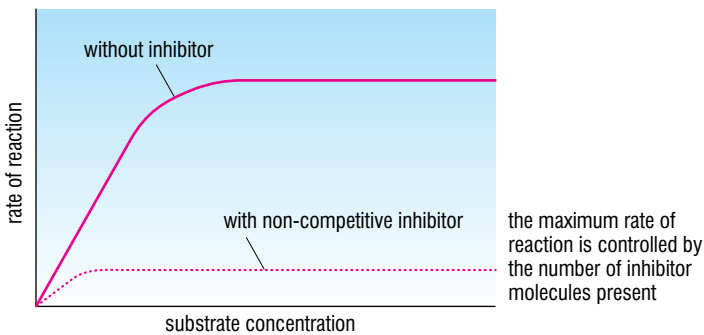
### Non-competitive inhibitors

Non-competitive inhibitors do not compete for the active site. Instead, they bind to another part of the enzyme called the allosteric site. This produces a conformational change in the part of the enzyme molecule that includes the active site. Because of this, the active site is a different shape and can no longer bind with the substrate to catalyse the reaction.





**Figure 3.22** Non-competitive inhibition



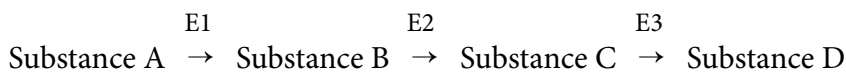
**Figure 3.23** The effect of substrate concentration on a non-competitive inhibitor

The effectiveness of a non-competitive inhibitor is in no way affected by the concentration of the substrate. Suppose there are enough inhibitor molecules to bind with the allosteric sites of 80% of the enzyme molecules. 80% of the enzyme molecules will be inhibited irrespective of the number of substrate molecules (as the two are not competing for the same site) and the reaction rate will drop to 20% of maximum.

Non-competitive inhibitors are particularly important in regulating metabolic pathways in cells.

### How do inhibitors control enzyme activity in living cells?

Many substances are produced in cells as a result of a metabolic pathway (a series of reactions), which can be represented as:



E1, E2 and E3 are enzymes catalysing the reactions.

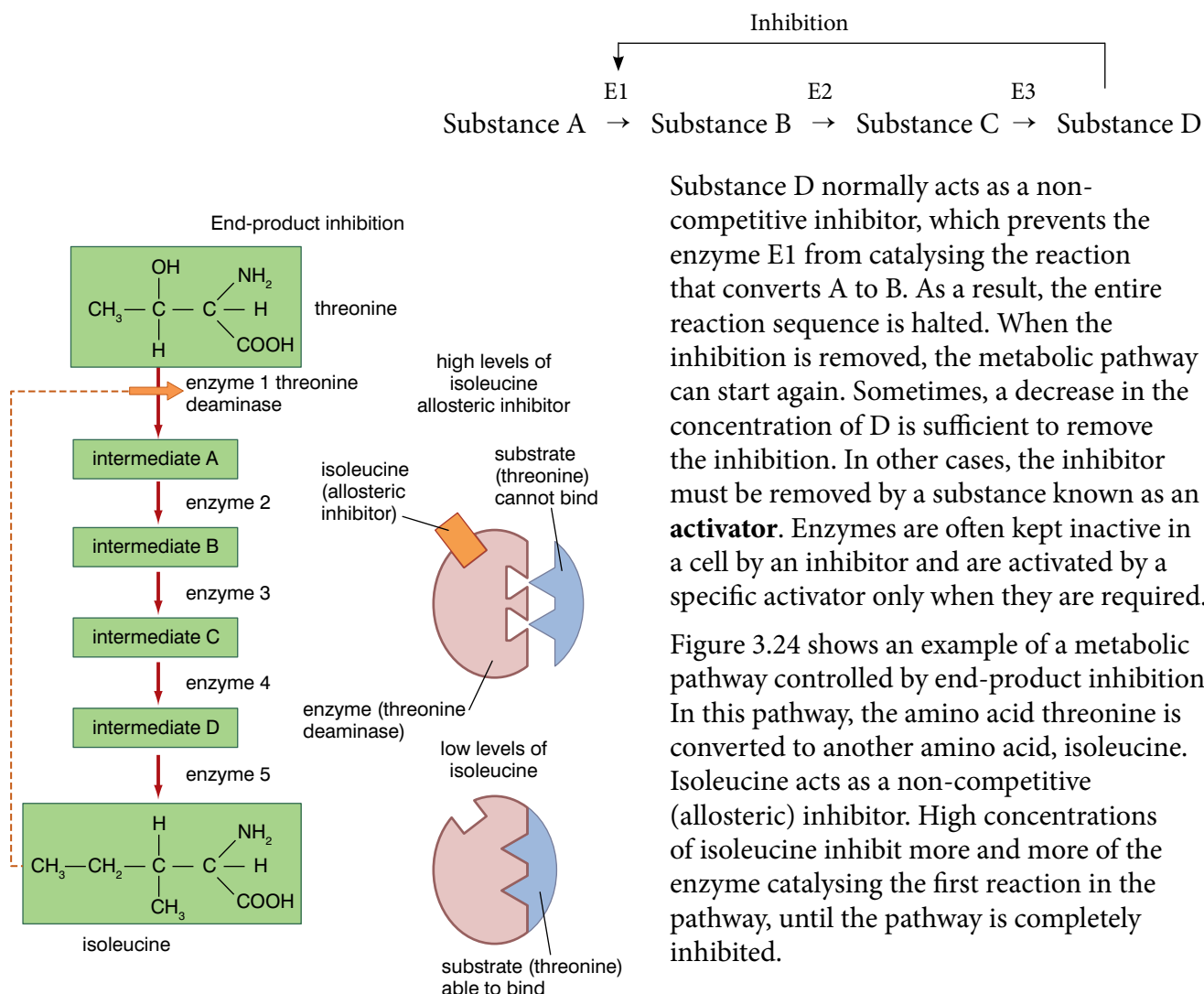
All the reactions in this sequence are enzyme controlled. Therefore, inhibition of any of these enzymes will interrupt the process. However, the main function of this pathway is to produce substance D for use by the cell. If the requirement for substance D in the cell decreases, then the concentration of D will increase. This is at

#### KEY WORDS

**end-product inhibition** when an end product inhibits the enzyme controlling the first stage of a reaction sequence

**activator** a substance that removes an inhibitor

least inefficient (producing something that is not being used) and may be potentially harmful because high concentrations could be toxic. Such reaction sequences are often controlled by **end-product inhibition**. The end product (D) inhibits the enzyme controlling the first stage of the reaction sequence, as shown in the diagram.



**Figure 3.24** A metabolic pathway controlled by end-product inhibition

Substance D normally acts as a non-competitive inhibitor, which prevents the enzyme E1 from catalysing the reaction that converts A to B. As a result, the entire reaction sequence is halted. When the inhibition is removed, the metabolic pathway can start again. Sometimes, a decrease in the concentration of D is sufficient to remove the inhibition. In other cases, the inhibitor must be removed by a substance known as an **activator**. Enzymes are often kept inactive in a cell by an inhibitor and are activated by a specific activator only when they are required.

Figure 3.24 shows an example of a metabolic pathway controlled by end-product inhibition. In this pathway, the amino acid threonine is converted to another amino acid, isoleucine. Isoleucine acts as a non-competitive (allosteric) inhibitor. High concentrations of isoleucine inhibit more and more of the enzyme catalysing the first reaction in the pathway, until the pathway is completely inhibited.

## Review questions

Choose the correct answer from A to D.

- When an enzyme is subjected to excess heat:
  - bonds in the active site are strained
  - some of the bonds in the active site break
  - the active site undergoes a conformational change
  - all of the above

2. Extreme pHs can inactivate enzymes because they:
  - A alter the charge on the amino acids in the allosteric site
  - B alter the charge on the amino acids in the active site
  - C alter the charge on amino acids away from the active site and allosteric site
  - D all of the above
3. The optimum temperature of an enzyme is the temperature at which:
  - A there is no denaturation
  - B the maximum number of enzyme–substrate complexes are formed
  - C there is the maximum number of collisions between enzyme and substrate
  - D the particles have the most kinetic energy
4. A non-competitive enzyme inhibitor...
  - A does not compete for the active site
  - B binds with the allosteric site
  - C binds with the active site of the enzyme
  - D is not affected by the substrate concentration
5. If the ratio of non-competitive inhibitor molecules to substrate molecules is 3:7, the enzyme controlling the reaction will be:
  - A 70% inhibited
  - B 30% activated
  - C 30% inhibited
  - D three-sevenths inhibited
6. When investigating the effect of temperature on enzyme activity, we should control:
  - A pH
  - B substrate concentration
  - C enzyme concentration
  - D all of these
7. End-product inhibition of a metabolic pathway occurs when:
  - A the last product of the pathway inhibits the enzyme controlling the first reaction
  - B the last product of the pathway inhibits the enzyme controlling the last reaction
  - C the first product of the pathway inhibits the enzyme controlling the last reaction
  - D the last product of the pathway inhibits the enzyme controlling the first reaction

**Activity 3.9**

Plan an investigation into the effect of changing the substrate concentration on the rate of an enzyme controlled reaction such as the breakdown of starch by the enzyme amylase in saliva or the breakdown of hydrogen peroxide by the enzyme catalase in potato or liver. Explain how you would vary the concentration of the substrate and suggest what results you would expect to see.

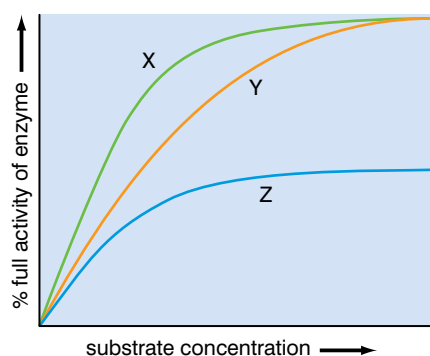


Figure 3.25

8. Figure 3.25 shows the activity of an enzyme at different substrate concentrations under three conditions:
- no inhibitor present
  - a competitive inhibitor present
  - a non-competitive inhibitor present

Which of the following represents the correct interpretation of the graph:

- A X is with the competitive inhibitor, Y with the non-competitive inhibitor and Z with no inhibitor
- B X is with the non-competitive inhibitor, Y with the competitive inhibitor and Z with no inhibitor
- C X is with no inhibitor, Y with the non-competitive inhibitor and Z with the competitive inhibitor
- D X is with no inhibitor, Y with the competitive inhibitor and Z with the non-competitive inhibitor
9. As temperature increases up to the optimum, the rate of an enzyme-controlled reaction increases because:
- A the particles have more kinetic energy
- B there are more collisions between enzyme and substrate
- C there are more enzyme–substrate complexes formed
- D all of these
10. If substrate concentration is kept permanently high and the enzyme concentration is gradually increased, the rate of activity of the enzyme will:
- A increase
- B increase and then decrease
- C increase and then level off
- D stay the same

## Summary

In this unit you have learnt that:

### Catalysts

- A catalyst speeds up a chemical reaction with no effect on:
  - the products formed
  - the energy change
  - the nature of the catalyst itself
- A catalyst speeds up a reaction by lowering the activation energy required for reactants to enter the transition state.
- Nearly all biological catalysts are enzymes. They are globular proteins with a specific tertiary shape, part of which forms an active site.

- A substrate molecule binds with the active site to form an enzyme–substrate complex. This then forms the products. The products are released from the enzyme molecule, which is unaltered.

#### Models of enzyme action

- The lock-and-key model of enzyme action suggests a rigid structure for the enzyme molecule, with the shape of the substrate and active site being complementary to each other. This model explains enzyme specificity but not how the transition state is achieved.
- The induced-fit model of enzyme action suggests that binding of the substrate induces a conformational change in enzyme structure, which puts the substrate molecule under tension, causing it to enter the transition state.
- The number of substrate molecules that bind to the active site of an enzyme molecule per second is the turnover rate.

#### Factors affecting enzyme activity

- Temperature – below the optimum temperature, the low level of kinetic energy limits the number of enzyme–substrate complexes formed; above the optimum temperature, denaturation of the enzyme prevents binding of the substrate.
- pH – above and below the optimum pH, changes occur in the tertiary structure of the enzyme molecule and in the charges on the amino acids making up the active site; both prevent binding of the substrate.
- Substrate concentration – if the concentration of enzyme remains constant, increasing the substrate concentration increases the number of enzyme–substrate complexes formed until, at any one time, all the active sites are occupied; the rate of reaction increases to its maximum.
- Enzyme concentration – if the substrate concentration is high and constant, increasing the enzyme concentration increases the rate of reaction.
- Inhibitors:
  - competitive inhibitors have molecules that are often similar in shape to the substrate molecules and that compete for the active site; the extent of the inhibition depends on the ratio of substrate molecules to inhibitor molecules
  - non-competitive (allosteric) inhibitors bind to a region away from the active site, producing a conformational change in the enzyme that prevents the substrate from binding; the extent of the inhibition is independent of the substrate concentration
  - allosteric inhibition can control metabolic pathways; the final product of a series of reactions inhibits the enzyme controlling the first reaction in the series; this is also known as end-product inhibition.

#### Activity 3.10

You know that a high temperature can denature an enzyme but it can be difficult to imagine how this happens. However you can demonstrate the effect very easily. Take an egg and separate the yolk from the white. Then divide the white between two test tubes. Egg white is pure protein and the coiled protein molecules are similar to the protein molecules which form enzymes.

Keep one tube at room temperature. Place the other in a beaker of boiling water and leave it for several minutes. Observe what happens and explain what you see in terms of changes to the coiled protein molecules in the raw egg white.

### End of unit questions

1. a) What is a cofactor?
- b) The table shows the various groups that can combine to form a holoenzyme. Copy and complete the table by placing a tick (✓) or a cross (✗) in each box.

Type of group	Organic	Protein	Binds tightly
Apoenzyme			
Coenzyme			
Ion			

2. When conducting investigations into the activity of enzymes, a number of factors need to be controlled. Copy and complete the table to describe the reasons for controlling these factors.

Factor controlled	How controlled	Reason for controlling factor
Temperature		
pH		Changes in pH can alter charge on amino acids in the active site.
Substrate concentration	Equal strength solutions	

3. Figure 3.26 shows the activity of two enzymes at different temperatures.

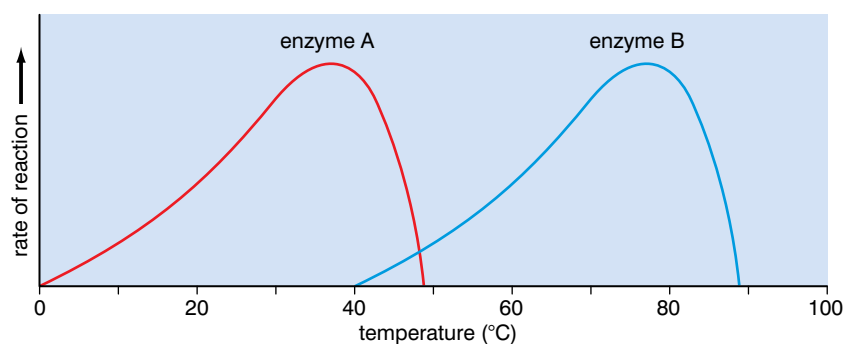


Figure 3.26

- a) What is the optimum temperature of each enzyme? Give reasons for your answers.
- b) Which enzyme may have come from a thermophilic bacterium? Give the reasons for your answer.
- c) Describe and explain the shape of the curve from 20 °C to 35 °C for enzyme A. Explain your answer.

4. Figure 3.27 shows the rate of reaction of an enzyme at 25 °C at different substrate concentrations.

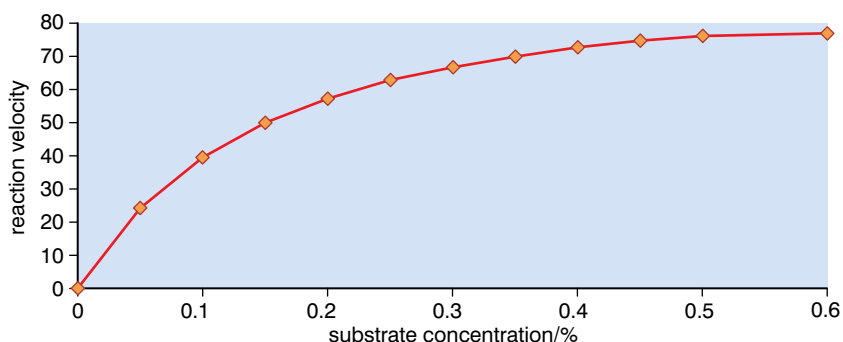


Figure 3.27

- a) Describe and explain the shape of the graph in terms of kinetic theory and enzyme–substrate complex formation:
- from substrate concentration 0.05% to 0.4%
  - from substrate concentration 0.4% to 0.6%
- b) Copy the graph and sketch, on your copy, the curve you would expect if the experiment had been carried out at 35 °C rather than 25 °C.

5. Figure 3.28 shows an energy level diagram of a reaction proceeding without an enzyme and the same reaction with an enzyme.

- Describe *two* ways in which the energetics of the reactions are similar.
  - Describe and explain the differences between the regions marked X and Y on the diagram.
  - Explain why enzymes speed up biological reactions.
6. Enzymes are increasingly being used in industrial processes.
- Give three examples of industrial processes that use enzymes.
  - Give two reasons why enzymes are being increasingly used in industrial processes.
  - Explain one way in which the increased use of enzymes may benefit the environment.

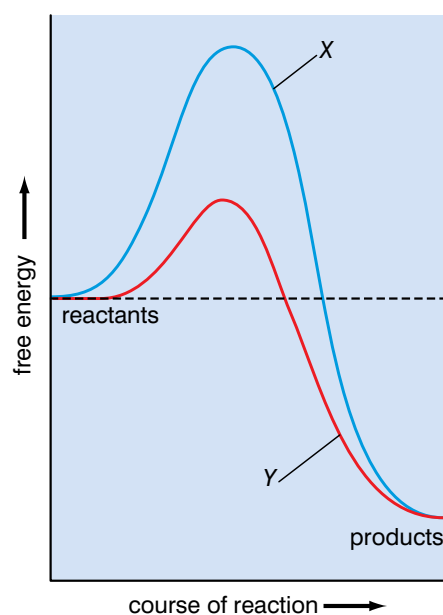


Figure 3.28

7. Students investigated the effect of temperature on the rate of activity of the enzyme catalase. They timed how long it took for potato tissue to produce 50 cm<sup>3</sup> oxygen at different temperatures. Figure 3.29 shows the graph that one student drew after averaging all the students' results.

- (i) According to this graph, what is the optimum temperature of catalase?
- (ii) Explain why this might not be an accurate estimate of the optimum temperature.

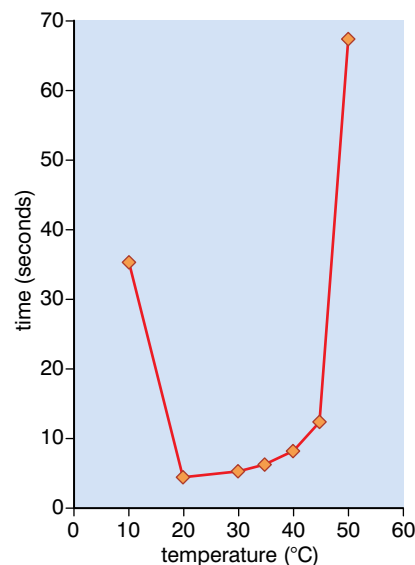
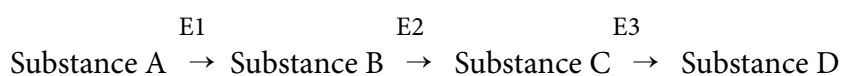


Figure 3.29

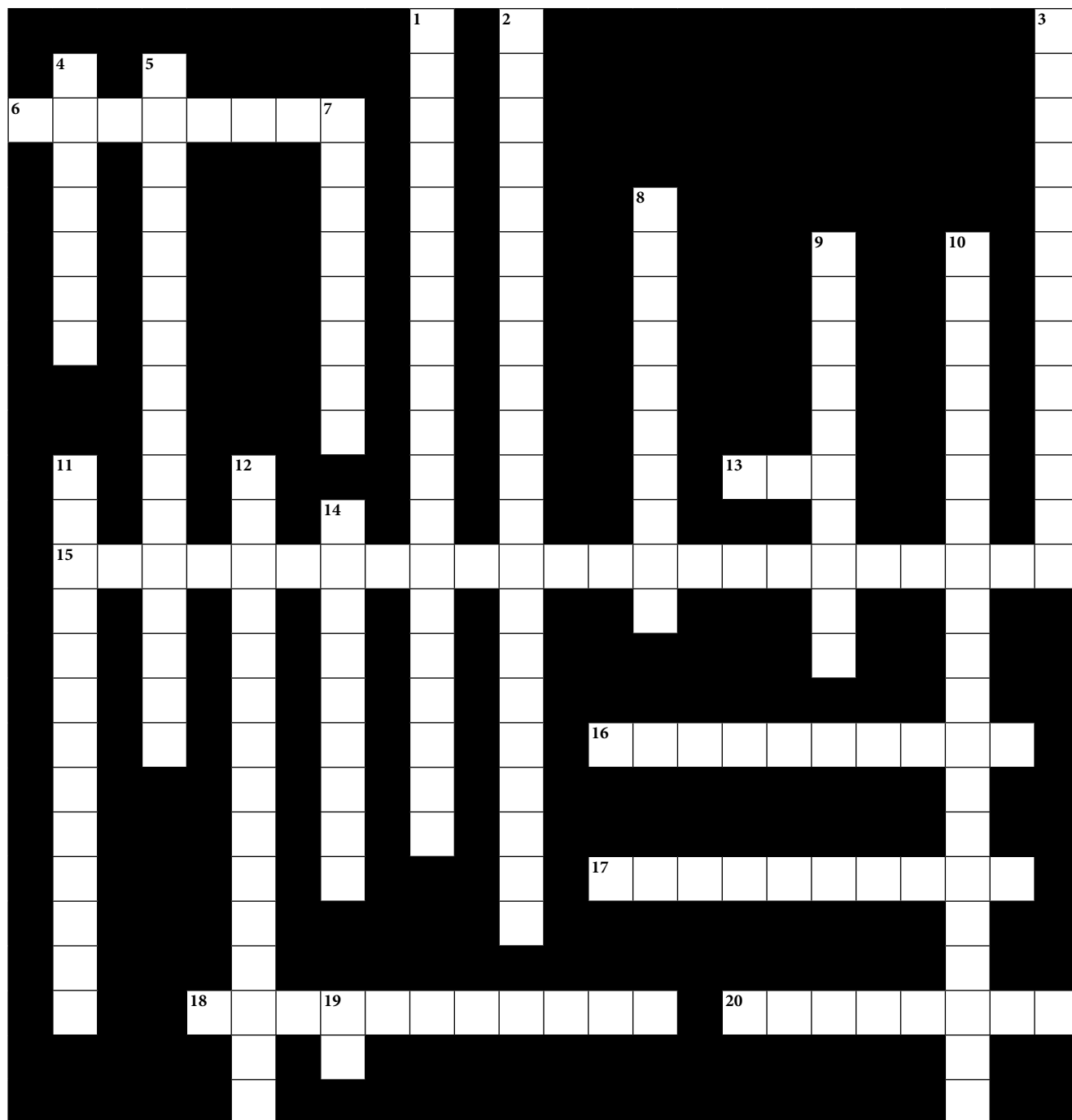
- b) In a control experiment (no enzyme present but all other factors the same as in the other experiments) carried out at 20 °C, 0.5 cm<sup>3</sup> of oxygen was collected. Assuming no experimental error, explain why this small amount of oxygen was produced.
- c) (i) Explain the difference in the volumes of oxygen collected at 10 °C and at 20 °C.
- (ii) Explain the difference in the volumes of oxygen collected at 35 °C and at 50 °C.
8. a) Explain what is meant by non-competitive (allosteric) inhibition.
- b) A metabolic pathway consists of a series of reactions controlled by enzymes, as shown below.



- (i) Use this example to explain what is meant by end-product inhibition.
- (ii) Explain how end-product inhibition can control enzyme activity in living cells.



Copy the crossword puzzle below into your exercise book (or your teacher may give you a photocopy) and solve the numbered clues to complete it.



### Across

6. Means that enzymes only catalyse one reaction (8)
13. The names of most enzymes ends in these three letters (3)
15. This slows a reaction by binding to the allosteric site of an enzyme (3-11, 9)
16. A model of enzyme action in which the active site changes shape as the substrate binds (7, 3)
17. Literally means 'water-splitting' (10)

18. If this is too high, enzymes are denatured (11)
20. A substance (sometimes a vitamin) necessary for the functioning of an enzyme (8)

**Down**

1. Enzymes are sometimes described as these (10, 9)
2. This is formed when an enzyme and its substrate bind (6-8, 7)
3. This cleaning substance for clothes often contains enzymes (7, 6)
4. The temperature at which an enzyme is most active is called this (7)
5. The energy needed before a reaction will proceed (10, 6)
7. A substance that speeds up a chemical reaction, but remains unchanged itself (8)
8. A model of enzyme action in which enzyme and substrate fit together like an egg and egg cup (4, 3, 3)
9. The part of an enzyme that binds with its substrate (6, 4)
10. This slows a reaction by competing with the substrate for the active site of an enzyme (11, 9)
11. The amount of substrate per 100 cm<sup>3</sup> is its ... (13)
12. All enzymes are this type of molecule (8, 7)
14. The main part of an enzyme that consists of two molecules (9)
19. This can influence how active enzymes are (2)

Contents	
Section	Learning competencies
4.1 Cell theory (page 112)	<ul style="list-style-type: none"> <li>• Tell the history of cell biology.</li> <li>• Describe cell theory and investigate the size, structure and shape of cells.</li> <li>• State the basic functions of cells.</li> <li>• Appreciate that all life on Earth originates from cells.</li> </ul>
4.2 Types of cells (page 121)	<ul style="list-style-type: none"> <li>• Appreciate that there are just two basic types of cells: prokaryotic and eukaryotic cells.</li> <li>• Give examples and describe the basic structure of each type.</li> <li>• Explain the difference between prokaryotic and eukaryotic cells.</li> </ul>
4.3 Parts of the cell and their functions (page 125)	<ul style="list-style-type: none"> <li>• Discuss the importance of a cell membrane.</li> <li>• Describe the composition and arrangement of lipids and proteins in the membrane.</li> <li>• Compare the Davson–Danielli and fluid mosaic models.</li> <li>• Construct and show the arrangement of the phospholipids and proteins in the fluid mosaic model.</li> <li>• Explain the role of glycoprotein and other components in the cell membrane.</li> <li>• Name the different parts of the cell and explain their functions.</li> <li>• State and explain the mechanisms of substance transport across a cell membrane.</li> <li>• Conduct an experiment to show movement of solvent through a semi-permeable membrane.</li> <li>• Demonstrate osmosis at a semi-permeable membrane.</li> <li>• Explain that the size of a cell changes by osmosis because of the inflow and outflow of water.</li> <li>• Appreciate that osmosis is responsible for everyday life phenomena.</li> </ul>

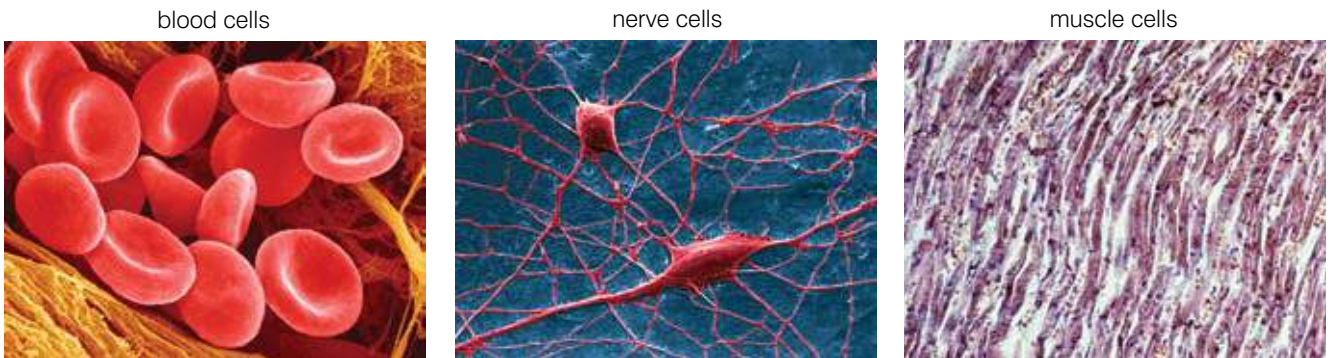
## 4.1 Cell theory

By the end of this section you should be able to:

- Tell the history of cell biology.
- Describe cell theory and investigate the size, structure and shape of cells.
- State the basic functions of cells.
- Appreciate that all life on Earth originates from cells.

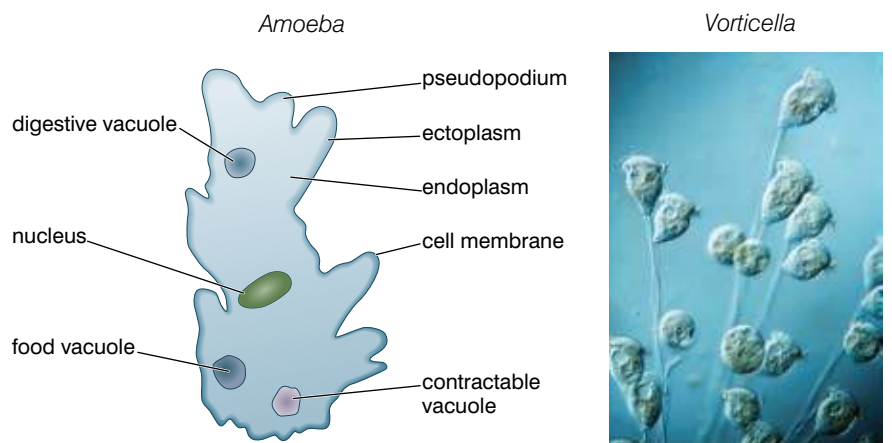
### How did the modern cell theory develop?

Today we take it for granted that living things are made of cells. Billions of cells in the case of human beings, just one cell in the case of organisms like amoeba. Figure 4.1 shows some of the different types of cells that make up our bodies.



**Figure 4.1** Some of the different cells in our bodies

There is only one cell in *Amoeba* and in *Vorticella*.



**Figure 4.2** The unicellular organisms *Amoeba* and *Vorticella*

It seems strange that the idea of organisms being made from cells is a relatively recent idea. Only a few hundred years ago, cells had not been discovered. Their discovery had to wait for the development of reliable microscopes that could magnify sufficiently to show the cellular structure of living organisms. Many biologists and other scientists contributed to the discovery of cells and the statement of the very first cell theory. The timeline below shows some of the major contributors.

## A timeline for the development of the cell theory

**1665** Robert Hooke, with one of the earliest compound microscopes, makes drawings of cork and sees tiny structures that he calls 'cells'. However, although his microscope is a compound microscope, the lenses are not very good and magnifications of more than 30× are very blurred and do not show much detail. Also, Hooke saw only dead cells.



**Figure 4.3** Robert Hooke's drawing of cells in cork

**Figure 4.4** Robert Hooke's microscope

**1674** Anton van Leeuwenhoek sees living, moving unicellular organisms (protocists) in a drop of water. He is using a simple microscope with only one lens. It is really little more than a magnifying glass with a mount for the specimens.

However, van Leeuwenhoek is very skilled at grinding lenses and so his microscope can achieve magnifications of 300×. He calls the moving organisms 'animalcules'. He also sees bacteria (from his teeth), which he also calls 'tiny animalcules'.



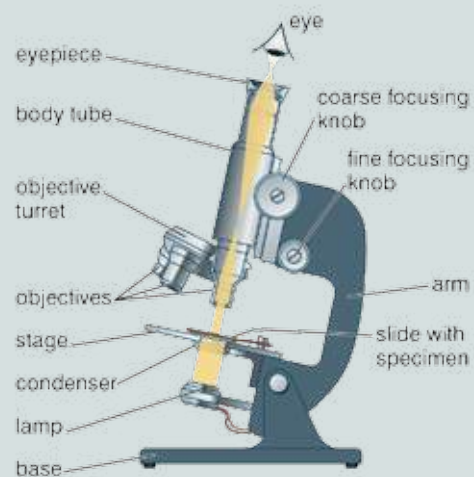
**Figure 4.5** Anton van Leeuwenhoek's microscope



**Figure 4.6** Anton van Leeuwenhoek

### About compound microscopes

A compound microscope is the sort of microscope we use in biology today. It has two lenses – the eyepiece and the objective lens (check back to unit 1 for more details) – that combine to produce the final image. Because two lenses are used, compound microscopes are capable of higher magnifications than simple microscopes, which use only one lens. The second lens (the eyepiece) magnifies the already magnified image produced by the objective lens. However, it also magnifies any 'aberrations' or faults in the image. So if the lenses are not well made, the final image, at high magnifications, will be blurred. The first compound microscope was made in 1595 by the Dutch scientist, Zaccharias Jansen.



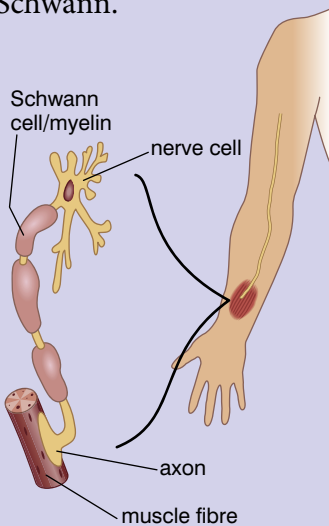
**Figure 4.7** A modern compound microscope

Check back to unit 1 to look at the work of Francesco Redi and Louis Pasteur in disproving spontaneous generation.

**DID YOU KNOW?**

**About Schwann cells**

Schwann cells are special cells that contain a lot of a fatty substance called myelin. They wrap themselves around the axons of nerve cells as the nerve cells are growing and insulate the axons. They are named in honour of Theodor Schwann.



**Figure 4.8** Schwann cells around the axon of a nerve cell

**1824** The French biologist Rene Dutrochet concludes that all organisms are composed of cells. This follows many years work in which he also discovers:

- the stomata in the epidermis of leaves
- the process of osmosis
- chlorophyll is needed for photosynthesis to occur
- respiration occurs in both animals and plants

In many ways, Dutrochet is the man who first states the cell theory by recognising that all organisms are made of cells and that ‘all growth occurs because of the increase in volume of cells or by the addition of more little cells’.

**1839** Matthias Schleiden and Theodor Schwann put forward the first clearly stated cell theory. It states that:

- the cell is the unit of structure, physiology and organisation in living things
- the cell retains a dual existence as:
  - a distinct entity, and
  - a ‘building block’ in the formation of organisms
- cells form by free-cell formation (spontaneous generation)

Although we still accept the first two ideas, the final idea of spontaneous generation has now been proved false.

**1858** Rudolf Virchow, a German doctor who develops many surgical techniques and promotes several fields of modern medicine, declares that: ‘*Omnis cellula e cellula*’, which means that a cell can only arise from another cell like it. With this he completes the first accepted version of the cell theory:

- all organisms are made up of one or more cells
- all cells come from pre-existing cells
- the cell is the unit of structure, physiology and organisation in living things
- the cell retains a dual existence as a distinct entity and a building block in the construction of organisms

Today, this has been modified and extended in the light of our increased knowledge of genetics and cell biology and now reads:

- all known living things are made up of cells
- the cell is a structural and functional unit of all living things

- all cells come from pre-existing cells by division (there is no spontaneous generation of cells)
- cells contain hereditary information which is passed from cell to cell during cell division
- all cells have basically the same chemical composition
- all energy flow (the metabolism and biochemistry of life) occurs within cells

Besides these major steps in the development of a cell theory, there have been other developments in the study of cell biology. Some of these are listed below.

### Key events in the study of cell biology

**Table 4.1** Key events in cell biology

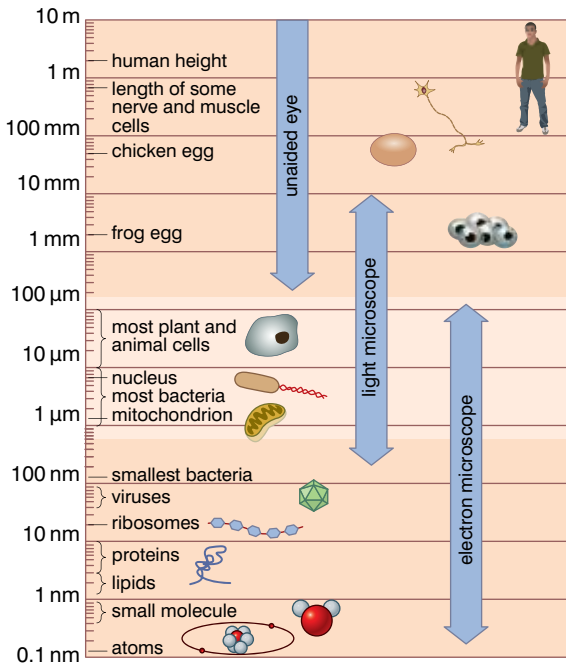
	Event
1595	Jansen builds the first compound microscope.
1626	Redi postulates that living things do not arise from spontaneous generation.
1665	Hooke describes 'cells' in cork.
1674	Leeuwenhoek discovers protozoa.
1833	Brown describes the cell nucleus in cells of an orchid.
1839	Schleiden and Schwann propose a cell theory.
1857	Kolliker describes mitochondria.
1858	Virchow states <i>omnis cellula e cellula</i> .
1869	Miescher isolates DNA.
1879	Fleming describes chromosome behaviour during mitosis.
1898	Golgi describes the Golgi apparatus in cells.
1939	The first transmission electron microscope.
1953	Watson and Crick propose the double-helix structure of DNA.
1965	The first scanning electron microscope.
2000	Human genome DNA sequence draft.

### How big are cells?

It all depends on what kind of cell you are talking about. The contents of a chicken's egg are just one huge cell packed with food – it's a pretty big cell, up to 5 cm (0.05 m) in length. On the other hand, the smallest bacterial cells are only just over 100 nm in length. This is approximately one hundred-thousandth of the size of the chicken's egg. That's quite a range of sizes!

### Activity 4.1

Work in groups for this activity. Each group is going to make a presentation to the class about one of the following scientists who all made a major contribution to our modern understanding of cells: Robert Hooke, Anton van Leeuwenhoek, Rene Dutrochet, Matthias Schleiden, Theodor Schwann and Rudolf Virchow. Use this textbook as a resource and use other books and the internet for your research if it is available. Make your presentations as interesting and lively as possible.



**Figure 4.9** Size and scale in living things

**What units shall we measure cells in?**

Again, it all depends on which cells, but first we should understand which units are available and which ones would be convenient to use. We could measure cells in metres, but the size of a red blood cell in metres would be approximately 0.000007 m.

All those 0's are very confusing and we don't easily work with such small numbers. So we use other, smaller units to measure the size of cells and molecules. These smaller units give us numbers that are more convenient to work with. There are three smaller units commonly used:

- millimetres (mm) – 1/1000 of a metre
- micrometres (µm) – 1/1000 of a millimetre, and 1/1 000 000 of a metre
- nanometres (nm) – 1/1000 of a micrometre, 1/1 000 000 of a millimetre, and 1/1000 000 000 of a metre

We can convert the units from one to another as shown below:

$$\begin{array}{ccccccc}
 & \times 1000 & & \times 1000 & & \times 1000 & \\
 \text{m} & \longleftarrow & & \longleftarrow & & \longleftarrow & \\
 & \div 1000 & & \div 1000 & & \div 1000 & \\
 & & \text{mm} & & \mu\text{m} & & \text{nm}
 \end{array}$$

To convert a larger unit to the next smaller unit, multiply by 1000:

For example, convert 3.5 mm to µm.  
 $3.5 \text{ mm} = 3.5 \times 1000 = 3500 \mu\text{m}$

To convert a smaller unit to the next larger unit, divide by 1000:

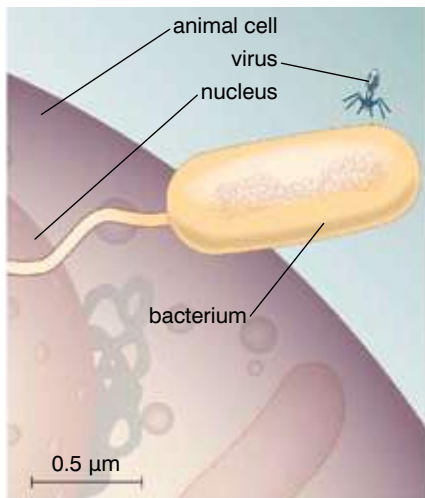
For example, convert 87 nm to µm.  
 $87 \div 1000 = 0.087 \mu\text{m}$

So, our red blood cell that was 0.000007 m in diameter is 0.007 mm or 7 µm in diameter. This is a much more comprehensible number.

Most cells fall within a much narrower range of sizes than the chicken's egg and the smallest bacterium. As you can see from figure 4.9, the length of most animal and plant cells fall within a range of 10 µm to 100 µm. Most bacteria are about one-tenth of this length.

Figure 4.10 shows the relative sizes of an animal cell, a bacterium and a virus in a slightly different way. This diagram makes it clear just how much bigger an animal cell is than a bacterium.

The animal cell may be just ten times as long – but it is also ten times as wide and ten times as deep. This makes it 1000 times bigger than the bacterium!



**Figure 4.10** The relative size of an animal cell, a bacterial cell and a virus

**KEY WORDS**

**calibrating** correlate the readings of an instrument with a standard



### Activity 4.2: How can we find out how big cells are?

To do this properly, you need to use two measuring devices with your microscope:

- a stage micrometer – this is really a microscope slide with a very precise scale etched onto it, and
- an eyepiece graticule – this is a piece of plastic with a less accurate scale than the graticule that fits inside the eyepiece of the microscope.

When you put the micrometer onto the slide and look at it through the eyepiece containing the graticule, you see something like figure 4.11.

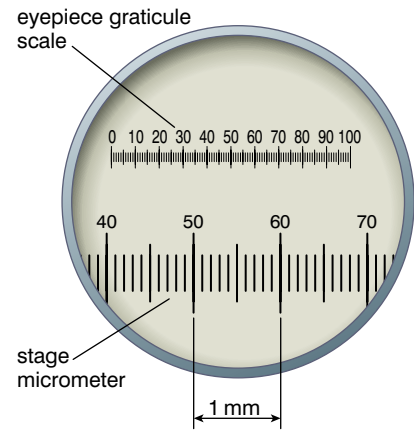
The smallest divisions on the stage micrometer slide are  $100\ \mu\text{m}$ . So each large division on the stage micrometer is 10 times that – 1 mm.

If we look at the two scales, we can see that the range 50–60 on the stage micrometer corresponds with the range 35–72 on the graticule. Ten divisions on the micrometer scale correspond to 37 divisions on the graticule scale and 1 micrometer division therefore corresponds to 3.7 graticule divisions. But we know that 1 micrometer division =  $100\ \mu\text{m}$  (or 0.1 mm).

So 1 division of the eyepiece graticule =  $100\ \mu\text{m} \div 3.7 = 27\ \mu\text{m}$  (or 0.027 mm).

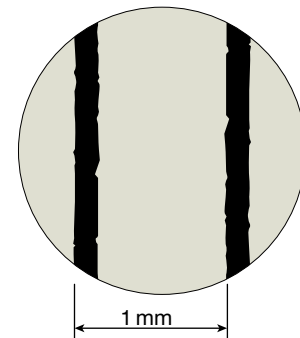
This is called **calibrating** the eyepiece graticule. If we now put an object on an ordinary slide (having removed the stage micrometer) and view it at the same magnification, we can calculate its size. If it takes up 26 graticule divisions, then this length is:  $26 \times 27 = 702\ \mu\text{m}$  (or 0.702 mm).

However, the graticule will need recalibrating if it is to be used at a different magnification.



therefore each small division =  $100\ \mu\text{m}$

**Figure 4.11** An eyepiece graticule and stage micrometer



**Figure 4.12** Estimating the field of view

#### How you can make a rough estimate of cell size

It's a way of using the same principle as the micrometer. It isn't as accurate, but it's a lot cheaper and easier.

- Place your slide of cells (for example, onion epidermis cells) under the microscope and get the cells in focus at about magnification  $\times 100$ .
- Now take the slide away and replace it with a transparent plastic ruler. (Keep the magnification the same.)
- Focus on the millimetre scale on the ruler. You will see something like figure 4.12.
- Use this to estimate the width of 'field of view'. You would probably estimate the field of view as shown in figure 4.12 at about 2 mm.
- Now replace your slide of the onion cells and refocus.
- Count how many cells fit lengthways and widthways into the field of view.
- If 8 cells fit across the field of view the width of each cell is  $2\ \text{mm} \div 8 = 0.25\ \text{mm}$  (or  $250\ \mu\text{m}$ ). However, this is only one estimate and you should repeat the procedure in several areas of the slide and find the average.

**KEY WORD**

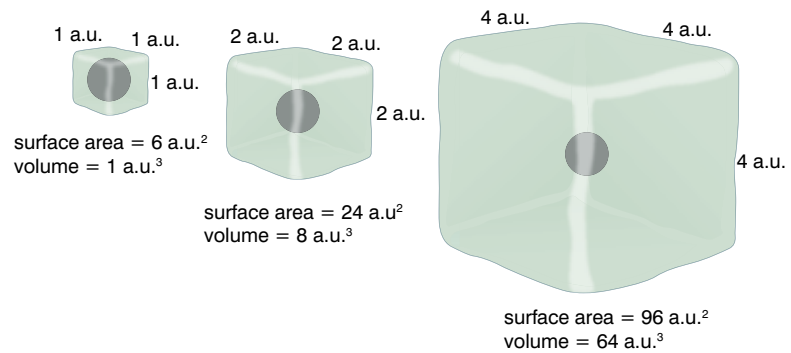
**arbitrary units** are units we use when we don't know actual dimensions but we know the mathematical relationship between different conditions

## What are the consequences of the different sizes of cells?

When a cell gets bigger, all its dimensions change. It is easy to be tricked into thinking that when a cell doubles all its dimensions it is twice as big. But, in fact, there is now eight times more cell as a result! This is most easily explained if we pretend that our cell is a cube, but the same principles hold true for other shapes also.

Look at figure 4.13. It shows three cubic 'cells' of different sizes. The linear dimensions double from the first cell to the second and double again from the second cell to the third. But the surface area and volume of the cell doesn't double.

There are six sides to a cube. We calculate the area of each side by multiplying length by breadth. In the case of the first cell, this is 1 **arbitrary unit** (a.u.)  $\times$  1 a.u., so the area of one side is 1 a.u.<sup>2</sup>. The volume of a cube is length  $\times$  breadth  $\times$  height. In this case 1 a.u.  $\times$  1 a.u.  $\times$  1 a.u. So the volume of the first cell is 1 a.u.<sup>3</sup>. The ratio of the surface area to the volume is 6:1.



**Figure 4.13** How increasing size affects surface area and volume. The measurements are in arbitrary units (a.u.).

So what about the second cell? The linear dimensions have doubled, but the surface area is 24 a.u.<sup>2</sup> and the volume is 8 a.u.<sup>3</sup>. The ratio of the surface area to volume is now  $24 \div 8 = 3:1$ . It is half that of the smaller 'cell'.

The ratio of the surface area to volume of the third cell is in fact 1.5:1. Smaller again and half the value of the ratio of the cell with linear dimensions that are half of this one.

### Activity 4.3: Can you spot a trend?

Calculate the surface area, volume and surface-area-to-volume ratio for cubes with linear dimensions ranging from 1 to 10. You could use a table like the one below.

Now plot a graph of your results. Plot linear dimensions on the x (horizontal) axis and surface-area-to-volume ratio on the y (vertical) axis. Describe the trend carefully.

Linear dimensions	Area of one side (l × b)	Total surface area (6 × l × b)	Volume (l × b × h)	Surface-area-to-volume ratio
1				6
2				3
3				
etc.				
10				

### So, does it matter if the surface-area-to-volume ratio changes?

To answer this question, we must think about the functions of the surface area of the cell and of the volume of the cell. It is best understood if we think of just one function – that of respiration. A cell respire to release energy to drive all the other cellular processes that take place. If it can't release enough energy, these other processes will slow down and the cell may die. In order to respire, the cell needs oxygen, which enters through the surface of the cell.

- The volume determines how much activity there is in a cell. A large cell will have more processes happening, or at least the same processes happening faster, than a smaller cell. The amount of energy that must be released in respiration is therefore decided largely by the volume.
- The amount of oxygen that can be delivered into the cell is decided largely by how much 'surface' there is, since it is through the surface of the cell that the oxygen enters.

A large surface-area-to-volume ratio means that it is likely that the surface will be able to supply the oxygen demands of the cell. But as cells increase in size, *the volume increases faster than the surface area* and the surface-area-to-volume ratio decreases. How will this affect the ability of the cell to release the energy it needs?

#### KEY IDEA

*Think of this surface-area-to-volume ratio in terms of 'supply' and 'demand'. The volume of the cell creates the 'demand' for oxygen, which is 'supplied' through the surface (area) of the cell.*

### Review questions

Choose the correct answer from A to D.

1. A compound microscope differs from a simple microscope in that it always has:
  - A more than one objective lens
  - B more than one ocular lens
  - C both ocular and objective lenses
  - D a condenser
2. The word 'cell' was first coined by Robert Hooke when he examined:
  - A living cells in cork tissue
  - B dead cells in cork tissue

**Activity 4.4: Debate**

Most biologists believe that a high surface area to volume ratio is advantageous to a cell.

Your teacher will divide the class into three groups:

- Group 1 – this group will present arguments to support the idea that a high surface area to volume ratio is advantageous to a cell
- Group 2 – this group will present arguments to support the idea that a low surface area to volume ratio is advantageous to a cell
- Group 3 – this group will form the ‘audience’ who will:
  - question the members of each of the other groups after their presentation
  - vote to decide the outcome of the debate

The debate will follow the following procedure:

- Group 1 will present their case (2 minutes)
- Group 2 will present their case (2 minutes)
- Groups 1 and 2 can question the other group and try to disprove their ideas (2 minutes)
- Group 3 (the audience) can question any members of any group (4 minutes)
- Group 3 votes on the issue

- C dead cells in skin
  - D living cells in skin
3. Anton van Leeuwenhoek saw what he called ‘animalcules’ and ‘tiny animalcules.’ These were, respectively:
    - A bacteria and viruses
    - B bacteria and protocistsans
    - C protocistsans and viruses
    - D protocistsans and bacteria
  4. In 1824, Rene Dutrochet stated that:
    - A all living cells come from other cells
    - B all living things are made of cells
    - C cells can be spontaneously generated
    - D cells cannot be spontaneously generated
  5. The first cell theory stated by Schleiden and Schwann was not completely accurate because it held that:
    - A all living things are made of cells
    - B the cell is the basic unit of living things
    - C the cell retains a dual existence
    - D cells form by cell-free formation
  6. The first correct cell theory was proposed by:
    - A Koliker
    - B Virchow
    - C Fleming
    - D Golgi
  7. To convert mm to  $\mu\text{m}$  we:
    - A multiply by 100
    - B divide by 100
    - C divide by 1000
    - D multiply by 1000
  8. 40 divisions on the scale of an eyepiece graticule correspond to 16 small divisions on the stage micrometer. Each small division on the stage micrometer =  $10\ \mu\text{m}$ . 4 cells fit across 40 divisions of the eyepiece graticule. The length of each cell is:
    - A  $10\ \mu\text{m}$
    - B  $40\ \mu\text{m}$
    - C 40 mm
    - D 10 mm

9. Cube A has a side measuring 3 mm. Cube B has a side measuring 12 mm. The surface-area-to-volume ratio of cube A when compared to cube B is:
- two times bigger
  - two times smaller
  - four times smaller
  - four times bigger
10. The surface-area-to-volume ratio of a cell is important because it is a measure of:
- how efficiently the cell releases energy in respiration
  - how efficient the cell is in conserving energy
  - how efficient the cell is in obtaining the oxygen it needs for respiration
  - how efficiently the cell uses the energy it releases in respiration

**KEY WORD**

**division of labour** *the specialisation of different parts to carry out certain functions*

## 4.2 Types of cells

By the end of this section you should be able to:

- Appreciate that there are just two basic types of cells: prokaryotic and eukaryotic cells.
- Give examples and describe the basic structure of each type.
- Explain the difference between prokaryotic and eukaryotic cells.

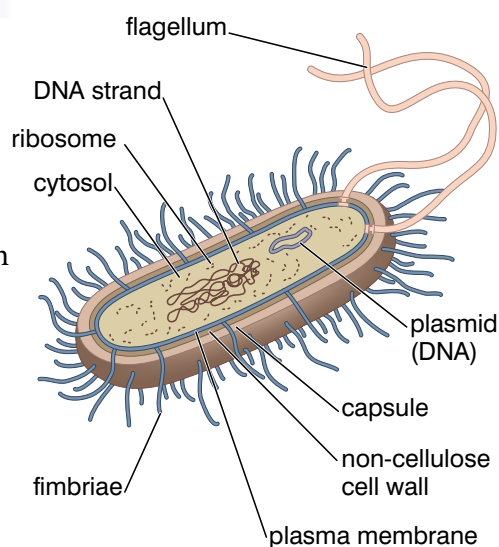
**DID YOU KNOW?**

The structure of the cell wall and capsule vary between different bacteria. You will learn more about this in grade 12.

### What are prokaryotic and eukaryotic cells?

Many biologists believe that **prokaryotic cells** were the first type of cells to be formed when life first evolved. Prokaryotic cells are much smaller and simpler than **eukaryotic cells**; even so these cells must carry out all the same functions that a eukaryotic cell carries out in order to survive. There is therefore some **division of labour** within the cell. There are specialised regions for certain functions. You can see this in figure 4.14.

However, there is much more division of labour in a eukaryotic cell. There are different types of eukaryotic cell, but all of them have a number of features in common. Figure 4.15 shows a generalised animal cell. Most of the structures shown are found in all eukaryotic cells. Plant cells have a number of other structures in addition to these, as figure 4.16 shows.



**Figure 4.14** A generalised prokaryotic cell

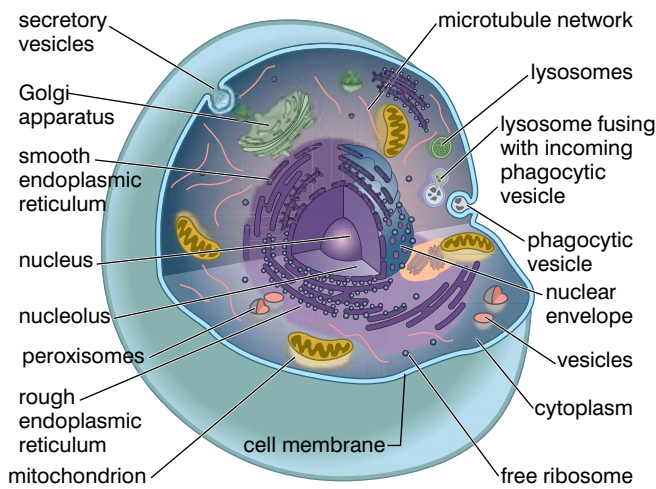


Figure 4.15 A generalised animal cell

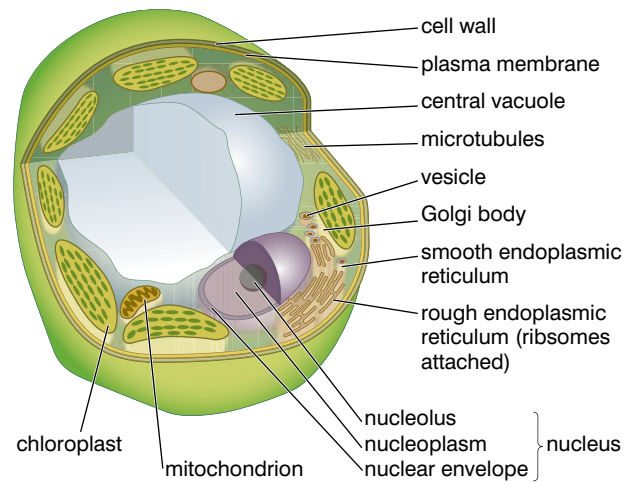


Figure 4.16 A generalised plant cell

**KEY WORDS**

**prokaryotic cell** a type of cell that does not have a nucleus. The word prokaryotic is derived from Greek pro (before) and karyos (nuclear)

**eukaryotic cell** a type of cell that has a nucleus. The word eukaryotic is derived from Greek eu (true) and karyos (nuclear)

**organelles** individual structures in a cell with a specific function

**endoplasmic reticulum** the network of membranes in a cell

**membrane-bound organelles** organelles surrounded by membranes

These are clearly much more complex cells than the prokaryotic cell. What is really different about them is that there are many more different individual structures, called **organelles**, in the cell. Also, there are many more membranes in the cell. Some of these form the complex membrane system that is found throughout the cell – the **endoplasmic reticulum**. In addition to these, several of the organelles are surrounded by membranes. These are the:

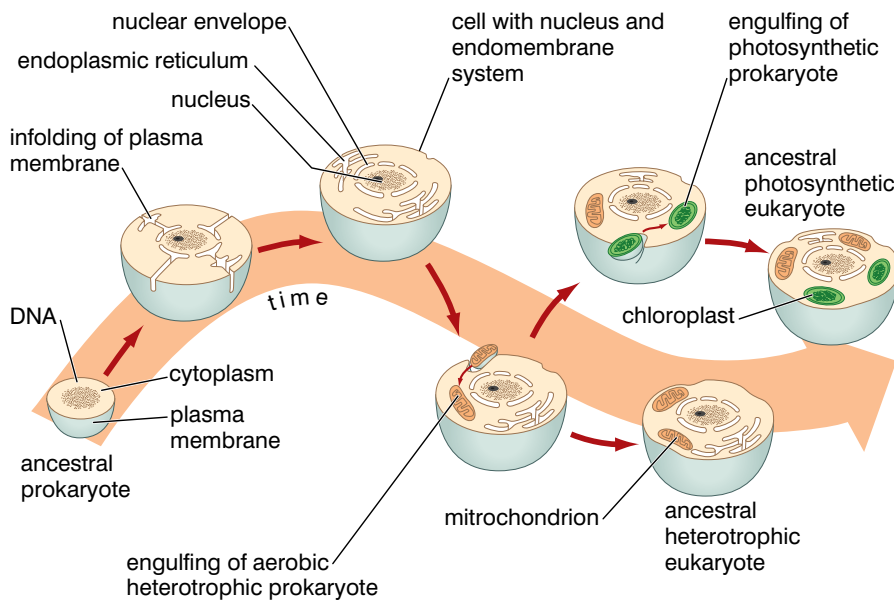
- nucleus
- mitochondria
- chloroplasts (if present)
- lysosomes
- Golgi apparatus

These are called **membrane-bound organelles**.

These membranes make the cell able to function more efficiently. Because each mitochondrion is enclosed by a membrane (actually by two membranes!), the reactions that take place here are not affected by other cellular reactions. The same applies to the other membrane-bound organelles. Also, membranes of the endoplasmic reticulum separate areas of the cytoplasm and allow them to function independently.

**How did eukaryotic cells originate?**

One theory is that the ‘modern’ eukaryotic cell was formed when several of the more primitive prokaryotic cells ‘got together’. Over millions of years ancestral prokaryotic cells became more membranous. The plasma membrane around the cell became more and more ‘infolded’ until there was an extensive membrane system in the cell. This would eventually evolve into the endoplasmic reticulum (EPR) of eukaryotic cells. The next stage in the theory suggests that this membranous cell engulfed other smaller cells that were better at respiring organic molecules to release energy.



**Figure 4.17** The origin of eukaryotic cells

These ‘engulfed’ prokaryotes would evolve into the mitochondria of eukaryotic cells. The cells that contained them were **heterotrophic** and the forerunners of animal, fungal and protoctistan cells. One further stage suggests that some of these cells with their ‘primitive mitochondria’ also engulfed other, smaller, prokaryotic cells. These were prokaryotic cells that could photosynthesise and would, in time, evolve into chloroplasts. The cells that contained these would be **autotrophic** and the forerunners of plant cells. This theory of the origin of eukaryotic cells is called the **endosymbiont theory** and was first proposed by the biologist Lynn Margulis.

**KEY WORDS**

**heterotrophic** these cells must absorb organic molecules ‘ready-made’

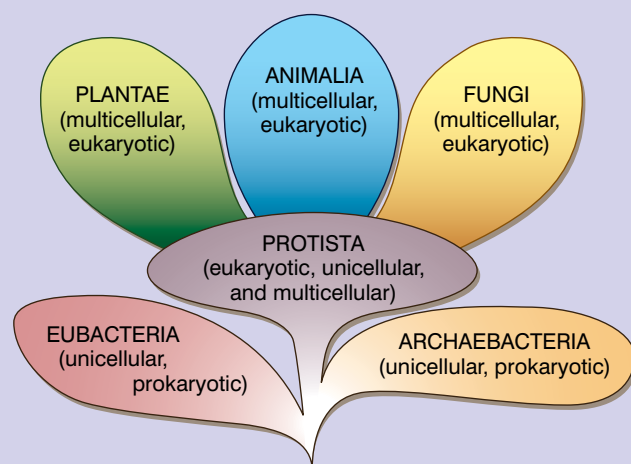
**autotrophic** autotrophic cells are capable of making their own organic molecules from inorganic ones, usually by photosynthesis

**endosymbiont theory** theory of the origin of eukaryotic cells

**DID YOU KNOW?**

**Which organisms have eukaryotic cells and which have prokaryotic cells?**

Figure 4.18 shows the main groups of living things and which of these have prokaryotic and which have eukaryotic cells. The **archaebacteria** are thought to be the oldest organisms on Earth. They evolved when conditions on Earth were very harsh and are still only found where it is very hot, or where there are large concentrations of gases like methane or sulphur dioxide. The **eubacteria** are what you and I really mean when we talk about bacteria. These are the bacteria that inhabit our intestines, decay organisms, convert milk to yoghurt and so on.



**Figure 4.18** The main groups of living things

**Activity 4.5**

Make a table to compare and contrast the main features of eukaryotic and prokaryotic cells.

**What are the differences between prokaryotic and eukaryotic cells?**

**Table 4.2** A summary of the main differences between prokaryotic and eukaryotic cells

Feature	Prokaryotic cells	Eukaryotic cells
Size	1–10 $\mu\text{m}$	10–100 $\mu\text{m}$
Nucleus	No membrane-bound nucleus	Nucleus surrounded by nuclear envelope
DNA	<ul style="list-style-type: none"> <li>In a continuous loop</li> <li>Not associated with protein to form chromosomes</li> </ul>	<ul style="list-style-type: none"> <li>Linear DNA</li> <li>Associated with histone proteins in chromosomes</li> </ul>
Mitochondria	Absent	Present
Chloroplasts	Absent (but some prokaryotic cells contain a kind of chlorophyll and can photosynthesise)	Present in some cells (some plant cells and some algal cells)
Ribosomes	Present, but smaller than in eukaryotic cells ( <b>70S</b> )	Present, but larger than in prokaryotic cells ( <b>80S</b> )
Cell wall	<ul style="list-style-type: none"> <li>Always present</li> <li>Not made from cellulose (often made from peptidoglycan)</li> </ul>	<ul style="list-style-type: none"> <li>Present in plant cells, algal cells and fungal cells</li> <li>Cellulose in plant cells, various materials in other cells</li> </ul>

**KEY WORDS**

**70S and 80S ribosomes** the 'S' stands for 'sedimentation coefficient' and is a measure of their mass

**Review questions**

Choose the correct answer from A to D.

- Differences between prokaryotic and eukaryotic cells are:
  - prokaryotic cells are smaller but contain more organelles
  - prokaryotic cells are larger and contain more organelles
  - prokaryotic cells are larger and contain fewer organelles
  - prokaryotic cells are smaller and contain fewer organelles
- The DNA in prokaryotic cells is:
  - linear and bound with proteins
  - linear and not bound with proteins
  - circular and not bound with proteins
  - circular and bound with proteins



3. Membrane-bound organelles include:
- A ribosomes and mitochondria
  - B mitochondria and chloroplasts
  - C chloroplasts and peroxisomes
  - D peroxisomes and nuclei
4. The cell wall of prokaryotic cells is made from:
- A protein
  - B cellulose
  - C peptidoglycan
  - D another substance
5. It is thought that eukaryotic cells originated by several prokaryotic cells becoming associated. This theory is the:
- A endosymbiont theory
  - B membrane association theory
  - C both of the above
  - D neither of the above

### 4.3 Parts of the cell and their functions

By the end of this section you should be able to:

- Discuss the importance of a cell membrane.
- Describe the composition and arrangement of lipids and proteins in the membrane.
- Compare the Davson–Danielli and fluid mosaic models.
- Construct and show the arrangement of the phospholipids and proteins in the fluid mosaic model.
- Explain the role of glycoprotein and other components in the cell membrane.
- Name the different parts of the cell and explain their functions.
- State and explain the mechanisms of substance transport across a cell membrane.
- Conduct an experiment to show movement of solvent through a semi-permeable membrane.
- Demonstrate osmosis at a semi-permeable membrane.
- Explain that the size of a cell changes by osmosis because of the inflow and outflow of water.
- Appreciate that osmosis is responsible for everyday life phenomena.

**KEY IDEA**

*The cell's environment could be fluids inside the body of an animal, plant, fungus or alga, or it could be the ocean, a river, a pond, soil or just about anything you care to think of! The plasma membrane of a cell must isolate the cell from that environment, but, at the same time, allow exchange with the environment.*

**What is the importance of the cell membrane?**

The membrane that surrounds and encloses a cell is sometimes called the **cell surface membrane**, but most biologists now refer to it as the **plasma membrane**. Although this membrane has little mechanical strength to support the cell, it plays a crucial role in:

- controlling what enters and leaves the cell; the plasma membrane moves substances in and out of the cell by:
  - simple diffusion
  - facilitated diffusion
  - osmosis
  - active transport
  - endocytosis
  - exocytosis
- cell signalling; various molecules in the membrane allow the cell to be recognised by hormones and the immune system (in animals) and (in plants) growth regulator substances, such as auxins.

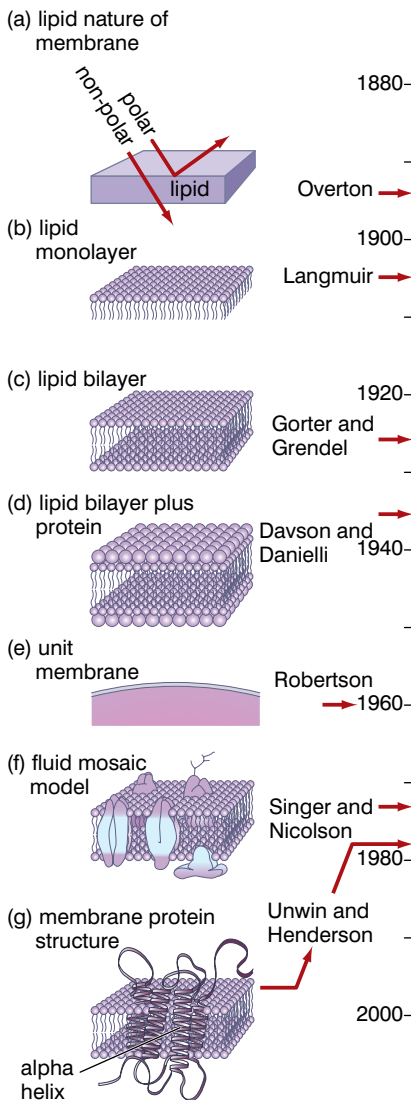
The plasma membrane clearly has a vital role in isolating the cell from its environment, whilst allowing necessary exchanges with that environment.

**What is the plasma membrane like?**

We already found out in unit 2 that the basis of plasma membranes is a phospholipid bilayer. But a plasma membrane is much more complex than a simple bilayer. There have been several models of the structure of the plasma membrane. Table 4.3 shows some key events in developing the current model of membrane structure. Figure 4.19 illustrates this history.

**Table 4.3** Key events

Year	Event
1665	Robert Hooke discovers cells, but only sees dead cells and has no idea of a cell membrane.
1895	Charles Overton shows that the cell membrane is composed of some kind of lipids.
1905	Langmuir proposes a lipid monolayer as the basic membrane structure.
1910–1920	Evidence accumulates to show that the lipid in the membrane must be a phospholipid.
1925	E Gorter and G Grendel suggest that the plasma membrane is a phospholipid bilayer.
1935	Davson and Danielli know that proteins are also found in plasma membranes and suggest a 'sandwich' model.
1959	Based on electron microscope evidence that appears to support the Davson–Danielli model, J D Robertson proposes the unit membrane model – he suggests that all membranes are essentially the same.

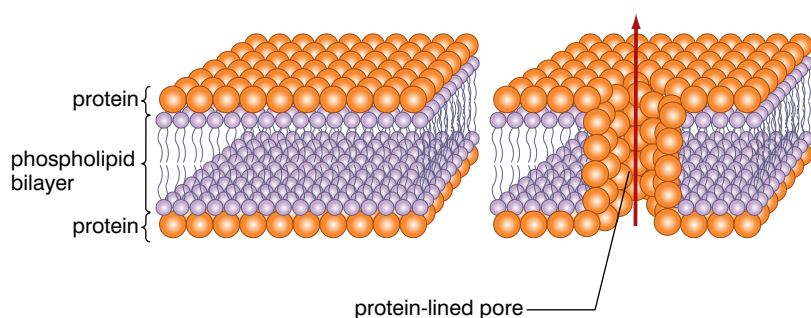


**Figure 4.19** A timeline of the development of our understanding of the structure of the plasma membrane

Year	Event
1972	S J Singer and G L Nicholson propose the fluid mosaic model of membrane structure. As more and more supporting evidence accumulates, this is essentially the model we accept today.

### The Davson–Danielli model

In 1935, Davson and Danielli knew that both proteins and phospholipids were involved in the structure of plasma membranes. Without any direct observational evidence to assist them (the very first electron microscopes were only just being built and they could not reveal membrane structure) Davson and Danielli suggested a kind of ‘sandwich’ of protein and phospholipid.



**Figure 4.20** The Davson–Danielli models of 1935 and 1954

This was based on what they knew of the proportions of the two substances in the membrane. The protein was to form the ‘bread’ of the sandwich with the phospholipid forming the ‘filling’. In 1954 they proposed a revised model in which they included protein-lined pores. Figure 4.20 shows the Davson–Danielli models of 1935 and 1954.

As more and more evidence accumulated about how molecules moved across membranes, it became clear that the Davson–Danielli model could not adequately explain all the new evidence. The model therefore had to be rejected.

In 1972, Singer and Nicholson proposed a totally different arrangement of the phospholipids and proteins in the plasma membrane. They retained the idea of a phospholipid bilayer, but rejected the sandwich arrangement. Instead, they suggested that proteins were ‘studded’ into the bilayer at different points. They also suggested that the arrangement was not static, but was fluid and constantly changing. Figure 4.21 shows the difference between the Davson–Danielli model and the original fluid mosaic model.

### KEY IDEA

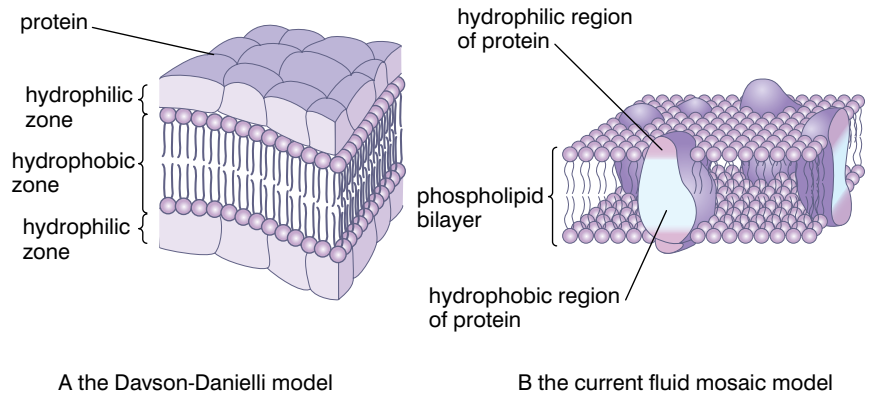
#### Scientific models

*Models such as the Davson–Danielli membrane model and the fluid mosaic model are very important in science. But why do we call it a model, and what are scientific models?*

- *Models are conceptual plans of some system that try to explain experimental observations and relate the various observations to each other.*
- *A good model incorporates what is known about some concept and adds in the best guesses about missing parts.*
- *A good model will allow you to make predictions about some aspect of the way in which a system works that can be tested experimentally.*
- *Models may, therefore, turn out to be wrong, if the evidence from experiments does not match the predictions. Even so, the model will have served a valuable purpose in eliminating one possible idea and, perhaps, hinting at how to change the model to explain the system we are interested in.*
- *As more evidence accumulates to support a model, it becomes accepted by scientists as the best explanation for the system they are investigating.*

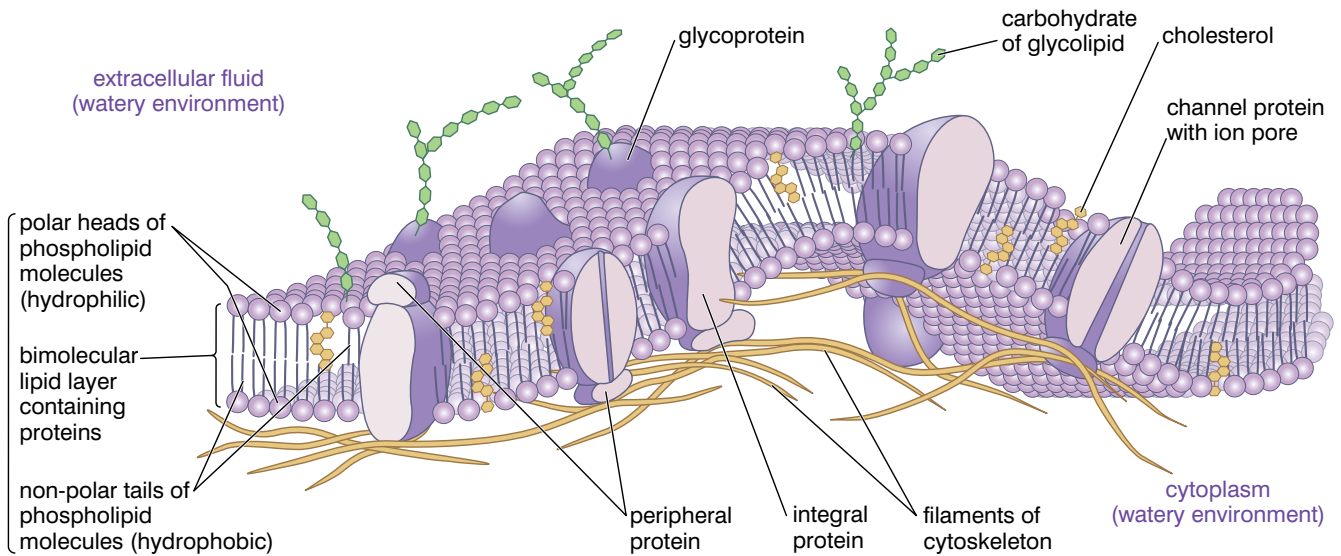
### KEY WORDS

**plasma membrane/cell surface membrane** *the membrane at the surface of all cells that isolates the cell from the environment and controls the exchange of substances between cell and environment*



**Figure 4.21** The Davson–Danielli model and the fluid mosaic model

As our understanding of processes that occur at the plasma membrane has increased and we have learned more of cell structure and function, the fluid mosaic model has become more sophisticated. Our current idea of membrane structure still assumes this fluid-mosaic nature, but there is now much more detail to the model, as figure 4.22 shows.



**Figure 4.22** The current fluid mosaic model of membrane structure

The key features of the model as we currently understand it are:

- The phospholipid bilayer as the basis for the membrane
- **Integral proteins** (also known as intrinsic proteins and trans-membrane proteins) that span the membrane. Some of these proteins play an important role in moving substances across the membrane. There are three main types of these transport proteins:
  - **channel proteins** – these proteins have a channel through them along which a specific ion can pass; there are different channel proteins for different ions
  - **carrier proteins** – these proteins act in a more sophisticated way to move larger molecules through the membrane by facilitated diffusion or active transport; the ones involved in active transport are often referred to as pumps

**KEY WORDS**

**integral proteins** proteins that span both phospholipid layers in a plasma membrane

**channel proteins** integral proteins with pores that allow ions to pass through the membrane

**carrier proteins** integral proteins that move medium-sized particles across the membrane

- **peripheral proteins** (also known as extrinsic proteins) that span only one layer (or sometimes less) of the membrane. They have a range of functions; some are enzymes, others anchor integral proteins to the cytoskeleton
- **Glycoproteins** and glycolipids – protein and lipid molecules that have carbohydrate chains attached to them and often serve as signals to other cells. They also act as receptor sites for hormones and drugs. The carbohydrate component of each can be cell-specific and so allow identification of the cell by the immune system.
- **Cholesterol** – reduces the fluidity of the membrane.

**DID YOU KNOW?****Receptors are the ‘way in’ for unwanted substances**

Some viruses are able to bind with some of the receptors on the plasma membrane and gain entry to the cell as a consequence. Some bacterial toxins enter in the same way.

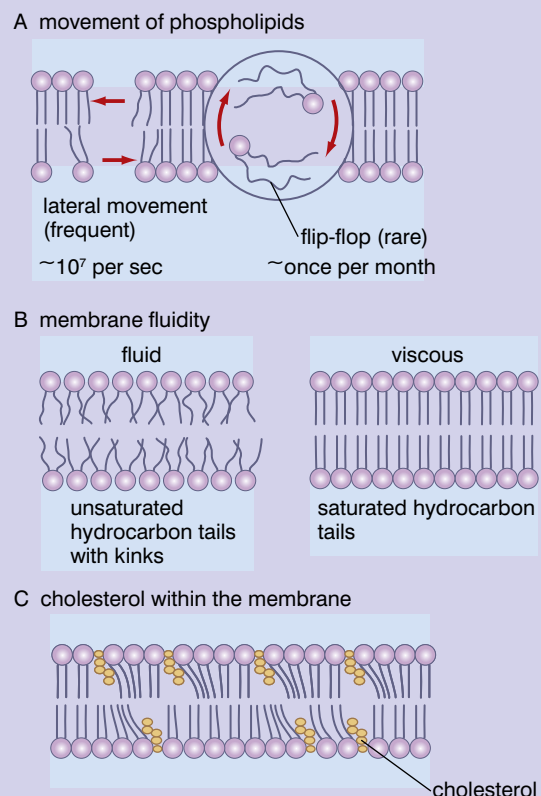
**DID YOU KNOW?****Why is the fluid mosaic model called the fluid mosaic model?**

It is fluid mainly because the phospholipids in the membrane can move and change position. Figure 4.23 shows some ways in which they do this.

The nature of the fatty acids (saturated or unsaturated) and the amount of cholesterol in the membrane both influence the fluidity of the membrane.

The ‘mosaic’ part of the name comes from the way the proteins in the membrane give a patchwork appearance when viewed from the inside or outside. This is rather like a mosaic.

**Figure 4.23** Fluidity of the plasma membrane

**How do substances cross the plasma membrane?**

Not all particles can actually pass through a plasma membrane unaided. This is because of the largely lipid nature of the membrane. To pass through the plasma membrane by simple diffusion particles must be:

- small
- lipid soluble
- non-charged

This excludes particles such as ions (they are charged), sugars and amino acids (they are not lipid soluble and are not small particles) and any of the really large particles, such as proteins.

**KEY WORDS**

**peripheral proteins** proteins that span only one of the two phospholipid layers

**glycoproteins** proteins with chains of sugars attached

**cholesterol** a sterol lipid

We can group the processes by which substances cross plasma membranes into two main types:

- **passive processes** – these processes rely only on the kinetic energy of the particles of the substances and on concentration gradients; they need no extra energy from the cell's metabolism
- **active processes** – these require energy from the cell's metabolism in the form of ATP to drive the transport.

Table 4.4 summarises the transport processes.

**Table 4.4** *The transport process*

Passive processes		Active processes	
Process	Brief description	Process	Brief description
Simple diffusion	Particles move from a high concentration to a low concentration.	Active transport	Particles move from a low concentration to a higher concentration using a carrier protein (pump).
Facilitated diffusion	Particles move from a high concentration to a low concentration through an ion pore or carrier protein.	Endocytosis	Large particles are engulfed by the plasma membrane invaginating and forming a vesicle.
Osmosis	Water molecules move from a high water potential to a lower one.	Exocytosis	Large particles are secreted by a vesicle in the cell merging with the plasma membrane to release the substance.

### Activity 4.6

Work in groups. EITHER make a big poster to show the fluid mosaic model of the structure of the membrane of a eukaryotic cell OR make a 3-D model of the fluid mosaic model of the structure of the membrane of a eukaryotic cell.

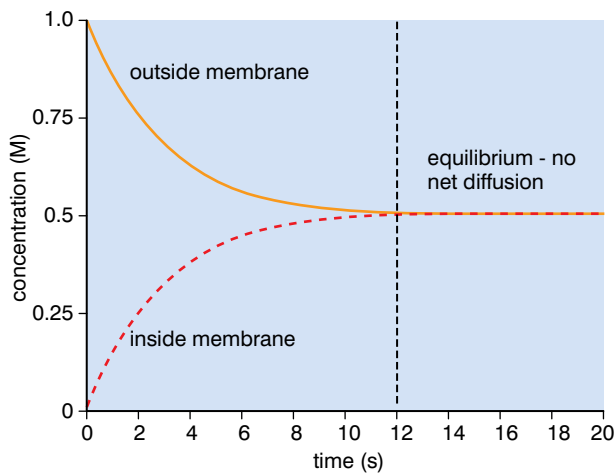
### Passive processes

#### Simple diffusion

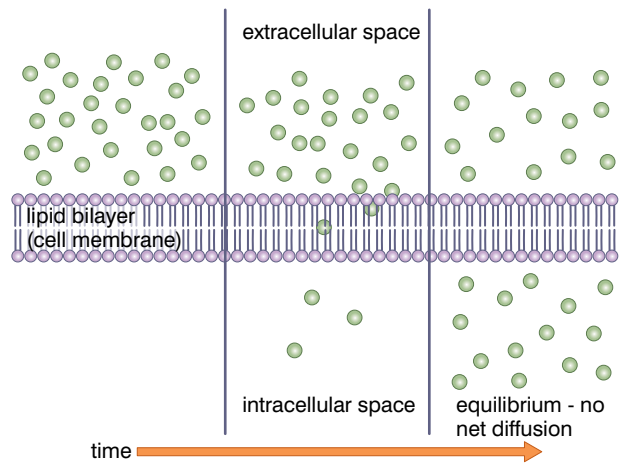
In fluids – liquids and gases – the particles that make up the fluid are free to move around. This kinetic energy is what drives diffusion. If particles are, for some reason, concentrated in a small area, they will move in such a way that the particles ‘spread out’ and occupy all the space that is available to them. This is a result of random particular motion. Diffusion need not involve a membrane.

When particles diffuse across a plasma membrane, there must be a concentration difference between the two sides of the membrane (a concentration gradient) to drive the process. As diffusion proceeds, the high concentration will decrease and the low concentration will increase until the two concentrations are the same. At this point there will be no further net diffusion.

This means that although particles will still move across the membrane, they will move equally in both directions, so there will be no overall effect. We say that the concentrations are in equilibrium. Figures 4.24 and 4.25 show this.



**Figure 4.24** The change in concentrations as diffusion proceeds



**Figure 4.25** The change in concentrations across a membrane as diffusion proceeds

The rate at which diffusion across a membrane takes place is influenced by:

- the concentration gradient – a bigger difference in concentration results in faster diffusion than a smaller gradient
- the thickness of the membrane – as all plasma membranes are the same thickness, this is not really an issue when considering diffusion into and out of cells, but for other situations where particles must cross some kind of barrier, a shorter distance results in faster diffusion
- the surface area of the membrane – clearly if there is more membrane where diffusion can take place, diffusion will happen faster

These features are all related in an equation called Fick's law of diffusion:

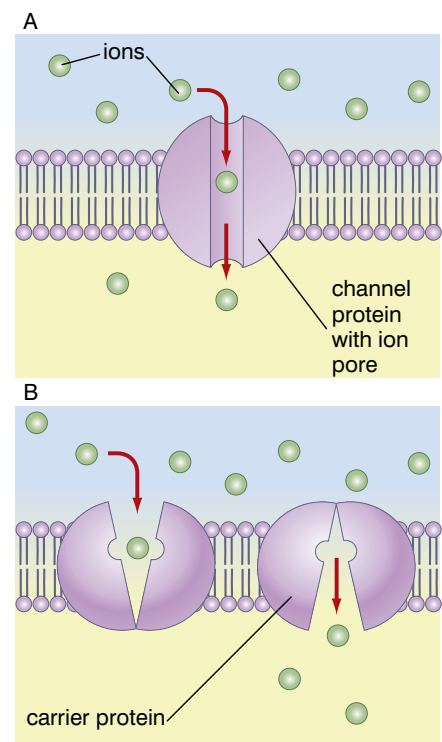
$$\text{Rate of diffusion} \propto \frac{\text{Surface area of membrane} \times \text{Concentration difference}}{\text{Diffusion distance}}$$

The rate of diffusion is also influenced by temperature. Diffusion occurs faster at higher temperatures because the particles have more kinetic energy and so move faster.

### Facilitated diffusion

Facilitated diffusion is essentially the same process as diffusion, in that it depends on a concentration gradient to allow particles to cross the membrane. However, it differs in that the particles must be helped to diffuse across the membrane (their diffusion must be 'facilitated') by a carrier protein or a channel protein with an ion pore. Figure 4.26A shows facilitated diffusion of an ion through an ion pore. Figure 4.26B shows a carrier protein moving particles across a membrane.

Note in both cases that the particles are moving from a high concentration to a low concentration (as with simple diffusion).



**Figure 4.26** Facilitated diffusion through A an ion pore and B a carrier protein.

**DID YOU KNOW?**

**Saturation of carrier proteins**

Although increasing the concentration gradient will increase the rate of both simple diffusion and facilitated diffusion, a point will come with facilitated diffusion when all the carrier proteins are transferring particles as fast as they can. At this point we say that the carrier proteins are saturated and facilitated diffusion can go no faster.

However, also note that whilst the ions can simply move straight through the ion pore of a channel protein, the carrier protein must undergo a conformational change (change in shape) to move particles through the membrane.

The rate of facilitated diffusion is affected by the same factors that affect simple diffusion with the exception that it is not the actual surface area of the membrane that determines the rate, but the number of carrier proteins (or channel proteins) present.

**Osmosis**

Osmosis is the process by which water moves across a partially permeable membrane. It is, effectively, the diffusion of water. However, we do not refer to the concentration of water molecules, but to **water potential**. We can say that osmosis is the movement of water from a system with a high water potential to a system with a low water potential across a partially permeable membrane.

The symbol for water potential is the Greek letter  $\Psi$  (psi). Water potential is measured in units of pressure – pascals (Pa), kilopascals (kPa) or megapascals (MPa). Pure, liquid water has a higher water potential than any other system. It is defined as zero:

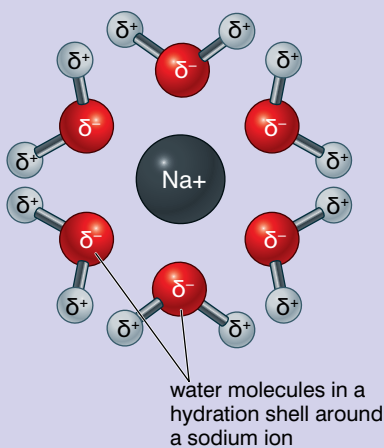
$$\Psi (\text{pure water}) = 0 \text{ Pa}$$

All other systems (cells, solutions and suspensions) have a water potential that is lower than that of water. Therefore, their water potential values must be negative. So we can define osmosis more accurately as follows:

*Osmosis is the movement of water from a system with a high (less negative) water potential to one with a lower (more negative) water potential, across a partially permeable membrane.*

**KEY WORD**

**water potential** *the concentration of water molecules*



**Figure 4.27** Adding a solute reduces the water potential of a system

**DID YOU KNOW?**

**Why water potential values are negative**

The water potential of a system is due to the concentration of free water molecules in that system. In pure water, there are only water molecules. When a solute is added, some of the water molecules form 'hydration shells' around the solute molecules. This reduces the number of (free) water molecules in the system and so the water potential is reduced. Since pure water is assigned a water potential of zero, the solution must have a negative water potential. A more concentrated solution will take more free water molecules out of the system and lower the water potential still further, making it more negative.



The rate at which osmosis proceeds is influenced by the same factors as simple diffusion:

- surface area of the membrane
- difference in water potential
- distance the molecules must travel

*What happens to cells placed in solutions of different concentrations?*

This depends on what type of cell. Animal cells have no cell wall, whereas plant cells do and this has a significant influence on the outcome. The difference in water potential between cell and solution will determine whether water enters or leaves by osmosis.

When comparing the water potential of a solution to that of a cell, we could describe it as:

**isotonic** – having the same water potential as the cell

**hypertonic** – having a lower (more negative) water potential than the cell

**hypotonic** – having a higher (less negative) water potential than the cell

### KEY WORDS

**isotonic** solution having the same water potential as the cell

**hypertonic** solution having lower water potential than the cell

**hypotonic** solution having a higher water potential than the cell

### Activity 4.7: Osmosis in an Egg

In this investigation, you will use a hen's egg which has had the shell removed by soaking in vinegar (the acid in the vinegar dissolves the calcium carbonate that makes up the shell)

#### You will need:

- 1-2 fresh hen eggs (shells removed)
- masking tape & marker
- distilled water,
- concentrated salt (sodium chloride) solution
- clear jar with lid,
- tongs,
- electronic balance,

#### Procedure:

- use tongs to *carefully* remove an egg to a paper towel & pat it dry.
- record the size & appearance of your egg in a table
- place the egg on an electronic balance & record
- *carefully* place the egg into the jar and cover the egg with distilled water
- loosely re-cap the jar & allow it to sit for 24 hours
- repeat the procedure with another egg, but cover this egg in concentrated sodium chloride solution (rather than distilled water)
- open the jars & discard the distilled water/sodium chloride solution
- use tongs to carefully remove the eggs to a paper towel and pat them dry
- record the size & appearance of the eggs in your data table.
- weigh the egg on an electronic balance & record the mass in your table

What happened to:

- the size of the egg
- the mass of the egg

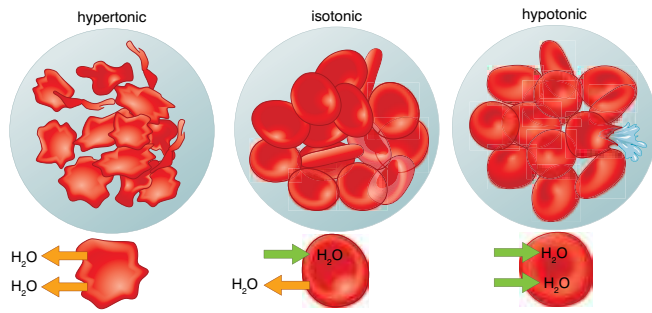
after soaking in:

- distilled water?
- concentrated sodium chloride solution?

Explain these changes using your knowledge of osmosis.

#### Results table

Solution used	Original mass / g	Final mass / g	Size and appearance of egg
Distilled water			
Concentrated salt			



**Figure 4.28** The effect of different solutions on red blood cells

**Animal cells**

Figure 4.28 shows what happens when red blood cells are placed in different solutions.

In the hypertonic solution, the cells lose water by osmosis and shrink.

In the hypotonic solution, the cells gain water by osmosis and swell. The pressure will eventually burst the weak plasma membrane: this is called haemolysis.

There is no change in the isotonic solution.

**Plant cells**

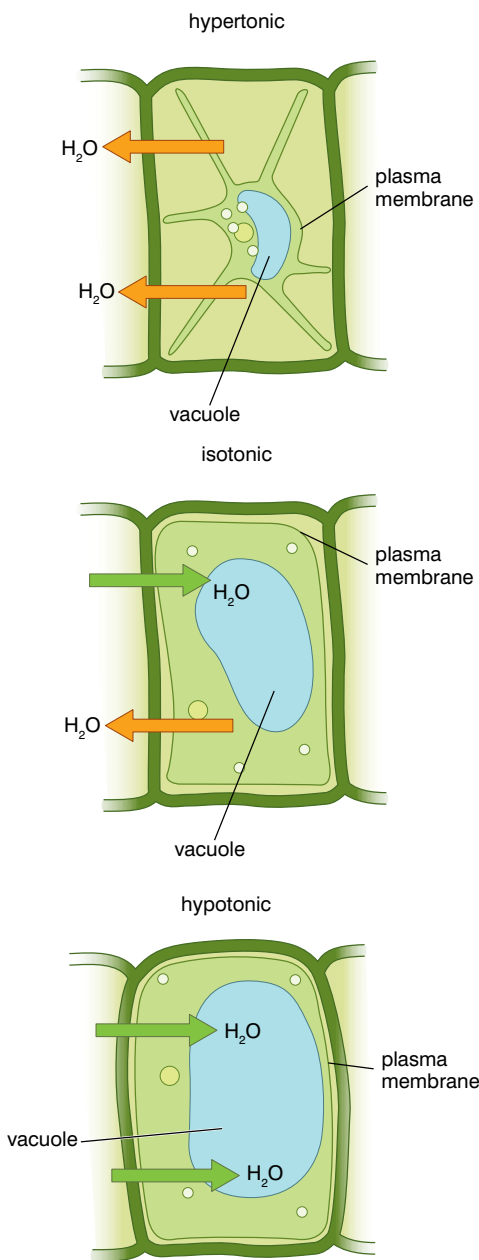
Figure 4.29 shows what happens when plant cells are placed in different solutions.

In the hypertonic solution, the cytoplasm of the cells loses water by osmosis and shrinks. Because of this, there is no pressure from the cytoplasm on the cell wall. The cell is said to be flaccid. If the cytoplasm shrinks too much, it loses contact with the cell wall and we say the cell has been plasmolysed.

In the hypotonic solution, the cells gain water by osmosis and swell. However, because of the cell wall, the cell cannot become much larger. Plant cells in this condition are turgid.

There is no change in the isotonic solution.

Turgidity is important in supporting young, non-woody plant stems. If the plant is kept well watered, the cells will remain turgid. The turgid cells will press against each other and this pressure will keep the plant upright. If the plant is not watered, the cells will be plasmolysed and become flaccid. They will no longer press against each other and the support will be lost. The plant will wilt.

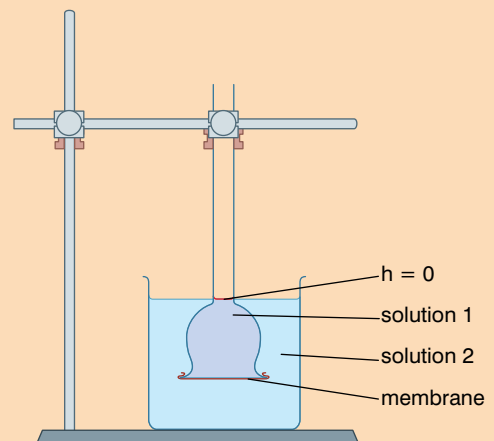


**Figure 4.29** The effect of different solutions on plant cells

**Activity 4.8: Investigation showing the pressure generated by different solutions**

**You will need:**

- a thistle funnel
- clamp and stand
- cellophane to act as the membrane
- distilled water
- 0.2M, 0.4M, 0.6M, 0.8M and 1.0M solutions of sucrose
- a ruler



**Figure 4.30** Investigating the osmotic pressure generated by different solutions

**Method**

1. Set up the apparatus as shown with distilled water on both sides of the membrane.
2. Leave for 30 minutes.
3. Measure the increase in height of the water inside the thistle funnel.
4. Repeat with 0.2M, 0.4M, 0.6M, 0.8M and 1.0M solutions of sucrose inside the membrane (solution 1) and distilled water outside the membrane (solution 2).
5. Plot a graph of your results.
6. What conclusion can you draw?



**Figure 4.31** The effect of watering a plant

**Activity 4.9: Finding the water potential of potato cells****Method**

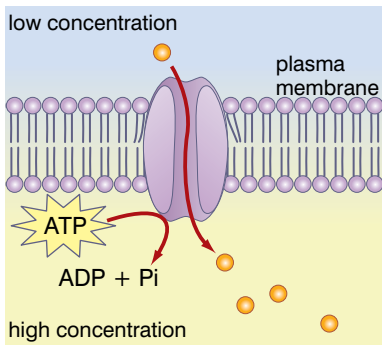
1. Collect about 100 cm<sup>3</sup> 1M sucrose and 100 cm<sup>3</sup> water in separate beakers.
2. Label six boiling tubes A–F.
3. Make up dilutions of the 1M sucrose solution supplied as below. Use a separate 10 cm<sup>3</sup> syringe for the water and for the sucrose.

Tube	Amount of sucrose/cm <sup>3</sup>	Amount of water/cm <sup>3</sup>	Final concentration/M
A	20	0	1.0
B	16	4	0.8
C	12	8	0.6
D	8	12	0.4
E	4	16	0.2
F	0	20	0.0

4. Prepare a table for your results; you will need columns for initial mass, final mass, change in mass and % change in mass.

Solution	Mass at the start/g	Mass at the end /g	Change in mass /g	% Change in mass
Distilled water				
0.2M sucrose				
0.4M sucrose				
0.6M sucrose				
0.8M sucrose				
1.0M sucrose				

5. Using a cork borer obtain six cylinders of potato tissue.
6. Trim each to a length of 5 cm. Cut off any 'skin' from the ends.
7. Roll each on absorbent paper to remove any surface water.
8. Weigh each and note the mass.
9. Place each cylinder in one of the solutions and leave for 30 minutes.
10. Remove each from the solution; roll each on absorbent paper to remove any surface water and reweigh.
11. Calculate the % change in mass for each.
12. Plot a graph of % change in mass against molarity and use the graph to estimate the molarity of the solution that has the same water potential as the potato cells.



**Figure 4.32** Active transport

## Active processes

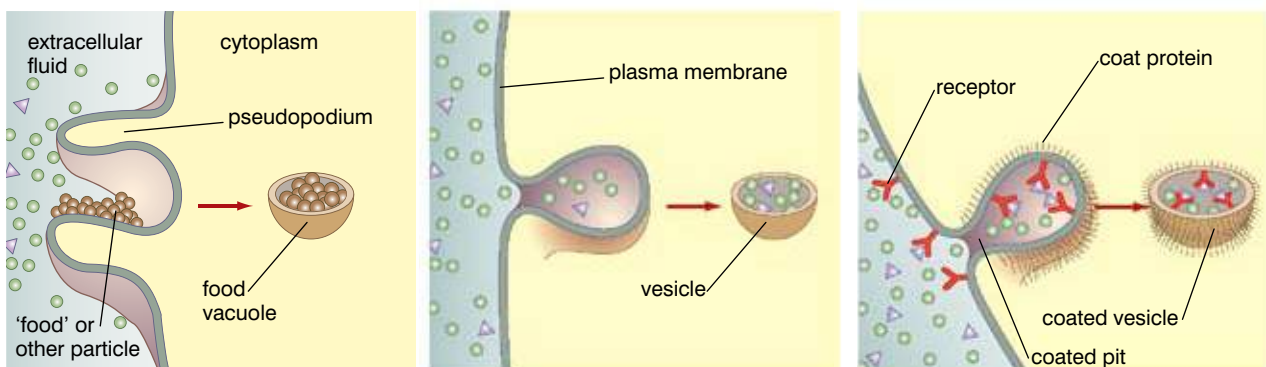
### Active transport

Sometimes, substances must be moved against a concentration gradient – from a low concentration to a higher one. This cannot happen by diffusion, since it would tend to concentrate particles rather than spread them out. It can only happen if metabolic energy is used to drive the process. In living organisms, this energy is released from the ATP produced in respiration. When the energy is released from ATP, it is broken down into ADP and P<sub>i</sub> (inorganic phosphate). The proteins used to actively transport substances across plasma membranes are called pumps.

### Endocytosis

In this process, large particles are engulfed by a cell. There are several ways in which it can happen, but, essentially, part of the plasma membrane surrounds the particles to form a vesicle which is then processed by the cell. Figure 4.33 shows three different types of endocytosis. All of them require ATP to move the membrane around the particles to form the vesicle.

**Figure 4.33** Endocytosis can occur in a number of ways.



A phagocytosis

B pinocytosis

C receptor-mediated endocytosis

### Phagocytosis

This involves the creation of pseudopodia (extensions of the plasma membrane) to enclose large particles or even whole organisms outside the cell. Once enclosed by the pseudopodia, they form an internal vesicle which is then moved further inside the cell.

### Pinocytosis

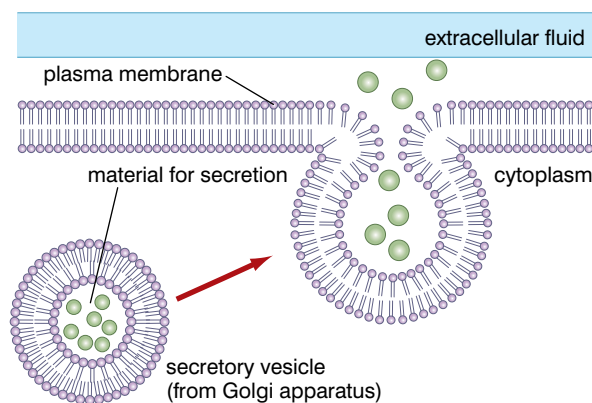
This differs from phagocytosis only in scale. It involves the ingestion of smaller particles (but particles that are still too large to cross the membrane by other methods) and does not require the formation of large pseudopodia to engulf the particles.

### Receptor-mediated endocytosis

The membrane infolds to form vesicles only in regions where particles have bound to specific receptors. The binding stimulates the infolding.

## Exocytosis

In this process, substances are moved from the inside to the outside of the cell in what is, effectively, the reverse of endocytosis. It is the process by which enzymes and hormones are secreted. Again, ATP is used to alter the configuration of the membrane.



**Table 4.5** The transport processes compared

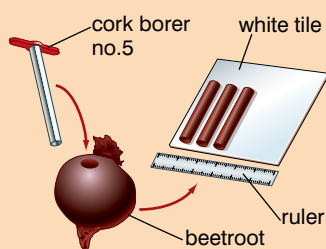
**Figure 4.34** Exocytosis

Process	Influence of concentration	Requirement for ATP?	Type of particles moved	Transport proteins needed?
Simple diffusion	Occurs from high to low	No	Lipid-soluble, small, non-polar	No
Facilitated diffusion	Occurs from high to low	No	Ions and medium-sized particles	No
Osmosis	Occurs from high to low (water potential)	No	Water molecules	No
Active transport	Occurs from low to high	Yes	Ions and medium-sized, non-lipid-soluble particles	Yes
Endocytosis	Can occur either way	Yes	Very large particles	Yes
Exocytosis	Can occur either way	Yes	Very large particles	Yes

### Activity 4.10: How does temperature affect the permeability of a plasma membrane?

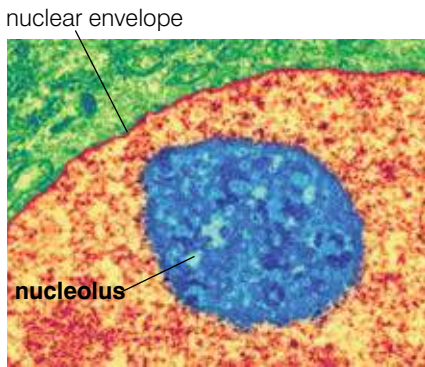
#### Method

- Set up water baths at 20 °C, 30 °C, 40 °C, 50 °C, 60 °C and 70 °C.
- Using a cork borer, obtain 10 cylinders from beetroot (you may have to use more than one).
- Cut off the 'skin' at the ends.
- Cut each into 1 cm lengths – you will need 30.
- Place them in a beaker and rinse under running water until the water no longer shows any colouration.

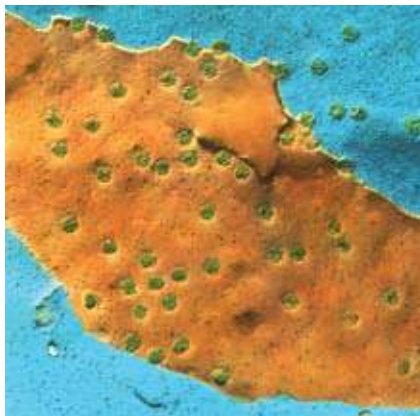


- Place 10 cm<sup>3</sup> water into each of six boiling tubes; label them 20 °C, 30 °C, 40 °C, 50 °C, 60 °C and 70 °C.
- Stand each in the appropriate water bath for five minutes to equilibrate to temperature.
- Add five beetroot discs to each tube and leave for 15 minutes (**still in the water bath**). Start to clear away whilst you are waiting.
- After 10 minutes, remove the tubes and shake them for 10 seconds to distribute any pigment.
- Transfer a sample of the liquid to a cuvette.
- Obtain a reading of absorbance for each sample. Remember to zero the colorimeter with a reference cuvette of distilled water each time.
- Record your results in a table then use them to plot a line graph. Explain your results using your knowledge of membrane structure.

**DO NOT PUT THE BEETROOT IN THE BOILING TUBES YET.**



**Figure 4.35** An electron-micrograph of the nucleus



**Figure 4.36** An electron-micrograph showing pores in the nuclear membrane

**KEY WORDS**

**cristae** partial partitions in mitochondria

**fluid matrix** where some of the reactions of aerobic respiration take place in mitochondria

**DID YOU KNOW?**

ATP is the ‘energy storage molecule’ of cells. Energy released in respiration is stored in ATP molecules, to be released and used when needed. Cells that are very active (such as muscle cells or epithelial cells that absorb molecules from the gut) use a great deal of ATP and, therefore, contain many mitochondria.

**The other cell organelles – what are they like and what do they do?**

In this section, we will discuss the other organelles in outline only. We shall discover their functions in more detail as we discuss the metabolic processes they carry out.

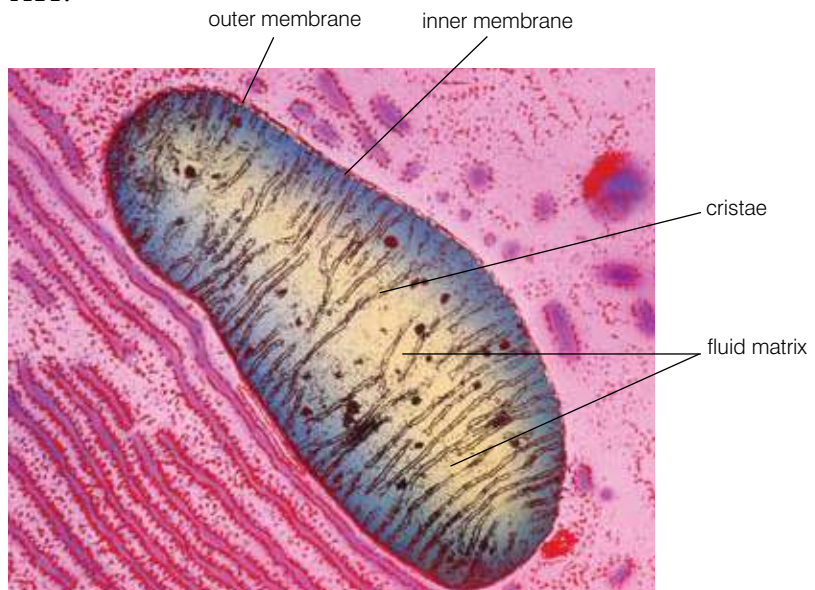
**The nucleus**

The nucleus typically occupies about 10% of the volume of a cell. It has several components:

- The nuclear envelope is a double membrane that surrounds the nucleus. There are many nuclear pores, which allow the passage of some molecules between the nucleus and the cytoplasm.
- The nucleolus is an organelle within the nucleus. It is not membrane-bound. Its function is to synthesise the components of ribosomes, which then pass through the nuclear pores into the cytoplasm.
- Chromatin consists of DNA molecules bound with proteins called histones. For most of the cell cycle, the chromatin fibres are loosely dispersed throughout the nucleus. Just before a cell is about to divide, the chromatin condenses into distinct, recognisable structures called chromosomes.

**Mitochondria**

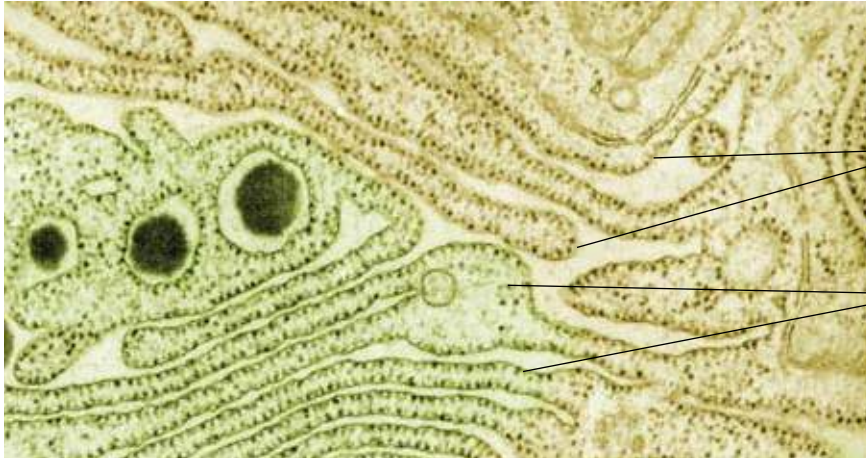
Mitochondria are the sites of most of the reactions of aerobic respiration. They are surrounded by two membranes. The inner membrane is folded into **cristae** to increase the available surface area. Some of the reactions of aerobic respiration take place in the **fluid matrix**. The folded inner membrane provides a large surface area for the electron-transport system, which produces most of the ATP.



**Figure 4.37** An electron-micrograph of a mitochondrion

## Ribosomes

Ribosomes are the sites of protein synthesis. They can be found free in the cytoplasm, but are also bound to the membrane system of the endoplasmic reticulum, forming rough endoplasmic reticulum. Each ribosome comprises two subunits that are made from RNA and protein. The subunits are manufactured in the nucleolus. They leave the nucleus through nuclear pores and combine in the cytoplasm.



**Figure 4.38** Rough endoplasmic reticulum with ribosomes attached

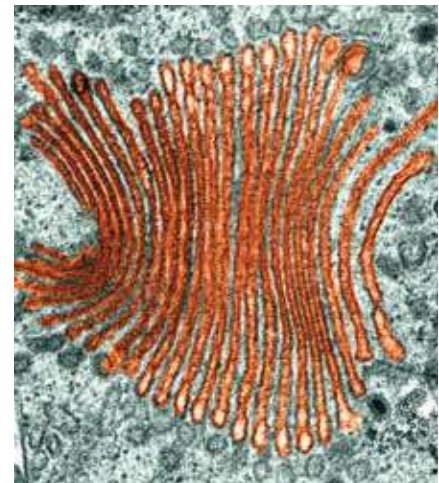
endoplasmic reticulum

ribosomes

## Endoplasmic reticulum

Endoplasmic reticulum (ER) is a membrane system found throughout the cytoplasm of eukaryotic cells. There are two types of endoplasmic reticulum:

- **Rough ER** has ribosomes on its surface and is responsible for the manufacture and transport of proteins. Protein molecules manufactured by the ribosomes pass through small pores into the lumen (inner space) of the ER. They are then moved in a vesicle to the Golgi body. Rough ER is extensive in cells that manufacture a lot of protein, such as cells that manufacture enzymes to be secreted into the lumen of the intestine.
- **Smooth ER** has no ribosomes on its surface. It is concerned with the synthesis of lipids. It is also associated with carbohydrate metabolism and detoxification.



**Figure 4.39** An electron-micrograph of the Golgi apparatus

## Golgi apparatus (or Golgi body)

The Golgi apparatus consists of a number of flattened membrane-bound sacs in which proteins are modified. Proteins may be converted into glycoproteins, for example. Many of the modifications added in the Golgi apparatus act as a kind of 'tag', which determine the final destination of the molecule. Think of the Golgi apparatus as a cellular post office that labels and then distributes molecules!

Many of the modified molecules are released from the Golgi apparatus in vesicles to be carried to other parts of the cell or to the plasma membrane to pass out of the cell by exocytosis to be used elsewhere. Some vesicles form the lysosomes.



**Figure 4.40** An artist's impression of the Golgi apparatus

**KEY WORDS**

**grana** *membranous regions in a chloroplast*

**thylakoids** *flattened sacs inside a chloroplast where photosynthesis takes place*

**Lysosomes**

Lysosomes have no specialised internal structure and are surrounded by a single membrane. They are formed in the Golgi apparatus and contain digestive enzymes that break down cellular waste and debris. Lysosomes are particularly abundant in phagocytic white blood cells. Here, enzymes from the lysosomes digest foreign cells that have been engulfed.

The organelles we have described so far are found in all eukaryotic cells. However, not all eukaryotic cells are the same. In particular, there are important differences between plant and animal cells.

**Organelles found in plant cells****Cell wall**

We have studied the molecular structure of the cell wall in unit 2. The criss-cross arrangement of cellulose fibres in the cell wall gives it both strength and elasticity. Because there are large 'gaps' (on a molecular scale) between the fibres, the cell wall is freely permeable.

**Vacuole**

The vacuole in a plant cell is a fluid-filled sac that stores a range of solutes. It is also important in maintaining the turgidity, or turgor, of a cell. When the vacuole is full of liquid (mainly water), it exerts pressure on the cytoplasm and, in turn, on the cell wall. If the vacuole loses water by osmosis, the pressure reduces and turgor is lost. The cell becomes flaccid (see the section on osmosis).

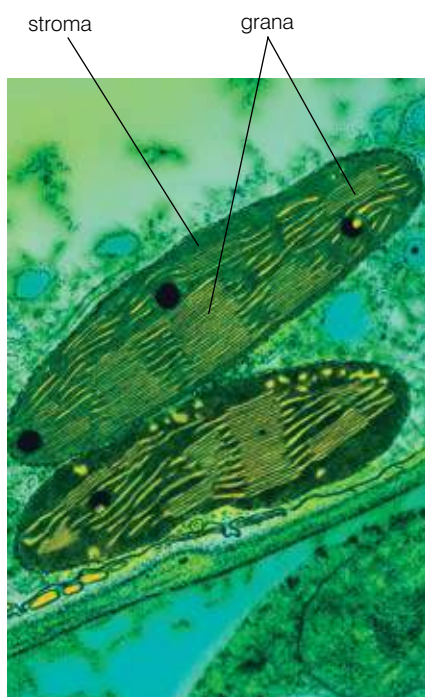
**Chloroplast**

Figure 4.41 is an electron-micrograph showing the structure of a chloroplast. Chloroplasts are surrounded by two membranes, like mitochondria, but, unlike mitochondria, the inner membrane is not folded. There are two main regions in chloroplasts that are linked to the stages of photosynthesis:

- membranous regions called **grana** (each of which is a stack of **thylakoids**) where the light-dependent reactions occur, and
- a fluid stroma – where the light-independent reactions occur.

**How have biologists been able to study the different organelles?**

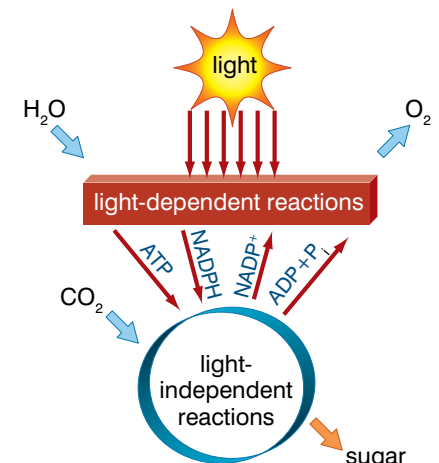
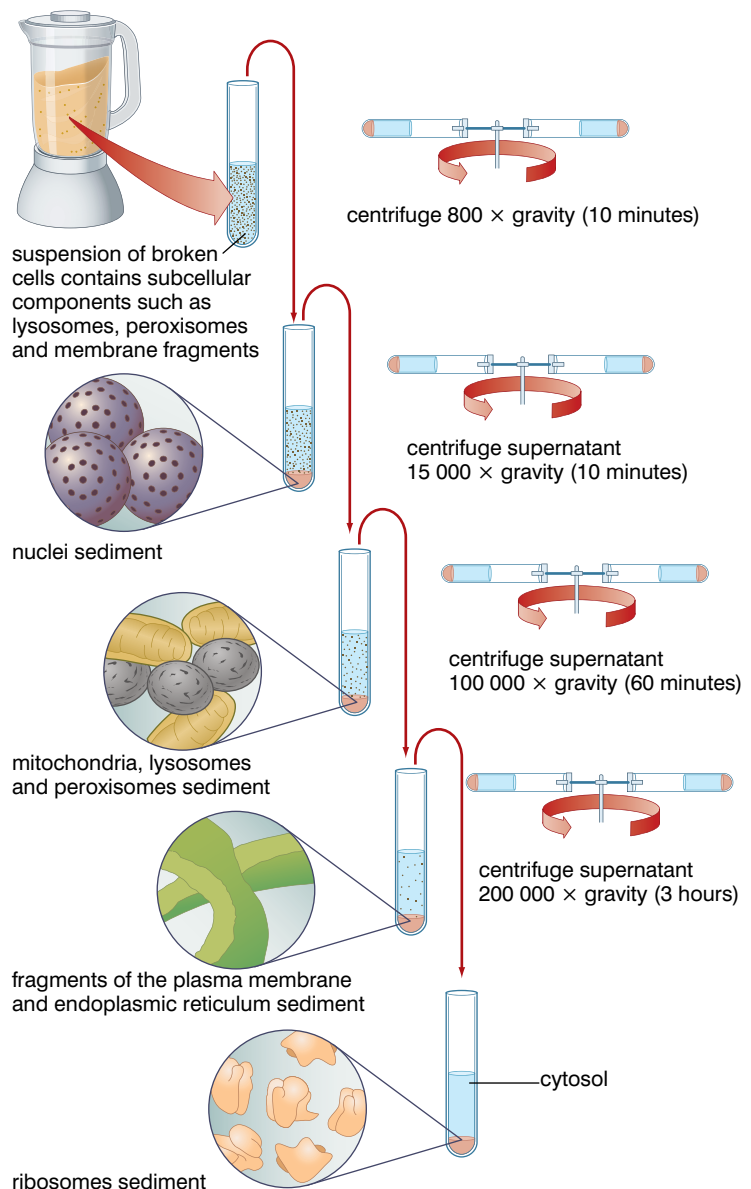
This has been possible because of a technique called cell fractionation. The technique is based on the fact that the masses of organelles vary and depend on their size. When a mixture of organelles is spun in a centrifuge, the various types settle out at different speeds of spinning. The large nucleus requires a relatively low centrifuge speed to make it settle out; the much smaller ribosomes require a much higher speed. The technique is carried out as follows:



**Figure 4.41** An electron-micrograph of a chloroplast



- The cell sample is stored in a suspension that is:
  - buffered – the neutral pH prevents damage to the structure of proteins, including enzymes
  - isotonic (of equal water potential) – this prevents osmotic water gain or loss by the organelles; gaining too much water could rupture the organelles
  - cool – this reduces the overall activity of enzymes released later in the procedure
- The cells are homogenised in a blender and filtered to remove debris.
- The homogenised sample is placed in an ultracentrifuge and spun at low speed. The nuclei settle out, forming a pellet.
- The supernatant (the suspension containing the remaining organelles) is spun at a higher speed – chloroplasts settle out (if plant tissue is used).
- The supernatant is spun at a higher speed still – mitochondria settle out.
- The process is repeated at ever higher speeds until all the organelles have been separated.
- The process is shown in figure 4.43.



**Figure 4.42** Light-dependent and light-independent reactions of photosynthesis

**Figure 4.43** Cell fractionation

## Review questions

Choose the correct answer from A to D.

- To convert millimetres to micrometres:
  - multiply by 1000
  - divide by 100
  - divide by 1000
  - multiply by 100
- The functions of the rough endoplasmic reticulum and the Golgi body are related because:
  - proteins synthesised by the rough endoplasmic reticulum are modified by the Golgi body
  - proteins synthesised by the Golgi body are modified by the rough endoplasmic reticulum
  - lipids synthesised by the Golgi body are modified by the rough endoplasmic reticulum
  - lipids synthesised by the rough endoplasmic reticulum are modified by the Golgi body
- In cell fractionation, the purpose of keeping the tissue sample in an isotonic solution in a refrigerator prior to homogenisation is:
  - to prevent osmotic damage to the cells and to reduce the metabolic activity of the cells
  - to prevent osmotic damage to the cells and to increase the metabolic activity of the cells
  - to prevent osmotic damage to the organelles and to reduce the metabolic activity of the cells
  - to prevent osmotic damage to the organelles and to increase the metabolic activity of the cells
- Which of the following is not part of the structure of mitochondria?
  - a double membrane surrounding the organelle
  - a fluid matrix inside the organelle
  - stacks of membranes known as thylakoids
  - folds of membranes known as cristae
- The plasma membrane provides:
  - structural support for the cell and regulates which substances enter and leave
  - structural support for the cell but does not regulate which substances enter and leave

- C no structural support for the cell and does not regulate which substances enter and leave
  - D no structural support for the cell but regulates which substances enter and leave
6. The principle behind separating cell organelles by ultracentrifugation is that:
- A the various organelles have different masses
  - B the various organelles have different volumes
  - C the various organelles have different shapes
  - D the various organelles have different widths
7. Which of the following does not use energy in the form of ATP?
- A active transport
  - B endocytosis
  - C facilitated diffusion
  - D phagocytosis
8. Which of the following statements concerning mitochondria and chloroplasts is correct?
- A Only mitochondria are surrounded by two membranes.
  - B The inner membrane of chloroplasts is folded into cristae.
  - C Both organelles have a fluid interior.
  - D Mitochondria contain stacks of membranes called thylakoids.
9. If red blood cells are immersed in a hypotonic solution, they will:
- A take in water by osmosis, swell and become turgid
  - B lose water by osmosis and shrink
  - C lose water by osmosis and burst
  - D take in water by osmosis, swell and burst
10. In the fluid mosaic model of membrane structure, intrinsic proteins can be:
- A glycoproteins
  - B ion channel proteins
  - C carrier proteins
  - D all of the above

## Summary

In this unit you have learnt that:

- A cell is the smallest unit of life capable of independent existence.
- The cell theory proposed by Schleiden and Schwann stated:
  - the cell is the unit of structure, physiology and organisation in living things
  - the cell retains a dual existence as:
    - a distinct entity, and
    - a 'building block' in the formation of organisms.
- Virchow added another important idea which was that all cells come from pre-existing cells.
- Modern cell theory also includes the ideas that:
  - cells contain hereditary information which is passed from cell to cell during cell division
  - all cells have basically the same chemical composition
  - all energy flow (the metabolism and biochemistry of life) occurs within cells
- Dimensions of cells are measured in units derived from the metre, including:
  - millimetre, mm = 0.001 m
  - micrometre,  $\mu\text{m}$  = 0.000,001 m (0.001 mm)
  - nanometre, nm = 0.000,000,001 m (0.001  $\mu\text{m}$ )
- We can measure the size of cells using an eyepiece graticule calibrated by a stage micrometer.
- As cells increase in size, the surface-area-to-volume ratio decreases; this affects their ability to obtain the resources they need to carry out their metabolism.
- There are two main types of cells: prokaryotic cells and eukaryotic cells; the table shows the differences between them.

Feature	Prokaryotic cells	Eukaryotic cells
Size	1–10 $\mu\text{m}$	10–100 $\mu\text{m}$
Nucleus	No membrane-bound nucleus	Nucleus surrounded by nuclear envelope
DNA	<ul style="list-style-type: none"> <li>• In a continuous loop</li> <li>• Not associated with protein to form chromosomes</li> </ul>	<ul style="list-style-type: none"> <li>• Linear DNA</li> <li>• Associated with histone proteins in chromosomes</li> </ul>
Mitochondria	Absent	Present
Chloroplasts	Absent	Present
Ribosomes	Smaller than in eukaryotic cells (70S)	Larger than in prokaryotic cells (80S)
Cell wall	<ul style="list-style-type: none"> <li>• Always present</li> <li>• Not made from cellulose</li> </ul>	<ul style="list-style-type: none"> <li>• Present in some</li> <li>• Cellulose in plant cells</li> </ul>

- Animal cells contain a nucleus, mitochondria, lysosomes, ribosomes, ER (rough and smooth) as well as Golgi apparatus, all enclosed within a plasma membrane.
- Plant cells contain all the same organelles but also contain chloroplasts, a cellulose cell wall and a permanent vacuole.
- The organelles of cells have specific functions:
  - the nucleus contains DNA which controls the metabolism of the cell
  - mitochondria carry out aerobic respiration to release energy from organic molecules and store it in the ATP molecule
  - ribosomes synthesise proteins from amino acids
  - lysosomes contain hydrolytic enzymes that digest worn-out or damaged organelles as well as engulfed bacteria
  - the Golgi body modifies proteins and distributes them to the appropriate part of the cell
  - chloroplasts in plant cells carry out the reactions of photosynthesis
  - the plant cell wall supports and protects the contents of the cell; it is freely permeable to all molecules
  - the vacuole in plant cells contains a solution of mineral ions and sugars; it is important in maintaining the turgor of the cell
- The current model of the structure of the plasma membrane is called the fluid mosaic model; most biologists now prefer this model to Davson and Danielli's 'sandwich' model.
- The fluid mosaic model suggests that:
  - the plasma membrane is based on a phospholipid bilayer
  - cholesterol molecules in this bilayer reduce the fluidity of the membrane
  - the plasma membrane has protein molecules 'studded' in the bilayer
  - some proteins are intrinsic (trans-membrane), whilst others are extrinsic (only span part of the membrane)
  - proteins can be:
    - channel proteins with ion pores
    - carrier proteins for facilitated diffusion or for active transport
    - glycoproteins for cell signalling and cell recognition
- Molecules pass through the plasma membrane in several ways, summarised in the table overleaf.

### Activity 4.11

Work in groups. This is a revision exercise. Each group should draw or make a model of one cell organelle and research as much as possible about that organelle. Each group then presents the details of their organelle and its role in the cell to the rest of the class.

Process	Influence of concentration	Requirement for ATP?	Type of particles moved	Transport proteins needed?
Simple diffusion	Occurs from high to low	No	Lipid-soluble, small, non-polar	No
Facilitated diffusion	Occurs from high to low	No	Ions and medium-sized particles	No
Osmosis	Occurs from high to low (water potential)	No	Water molecules	No
Active transport	Occurs from low to high	Yes	Ions and medium-sized, non-lipid-soluble particles	Yes
Endocytosis	Can occur either way	Yes	Very large particles	Yes
Exocytosis	Can occur either way	Yes	Very large particles	Yes

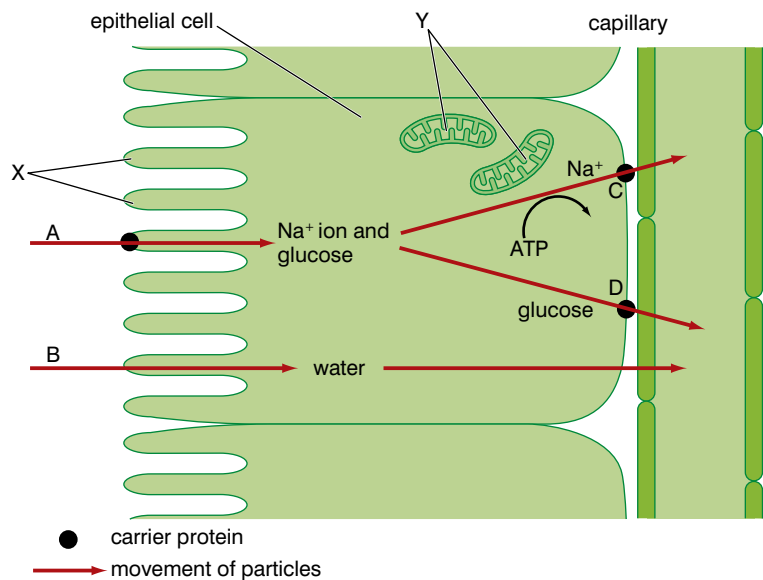
- Cell fractionation separates the components of a cell by centrifugation, heavier organelles being isolated at lower centrifuge speeds.

### End of unit questions

- Schleiden and Schwann were the first biologists to put forward a tenable cell theory.
    - State two ideas of this theory that we still accept today.
    - State one idea of this theory that we reject today.
    - Name the biologist who modified Schleiden and Schwann's theory to make it acceptable to us.
  - State the cell theory as we understand it today.
- Describe the role of each of the following in the development of a cell theory:
  - Robert Hooke
  - Anton van Leeuwenhoek
  - Rene Dutrochet
- Copy and complete the table.

Feature	Prokaryotic cells	Eukaryotic cells
Size	1–10 $\mu\text{m}$	
Nucleus		
DNA	• in a continuous loop	• •
Mitochondria		
Ribosomes	70S ribosomes	

4. The diagram represents the uptake of glucose, sodium ions and water by an epithelial cell in a kidney tubule.
- Suggest how the structures labelled X help to maintain a high rate of absorption from the lumen of the kidney tubule.
  - Explain how the presence of the organelles labelled Y is essential to the absorption of glucose.
  - Name, with a reason, the transport process occurring at A, B, C and D.
5. The table below shows the percentage masses of protein, lipid and carbohydrate in four different plasma membranes.



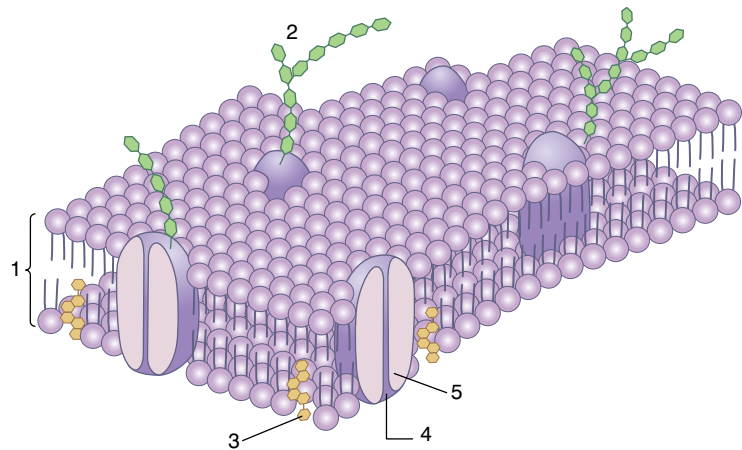
Membrane	Percentage mass		
	Protein	Lipid	Carbohydrate
A	18	79	3
B	51	49	0
C	52	44	4
D	76	24	0

- Calculate the mean ratio of protein to lipid for the four membranes.
  - Describe two functions of proteins in plasma membranes.
  - Describe one function of carbohydrates in plasma membranes.
  - Suggest why plasma membrane D has a much higher protein content than plasma membrane A.
6. a) Copy and complete the table showing the functions of cell organelles.

Organelle	Function
	Contains DNA, regulates cell metabolism
Ribosome	
	Site of aerobic respiration, produces most of the ATP in a cell
	Modifies structure of protein molecules
Lysosome	
Chloroplast	
	Controls entry and exit of substances from cell
	Gives cell support and rigidity

- b) Describe the main stages in the process of cell fractionation. Explain why each stage is necessary.

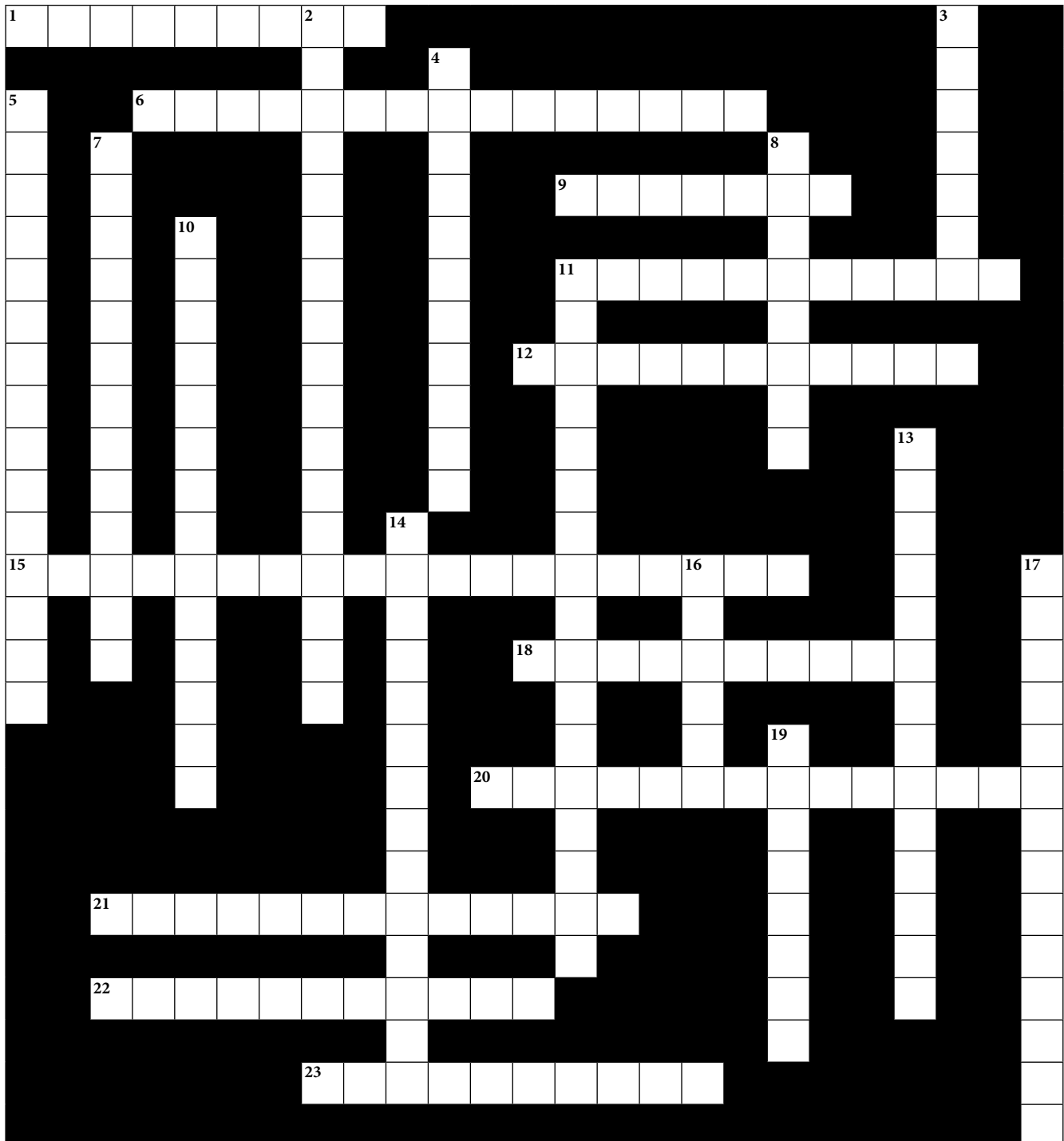
7. The diagram shows the structure of a plasma membrane.



- Name the structures numbered 1, 2, 3 and 4.
  - Describe the function of the structure labelled 5.
  - This model of the structure of a membrane is called the fluid mosaic model. Explain why.
8. Write a short essay to describe the history of the development of modern cell theory. In your essay, try to explain why events happened as and when they did. You will be given credit for logical presentation and breadth of coverage as well as for scientific accuracy.



Copy the crossword puzzle below into your exercise book (or your teacher may give you a photocopy) and solve the numbered clues to complete it.



### Across

1. The organelle in which proteins are modified (5, 4)
6. Process that moves particles across the plasma membrane against the concentration gradient (6, 9)
9. The process by which water moves across the plasma membrane (7)
11. The site of photosynthesis in a plant cell (11)

12. The model of plasma membrane structure proposed by Sanger and Nicholson in 1972 (5, 6)
15. The Germans who proposed the first cell theory (9, 3, 7)
18. Unit in which the size of cells and cell organelles is measured (10)
20. The membrane at the surface of the cell (6, 8)
21. The site of aerobic respiration in a cell (13)
22. This Englishman drew dead cork cells that he saw through his microscope (6, 5)
23. Cells with chromosomes and membrane-bound organelles (10)

**Down**

2. These biologists suggested that the plasma membrane was a 'sandwich' of protein and lipid (6, 3, 8)
3. The organelle that controls all the cell's activities (7)
4. Cells with no true nucleus (11)
5. Process by which small, lipid-soluble and non-polar particles cross the plasma membrane (6, 9)
7. The German who stated that 'a cell can only arise from another cell like it' (6, 7)
8. The site of protein synthesis in a cell (8)
10. A measure of the free energy of water molecules in a solution (5, 9)
11. The procedure that allows biologists to separate different cellular organelles (4, 13)
13. A protein in the plasma membrane that moves medium-sized particles across the membrane (7, 7)
14. Anton ... the Dutchman who saw 'animalcules' and bacteria through an early microscope (3, 11)
16. This famous organism has only one cell (6)
17. A protein in the plasma membrane that allows ions to cross (7, 7)
19. Organelles like the nucleus, mitochondrion and chloroplast are said to be ... bound (8)

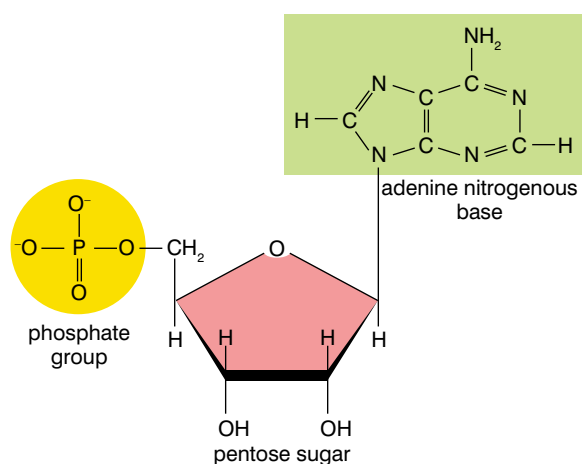
Contents	
Section	Learning competencies
5.1 Respiration (page 152)	<ul style="list-style-type: none"> <li>• Describe the structure of ATP and its role in cellular metabolism.</li> <li>• Explain how ATP is adapted to its role as an energy transfer molecule within a cell.</li> <li>• Describe how ATP is produced in a cell.</li> <li>• Locate where the different processes of cellular respiration occur in the cell.</li> <li>• Explain the role of electron donors and acceptors.</li> <li>• Describe in detail each stage of aerobic respiration.</li> <li>• Draw and label the structure of a mitochondrion.</li> <li>• Explain the processes of alcoholic fermentation and lactate production.</li> <li>• Appreciate the importance of lactate production during running and other sports.</li> <li>• Summarise the metabolism of proteins, polysaccharides and lipids.</li> </ul>
5.2 How do plants harness light energy in photosynthesis? (page 170)	<ul style="list-style-type: none"> <li>• Draw, label and describe a chloroplast.</li> <li>• Locate where light-dependent and -independent processes occur in the chloroplast.</li> <li>• Name the products of the light-dependent and -independent processes.</li> <li>• Explain how the structure of a photosystem is related to its function.</li> <li>• Explain what is meant by a photosynthetic unit.</li> <li>• Describe how glucose is synthesised in the light-independent reactions of photosynthesis.</li> <li>• Describe the factors that affect the rate of photosynthesis and explain why they affect the rate.</li> <li>• Separate photosynthetic pigments by paper chromatography.</li> <li>• Explain photorespiration and how it is related to higher temperatures.</li> <li>• Distinguish between C3 and C4 plants and give at least three examples of each.</li> <li>• Appreciate the importance of C4 plants in Ethiopia.</li> <li>• Describe the CAM photosynthetic pathway and explain why this brings added benefits to plants living in desert conditions.</li> </ul>

## 5.1 Respiration

By the end of this section you should be able to:

- Describe the structure of ATP and its role in cellular metabolism.
- Explain how ATP is adapted to its role as an energy transfer molecule within a cell.
- Describe how ATP is produced in a cell.
- Locate where the different processes of cellular respiration occur in the cell.
- Explain the role of electron donors and acceptors.
- Describe in detail each stage of aerobic respiration.
- Draw and label the structure of a mitochondrion.
- Explain the processes of alcoholic fermentation and lactate production.
- Appreciate the importance of lactate production during running and other sports.
- Summarise the metabolism of proteins, polysaccharides and lipids.

### What is the ATP molecule like?



**Figure 5.1** A nucleotide containing the nitrogenous base adenine

The full name for ATP is **Adenosine Tri-Phosphate** – but you will not need to use this name, all biologists always refer to it as ATP. So why bother telling you? Well, it helps to understand about the structure of the molecule.

In unit 2, we learned that nucleic acids are built from nucleotides, like the one shown in figure 5.1.

All nucleotides contain:

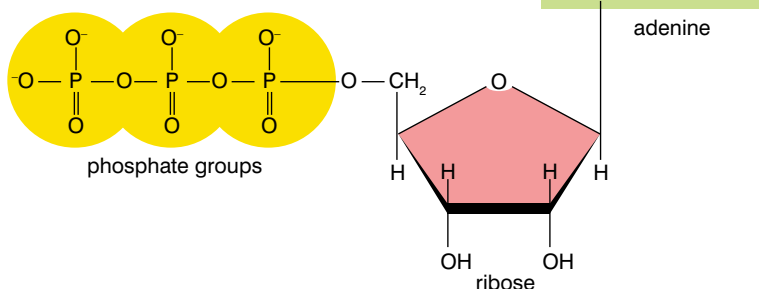
- a nitrogenous base (this one contains adenine)
- a pentose sugar
- a phosphate group

The ATP molecule is based on this nucleotide. ATP is sometimes described as a **phosphorylated nucleotide**. If you look at figure 5.2, you can perhaps work out why. When you ‘phosphorylate’ a molecule, you add one or more phosphate groups to it. ATP is essentially the adenine nucleotide with two extra phosphate groups added on – making three in all. Adding the extra phosphates requires energy, particularly when the third phosphate is added. As a result, energy is stored in the ATP molecule and when the bonds that hold this third phosphate in place are broken, the energy is released again. When the third phosphate is removed from ATP,

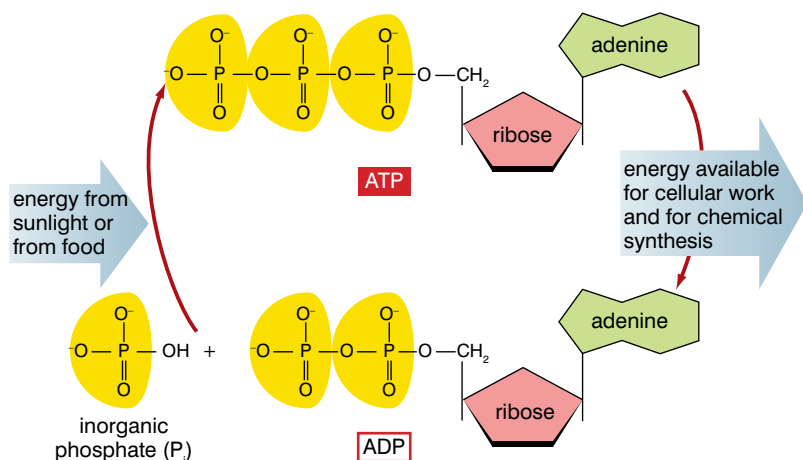
we are still left with a phosphorylated nucleotide, but this one only has two nucleotides. It is **Adenosine Di-Phosphate** – or **ADP**.

The phosphate group that is split off is usually written as  $P_i$  as a kind of shorthand to save writing out the full formula.

The inter-conversion of ADP and ATP is shown in figure 5.3. Notice that the diagram says that the energy to form ATP can come from ‘sunlight or from food’. This is because ATP is formed in both photosynthesis and in cellular respiration.



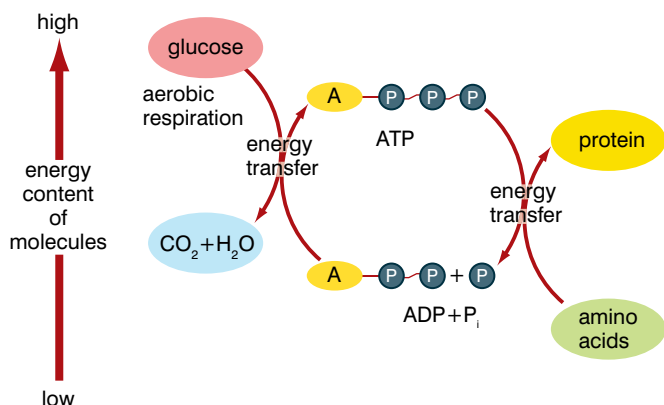
**Figure 5.2** The structure of the ATP molecule



**Figure 5.3** The inter-conversion of ADP and ATP

### How is ATP adapted to its role as an energy transfer molecule in cells?

First, we must explain what we mean by an energy transfer molecule. Sunlight energy cannot be used directly by plants (and certainly not by other organisms) to ‘drive’ the synthesis of proteins – or any other molecules. The same applies to the energy held in a glucose molecule. These two energy sources must be used to produce ATP, which is used to transfer the energy to the relevant cellular process. We say that it is coupled to these processes.



**Figure 5.4** Coupled reactions transfer energy in cells

### KEY WORDS

**phosphorylated nucleotide**  
the adding of one or more phosphate groups to a molecule

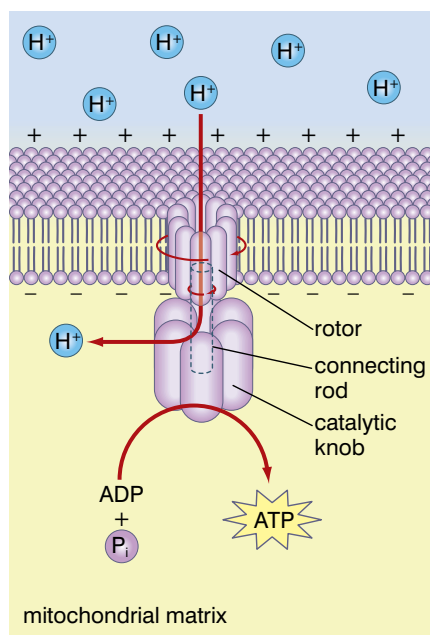
**adenosine di-phosphate**  
removing the third phosphate from ATP leaves a phosphorylated nucleotide with two nucleotides

### DID YOU KNOW?

All living cells respire all the time to produce the ATP they need. There are no exceptions.

**KEY WORD**

**ATP synthase** enzyme involved in the formation of ATP



**Figure 5.5** The structure of ATP synthase

**DID YOU KNOW?**

**About the ADP/ATP inter-conversion**

More than one eminent biologist has said ‘the whole biological world turns on the coupling and uncoupling of the third phosphate of ATP’. This is because this process is virtually the only way in which energy can be harnessed and then released to drive metabolic processes in cells.

ATP is adapted to this role because it:

- releases energy in relatively small amounts that are closely matched to the amounts of energy required in many biological processes occurring inside cells
- releases energy in a single-step hydrolysis reaction, so the energy can be released quickly
- is able to move around the cell easily, but cannot escape from the cell

The following processes are examples of processes that require energy from ATP:

- the synthesis of macromolecules – such as proteins
- active transport across a plasma membrane (see unit 4 for details)
- muscle contraction
- conduction of nerve impulses
- the initial reactions of respiration (the later reactions release energy from glucose to form more ATP)

**How is ATP produced in a cell?**

Almost all the ATP produced in cells is formed in the same way. It obviously involves ADP and P<sub>i</sub> joining to form ATP and this requires an input of energy. What we need to look at is just how it is made to happen.

The formation of ATP involves an enzyme called **ATP synthase**. Figure 5.5 shows the structure of the ATP synthase molecule. The ATP synthase in this diagram is in one of the membranes of a mitochondrion, but it could be in a membrane in a chloroplast.

To understand how it works, you should think of it as a kind of molecular ‘water wheel’. When the rotor is made to spin by hydrogen ions passing through it, the energy of the spinning is used to activate sites in the catalytic knob that convert ADP and P<sub>i</sub> to ATP.

In both photosynthesis and aerobic respiration, many of the reactions generate the hydrogen ions that will pass through the ATP synthase to produce ATP.

**How is ATP produced in respiration?**

There are two main pathways by which respiration can produce ATP:

- the aerobic pathway (aerobic respiration) – this requires the presence of oxygen, and
- the anaerobic pathway (anaerobic respiration and fermentation) – this can take place in the absence of oxygen.

## How is ATP produced in aerobic respiration?

A small amount of ATP is produced in a way that does not involve the ATP synthase molecule; this method is called **substrate level phosphorylation**. In this process, another molecule such as phosphoenol pyruvate (the *substrate*) is able to transfer a phosphate group directly to ADP. There is no ATP synthase involved and no  $P_i$ . The process is still catalysed by an enzyme, it is just not ATP synthase.

Figure 5.6 shows how substrate level phosphorylation works. As already mentioned, this process only produces a relatively small amount of the ATP produced in aerobic respiration – in fact it produces about 10% of the total ATP produced in aerobic respiration.

As about 90% of the ATP produced in aerobic respiration is produced by ATP synthase, many of the reactions of this process are geared to producing the hydrogen ions that will spin the rotor of the ATP synthase molecule.

Many different organic molecules can be respired – they are called **respiratory substrates**. However, glucose is the most commonly respired substrate and so we will begin by looking at how this molecule is respired.

### How are hydrogen ions transferred from glucose to ATP synthase?

Two molecules are important in this transfer process:

- Nicotinamide Adenine Dinucleotide (NAD)
- Flavine Adenine Dinucleotide (FAD)

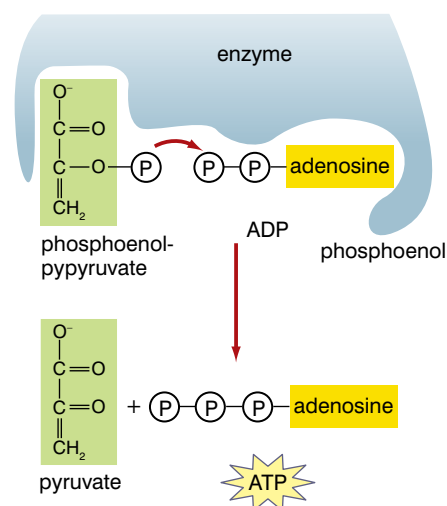
Both are coenzymes and are capable of accepting hydrogen ions. When this happens, we say that the molecules have been **reduced**. We write the reduced forms of the molecules as NADH and FADH or NAD(reduced) and FAD(reduced).

These molecules can release their hydrogen ions and become **oxidised** again. The hydrogen ions can then be used to turn the rotor of ATP synthase.

### What are the stages of aerobic respiration of glucose?

There are four stages in the aerobic respiration of glucose. These are:

- glycolysis
- the link reaction
- Krebs cycle
- electron transport and chemiosmosis



**Figure 5.6** Substrate level phosphorylation

#### KEY WORDS

**substrate level phosphorylation** when another molecule (*substrate*) is able to transfer a phosphate group directly to ADP

**respiratory substrates** organic molecules that can be respired

**reduce** decrease the oxidation state of a substance

**oxidise** increase the oxidation state of a substance

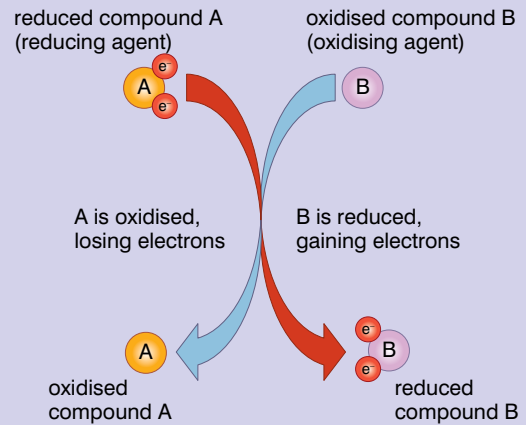
#### Activity 5.1

Make a simple model of ATP which you can use to demonstrate how it is converted to ADP and back again by the removal or addition of a phosphate group.

**DID YOU KNOW?**

**Oxidation and reduction**

Reduction is the opposite of oxidation, in which particles accept oxygen, lose hydrogen or lose electrons. In reduction, a particle loses oxygen, gains hydrogen or gains electrons. When a particle of compound A is oxidised by (say) losing electrons, the electrons have to go somewhere. A particle of compound B accepts the electrons and is reduced. The two processes always happen together and the reactions in which they are involved are called redox (reduction and oxidation) reactions. Figure 5.7 shows this.



*Figure 5.7 A redox reaction*

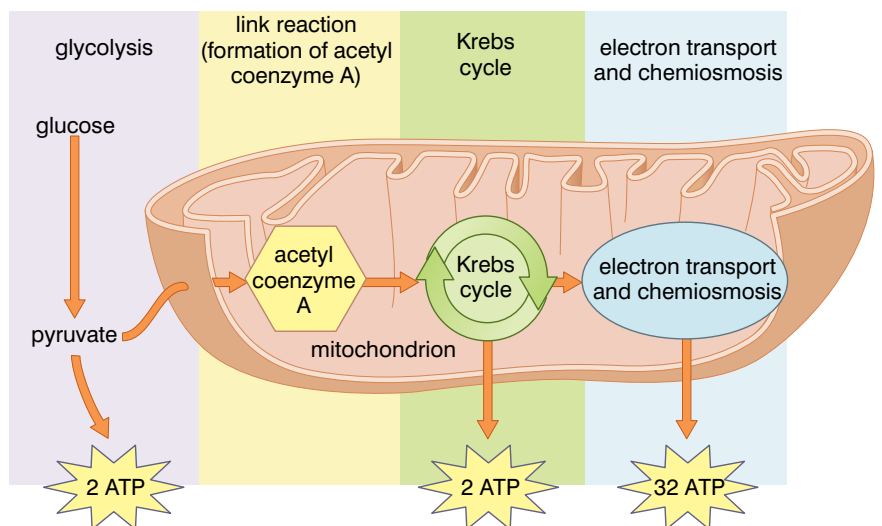
**Activity 5.2**

Draw and label a simple diagram of a mitochondrion which shows where the various parts of cellular respiration takes place and demonstrates the importance of the mitochondrial membranes.

The first stage, glycolysis, takes place in the cytoplasm. It does not take place inside the mitochondria because:

- the glucose molecule cannot diffuse through the mitochondrial membranes (it is a medium-sized molecule and is not lipid soluble), and
- there are no carrier proteins to transport the glucose molecule across the membranes.

Glycolysis (literally 'glucose splitting') results in glucose being converted into a smaller molecule containing only three carbon atoms – pyruvate. Pyruvate can enter the mitochondria and so all the other stages take place inside the mitochondrion. Figure 5.8 shows where the stages of aerobic respiration take place.



*Figure 5.8 The stages of aerobic respiration*

In the link reaction, pyruvate is then converted into a two-carbon compound that enters into a cycle of reactions – the Krebs cycle (named after Sir Hans Krebs who discovered the reactions involved). Both these stages take place in the fluid **matrix** of a mitochondrion.



In all three stages (glycolysis, the link reaction and Krebs cycle), hydrogen atoms are transferred to NAD to produce reduced NAD. The Krebs cycle also produces reduced FAD. These molecules later release their hydrogen atoms as protons (hydrogen ions) and electrons in the final stage of aerobic respiration. The electrons pass along a series of molecules called an **electron transport chain**. The protons are used in the chemiosmotic synthesis of ATP as they spin the rotor of the ATP synthase enzyme located in the inner membrane of the mitochondrion. Eventually, the protons (hydrogen ions) and electrons will combine with oxygen to form water.

Without the oxygen, this cannot happen as there is nothing at the end of the electron transport chain to accept the electrons. The electron transport chain grinds to a halt and so does the production of ATP by ATP synthase. Because it is oxygen-dependent, this method of production of ATP is called **oxidative phosphorylation**.

The link reaction, Krebs cycle and the reactions of the electron transport chain all depend on the presence of oxygen. None of these occurs in anaerobic respiration. Glycolysis can take place in the absence of oxygen and is the only energy-releasing process in anaerobic respiration.

### What happens in glycolysis?

The reactions of glycolysis take place in the cytoplasm. The following reactions take place in glycolysis:

- two molecules of ATP are used to 'phosphorylate' each molecule of glucose. This makes the glucose more reactive
- in the phosphorylation process, it is converted to another six-carbon sugar (fructose 1,6-bisphosphate)
- the fructose 1,6-bisphosphate is split into two molecules of the three-carbon sugar glyceraldehyde-3 phosphate (GP)
- each molecule of GP is then converted into pyruvate, with the production of two molecules of ATP (by substrate level phosphorylation) and one molecule of reduced NAD

The main reactions of glycolysis are shown in figure 5.9. Note:

- the figures in brackets give the number of carbon atoms in that molecule, so (6C) means six carbon atoms per molecule
- two molecules of pyruvate are produced from one molecule of glucose

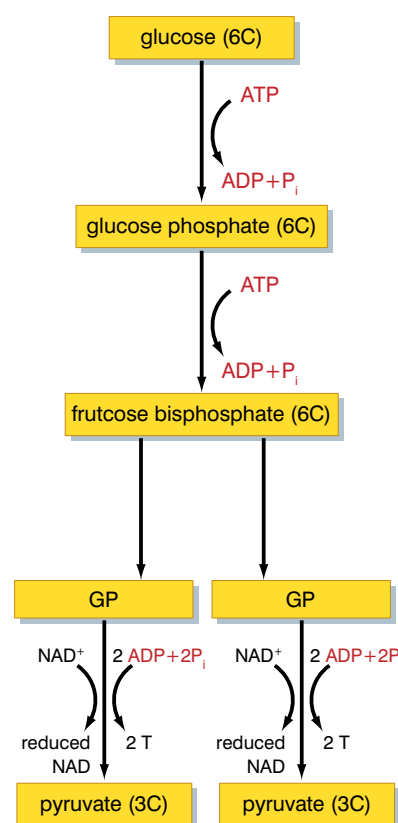
At the end of glycolysis, there is a net gain of two ATP molecules per molecule of glucose (two molecules are used initially and then four are produced). Two molecules of reduced NAD are also produced (per molecule of glucose). The molecules of pyruvate pass into the mitochondria through carrier molecules in the mitochondrial membrane.

### KEY WORDS

**matrix fluid in the mitochondrion in which the reactions of the Krebs cycle take place**

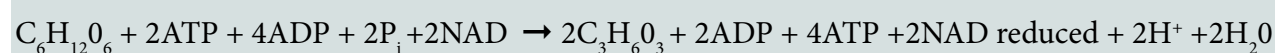
**electron transport chain** a series of molecules along which electrons travel

**oxidative phosphorylation** oxygen-dependent production of ATP



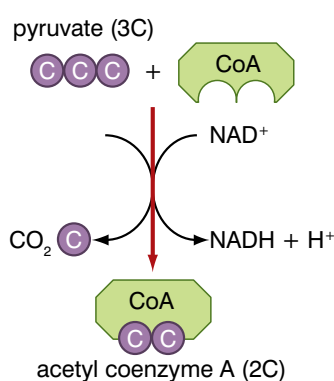
**Figure 5.9** The main stages of glycolysis

A summary of the overall reaction of glycolysis:



**Two ideas to keep in mind**

1. The idea of net gain of ATP is like the profit a business makes. It invests money in materials, advertising and staff. It sells its product and the extra money is profit – net gain. Glycolysis ‘invests’ two molecules of ATP to make the glucose reactive, then, later, produces four molecules of ATP – a net gain of two molecules of ATP.
2. There are two molecules of pyruvate made from each molecule of glucose. So all the gains of ATP and reduced NAD and reduced FAD that accrue from each pyruvate must be doubled to give the gain from each molecule of glucose.



**Figure 5.10** The link reaction

Both of these stages of respiration take place in the fluid matrix of the mitochondrion.

In the link reaction, a molecule of pyruvate reacts with a molecule of **coenzyme A** (CoA) to form a molecule of **acetyl coenzyme A** (acetyl CoA). In the reaction:

- hydrogen is lost and reduced NAD is formed; removing hydrogen from a molecule is **dehydrogenation**
- a carbon atom is lost to form carbon dioxide; removing carbon from a molecule is **decarboxylation**.

The acetyl coenzyme A then reacts with a C<sub>4</sub> molecule (a molecule containing four carbon atoms) called oxaloacetate. In the reaction, acetyl CoA breaks down into:

- a two-carbon ‘acetyl’ group, which reacts with the C<sub>4</sub> compound oxaloacetate to form a C<sub>6</sub> compound, and
- the original coenzyme A molecule, which is reused in further reactions with other molecules of pyruvate.

This is the first reaction of the Krebs cycle.

**What happens in the Krebs cycle?**

- the two-carbon group from acetyl coenzyme A reacts with the four-carbon compound **oxaloacetate** to form a six-carbon compound called **citrate**
- citrate then loses a carbon atom (is decarboxylated) to form a five-carbon compound and CO<sub>2</sub> is produced
- the five-carbon compound is then further decarboxylated to form a four-carbon compound and CO<sub>2</sub> is again produced; a molecule of ATP is also produced by substrate level phosphorylation
- the four-carbon compound undergoes several molecular transformations to regenerate the original four-carbon compound (oxaloacetate) and the cycle is complete and can begin again with oxaloacetate reacting with another molecule of acetyl CoA

**KEY WORDS**

**coenzyme A** *coenzyme derived from pantothenic acid needed for respiration*

**acetyl coenzyme A** *produced by the reaction of coenzyme A with a molecule of pyruvate*

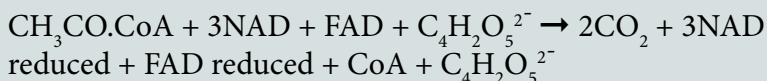
**dehydrogenation** *removing hydrogen from a molecule*

**decarboxylation** *removing carbon from a molecule*

- in several reactions in the cycle, reduced NAD is produced and, in just one reaction, reduced FAD is produced

The reactions of the Krebs cycle are summarised in figure 5.12.

A summary of the overall reaction of the Krebs cycle:



### What happens in the electron transport chain and chemiosmosis?

The electron transport chain and chemiosmosis together make up the process of oxidative phosphorylation.

Whereas the reactions of the link reaction and Krebs cycle take place in the fluid matrix of the mitochondrion, the reactions of the electron transport chain and chemiosmosis take place on the inner mitochondrial membrane. Figure 5.13 shows an electron-micrograph of a mitochondrion.

On the cristae, the following events take place:

- the hydrogen atoms carried by reduced NAD and reduced FAD are released and split into protons (hydrogen ions) and electrons
- the electrons pass along a series of electron carriers that form the transport chain; they lose energy as they pass from one carrier to the next
- three of the electron carriers are proton pumps that move protons from the matrix of the mitochondrion to the inter-membrane space
- as the electrons are transferred through these three proton pumps, the energy they lose powers the pumps which move the protons into the inter-membrane space
- electrons from reduced NAD make this happen at all three pumps

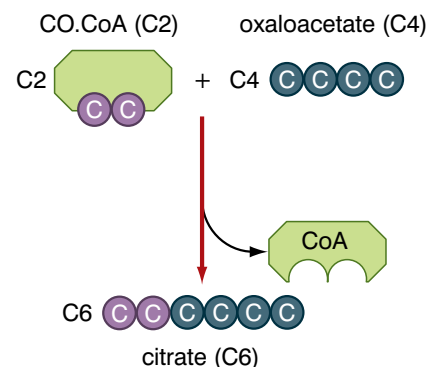
The molecules that act as electron carriers in the electron transport chain are:

- reduced NAD dehydrogenase (also a proton pump)
- ubiquinone (also a proton pump), and
- a number of carriers called cytochromes (these are proteins that contain iron); two of them form a complex that acts as the third proton pump.

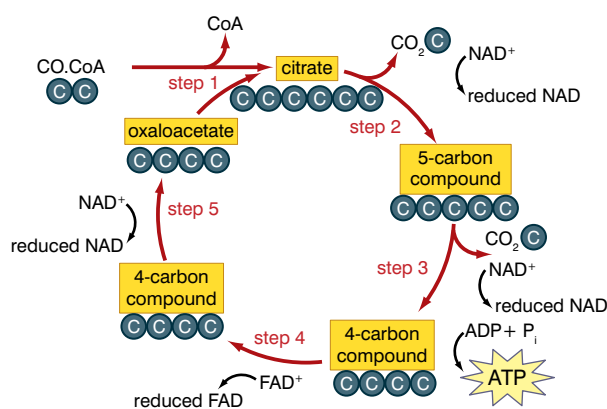
#### KEY WORDS

**oxaloacetate** an ester of oxaloacetic acid

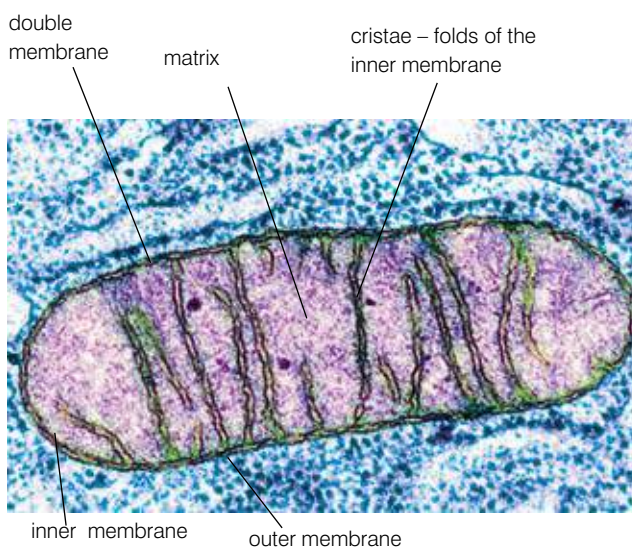
**citrate** an ester of citric acid



**Figure 5.11** The first reaction of the Krebs cycle

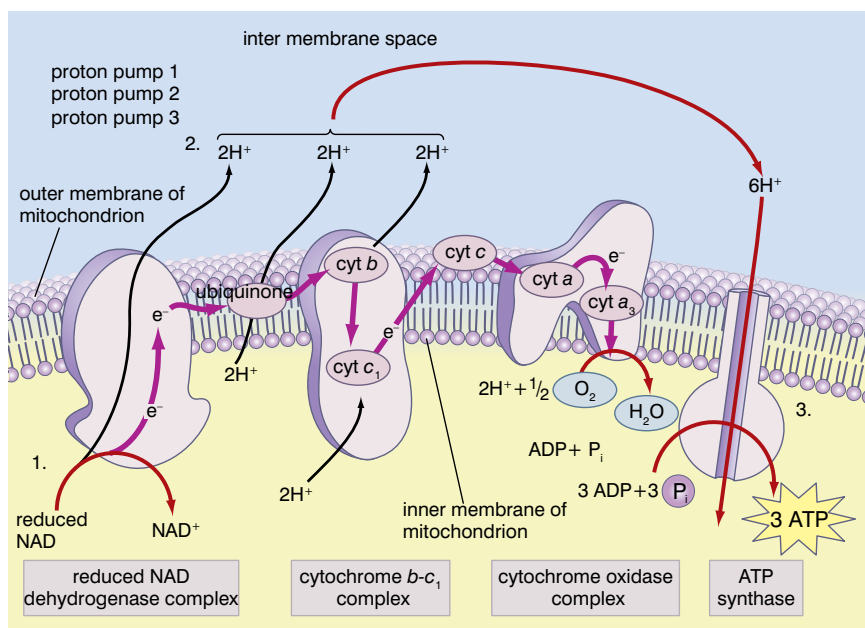


**Figure 5.12** The main stages of the Krebs cycle



**Figure 5.13** An electron-micrograph of a mitochondrion

The arrangement of these molecules is shown in figure 5.14.



**Figure 5.14** The carrier molecules in the electron transport chain on the inner membrane of a mitochondrion

At the end of the electron transport chain, the electrons combine with protons and with oxygen to form molecules of water. Because of this, oxygen is known as the **terminal electron acceptor**.

Whereas reduced NAD is dehydrogenated by the NAD dehydrogenase complex, reduced FAD is dehydrogenated by ubiquinone. So electrons from reduced FAD only operate two of the three proton pumps.

Because of the action of the proton pumps, protons accumulate in the inter-membrane space creating a higher concentration there than in the matrix (on the other side of the membrane). This proton gradient results in protons diffusing through the ATP synthase molecule (down the concentration gradient) making the synthase rotor 'spin' and produce ATP from ADP and P<sub>i</sub>. The diffusion of hydrogen ions through the ATP synthase is chemiosmosis.

The oxidation of one molecule of reduced NAD results in six protons passing through ATP synthase and so leads to the synthesis of three molecules of ATP.

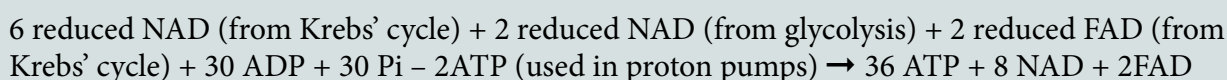
The oxidation of one molecule of reduced FAD results in four protons passing through ATP synthase and so leads to the synthesis of just two molecules of ATP.

By adding up the number of molecules of ATP produced, the model of aerobic respiration we have discussed predicts that there will be a net yield of 38 molecules of ATP per molecule of glucose.

### KEY WORD

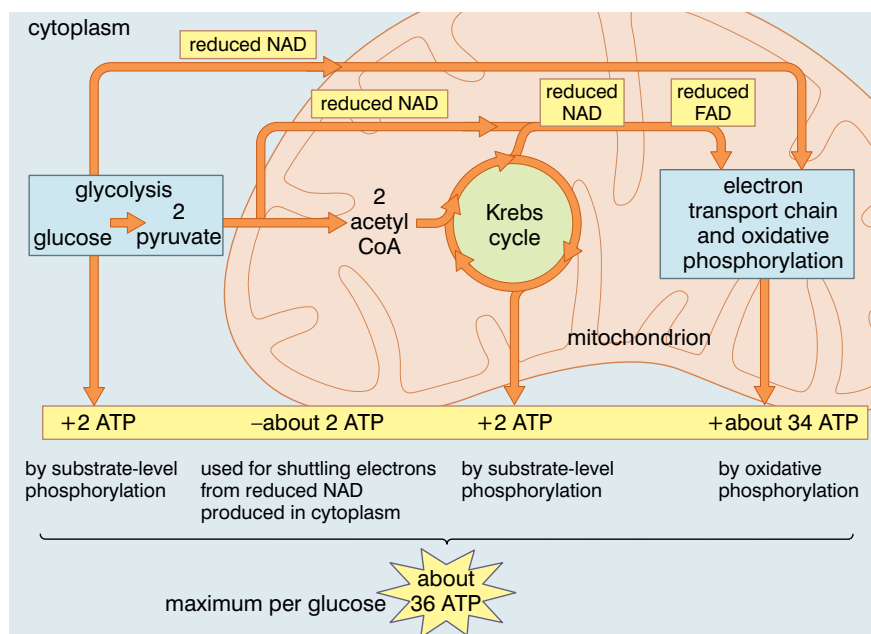
**terminal electron acceptor**  
the final molecule at the end of the electron transport chain to accept an electron

A summary of the overall reaction of the electron transport system:



In practice, this is not achieved because some energy (the equivalent of just over two molecules of ATP) is used to drive the proton pumps. The actual yield is about 36 molecules of ATP per molecule of glucose.

Figure 5.15 summarises the production of ATP in aerobic respiration.

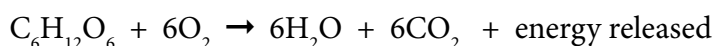


### Activity 5.3

Make a large annotated wall chart showing glycolysis and Krebs cycle and how they are linked together. Make sure you show the different compounds and where ATP is formed. This should be as accurate as possible so it can form the basis of your revision of this complex topic.

**Figure 5.15** The production of ATP during the aerobic respiration of glucose

The summary equation for aerobic respiration is:



### Respirometers

Respirometers come in several different forms, but they all work on the principle that oxygen is used in aerobic respiration and carbon dioxide is produced.

The overall summary equation for the aerobic respiration of glucose is:



This equation predicts that the volume of oxygen used ( $6\text{O}_2$ ) is equal to the volume of carbon dioxide produced ( $6\text{CO}_2$ ). This is the basis of how respirometers work.

Figure 5.16 overleaf shows a basic respirometer. For every molecule of oxygen the organism uses, a molecule of carbon dioxide will be produced, but, the carbon dioxide will be absorbed by the potassium hydroxide (KOH). So, over time, there will be a reduction in volume inside the respirometer.

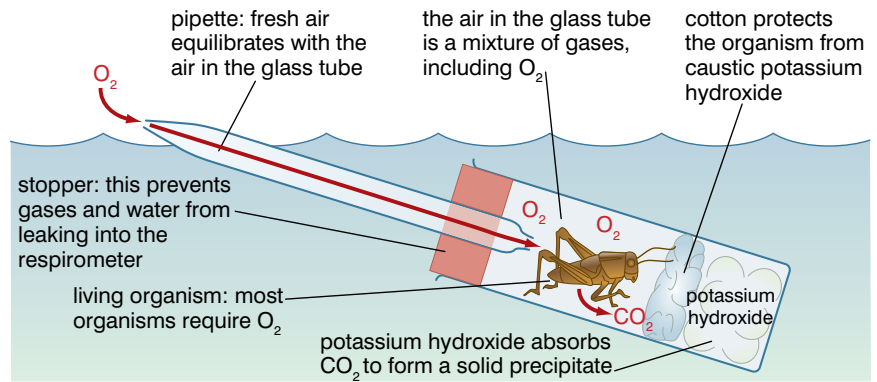


Figure 5.16 A basic respirometer

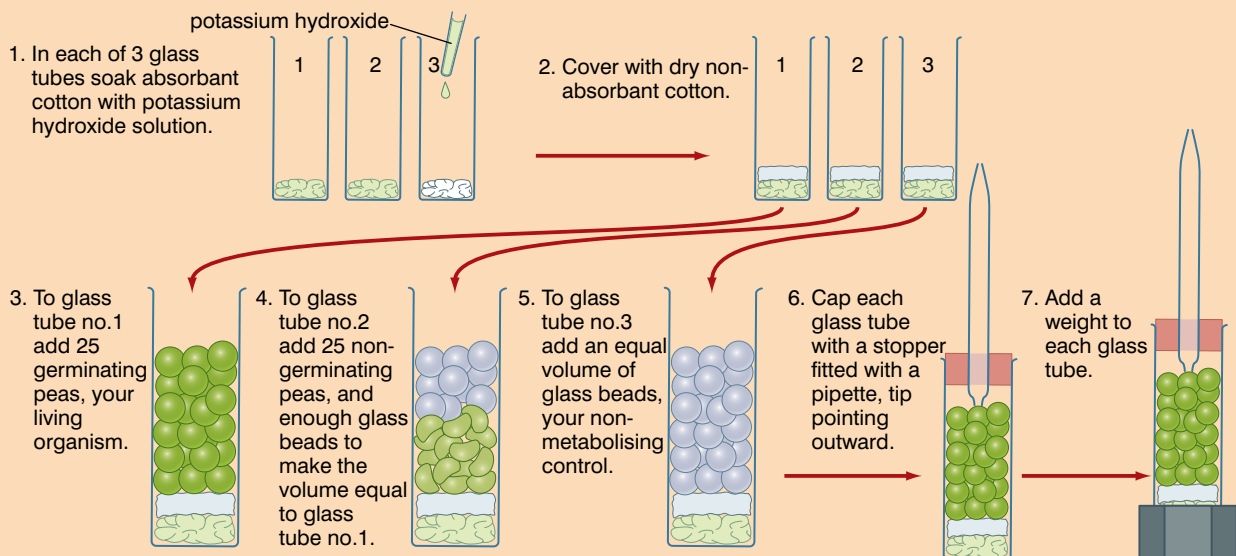
Figure 5.16 shows the respirometer placed under water. As the volume inside the respirometer decreases, water will enter the pipette. The volume of water entering is equal to the volume of oxygen being used up. We can use this to measure the rate of respiration by measuring how much oxygen is used in a set period of time (say 10 minutes) then working out a rate per minute.

Activity 5.4: Measuring the rate of respiration of pea seeds

You will need

- 3 respirometers, set up as in figure 5.17
- 3 water baths

Figure 5.17 How to assemble a respirometer



Method

1. Place the three respirometers in a water bath at 20 °C with the tips of the pipettes out of the water, resting on a sling of tape. Leave them for five minutes to equilibrate.
2. Lower the tips of each pipette into the water and immediately:
  - take a reading from each
  - start a timer
3. Take a reading from each respirometer every two minutes for 20 minutes.
4. Repeat the investigation at 30 °C and at 40 °C.

The volume of oxygen used is the same as the volume of water that has entered the pipette.

There are several aspects of this experiment you should consider:

- Why did we use tubes containing non-germinating peas and glass beads as well as the tube with the germinating peas?
- Why does the water move into the pipette during the investigation?
- What was the purpose of leaving the tubes for five minutes before starting each investigation?
- How could you investigate temperatures lower than 20 °C?

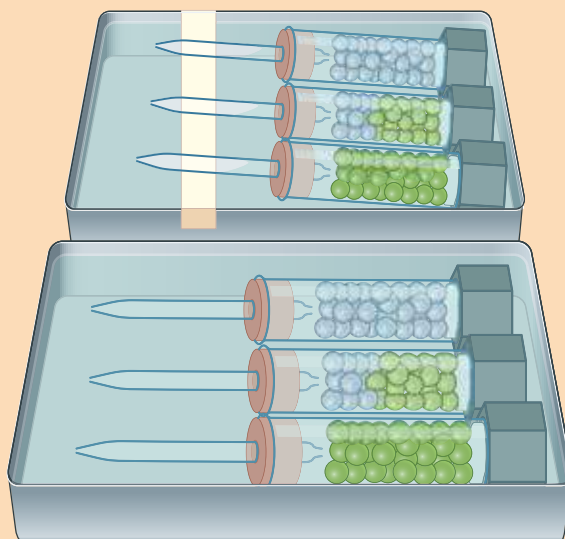
A different design of respirometer removes the need to set up three at the same time. This is shown in Figure 5.19.

In this design, the tap on tube A is left open for five minutes at the start of the investigation and the levels of the coloured oil in the U-tube are equalised with the syringe.

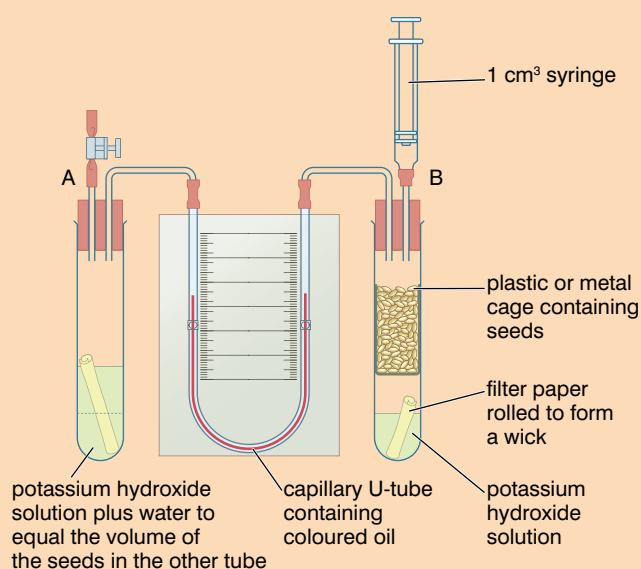
When the investigation starts, the tap is closed and the coloured oil moves towards the organisms (tube B). The distance it moves per minute is a measure of the rate of respiration.

Once one investigation is complete, the tap can be reopened and the levels reset using the syringe ready for a repeat or another investigation at a different temperature.

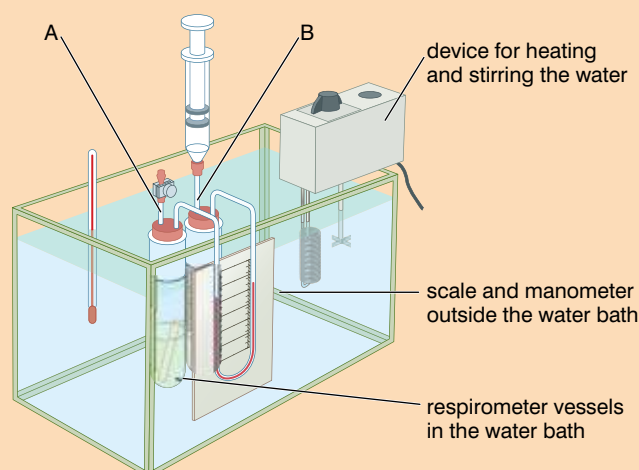
In this design of respirometer, tube A acts as a control tube and so another set of apparatus with glass beads or non-germinating seeds is not necessary. Figure 5.20 shows how this respirometer can be used to investigate the rate of respiration at different temperatures.



**Figure 5.18** Carrying out the experiment



**Figure 5.19** A more sophisticated respirometer



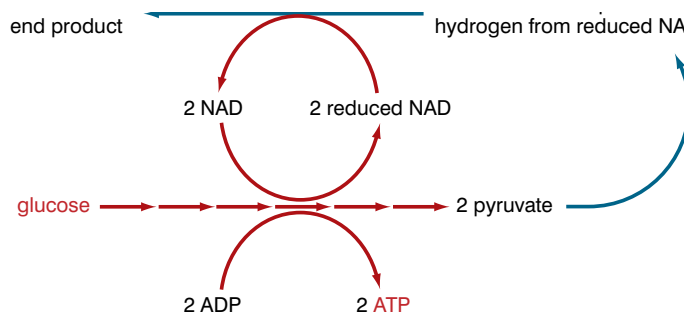
**Figure 5.20** Using the respirometer in a water bath

### What happens in the anaerobic pathway?

If there is no oxygen present, the final reaction of oxidative phosphorylation, where electrons and protons react with oxygen to form water, cannot take place. As a result, the electron transport chain comes to a halt. No protons are pumped and the action of ATP synthase also stops.

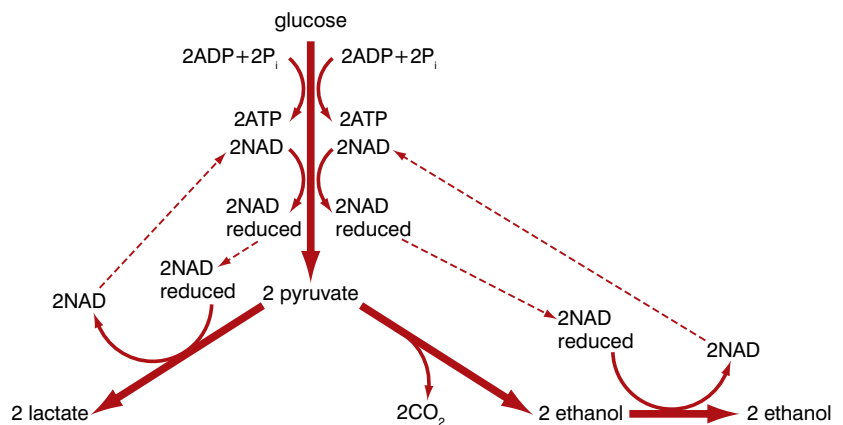
There is a further ‘knock-on’ effect. If the electron transport chain does not function, NAD is not regenerated from reduced NAD and FAD is not regenerated from reduced FAD. Very quickly, the Krebs cycle and the link reaction come to a halt as both NAD and FAD are required in their oxidised forms for the Krebs cycle to function. NAD is also required in the link reaction and so this comes to a halt also.

However, glycolysis *can* continue even though it also requires NAD. This is because the reduced NAD formed during glycolysis can be regenerated under anaerobic conditions by converting the pyruvate into another product in a reduction reaction. Reduced NAD supplies the hydrogen for this reduction and becomes oxidised itself. It is therefore regenerated and can be used again in glycolysis.



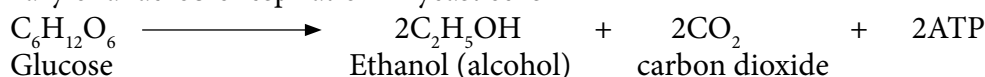
**Figure 5.21** How NAD is regenerated in fermentation

Different organisms produce different fermentation end products. Animal cells produce lactate (lactic acid) when they ferment glucose. Yeast cells produce ethanol (ethyl alcohol). But both only produce two molecules of ATP per molecule of glucose.

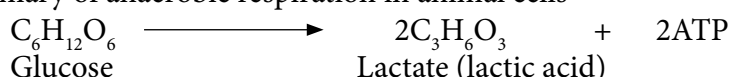


**Figure 5.22** The fermentation processes in animal cells and yeast

A summary of anaerobic respiration in yeast cells



A summary of anaerobic respiration in animal cells





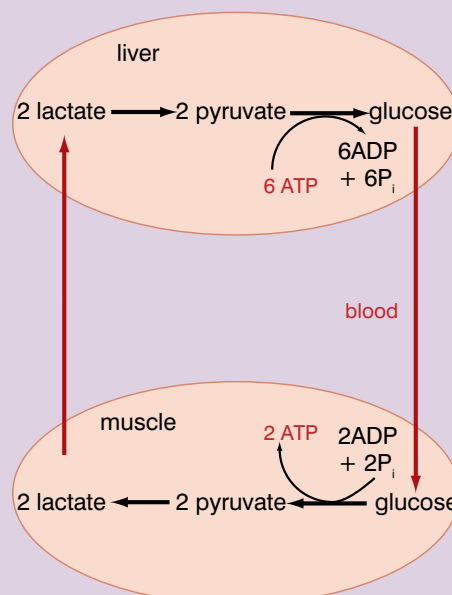
**KEY IDEA**

**Lactate formation during exercise**

During exercise, the energy demand of muscle cells increases greatly. More glucose is respired to meet the demand. However, sometimes, aerobic respiration is insufficient to meet this energy demand. Fermentation of glucose supplies the extra energy. But it also forms lactate and as this accumulates, it leads to muscle fatigue. Also, fermentation only yields 2 molecules of ATP per molecule of glucose whereas aerobic respiration yields 38. However, fermentation is a much faster process and can produce a lot of ATP quickly, over a short period of time. The ATP used in sprints and short-distance runs is nearly all generated anaerobically.

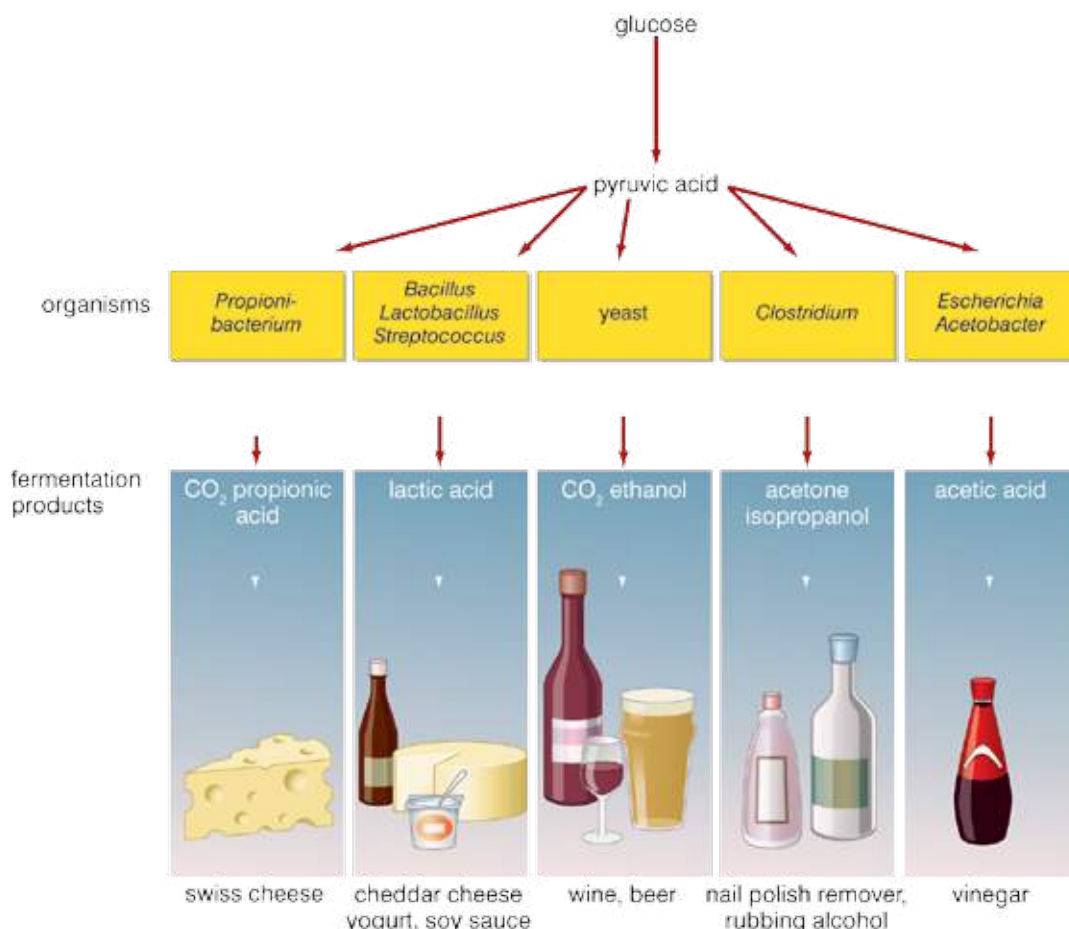
But, due to muscle fatigue, this cannot be sustained. Longer races must be run slower to allow aerobic respiration to produce the ATP at its slower rate.

Lactate, once formed, can be used to regenerate glucose or be metabolised as an energy source by the liver. Figure 5.23 shows how the Cori cycle makes this happen.



**Figure 5.23** The Cori cycle

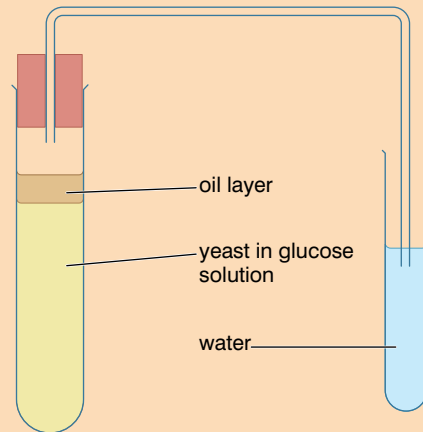
Other organisms produce other fermentation products, many of which are made use of in different industries. Figure 5.24 shows some of these.



**Figure 5.24** Some uses of fermentation in industry

**Activity 5.5: Investigating the rate of fermentation in yeast**

There are many different ways of carrying out this investigation, ranging from those using only basic equipment to sophisticated electronically monitored fermenters. Figure 5.25 shows just about the simplest way of investigating this. The test tube containing the yeast and glucose can be held in a water bath at the desired temperature and the number of bubbles collected per minute recorded. However, rate of bubbling is not the most accurate way of measuring rate of respiration. Are you sure that all the bubbles are the same volume? The method is improved if the test tube of water is replaced by a gas syringe.



**Figure 5.25** A simple way of investigating the rate of fermentation in yeast

Using this basic equipment, can you devise experiments to investigate:

- the effect of temperature on the rate of fermentation
- the effect of different substrates (different sugars) on the rate of fermentation
- the effect of substrate concentration on the rate of fermentation

In your plans, you should make clear:

- the independent variable
- the dependent variable
- other variables that you intend to control as well as:
  - why you need to control them, and
  - how you intend to control them.

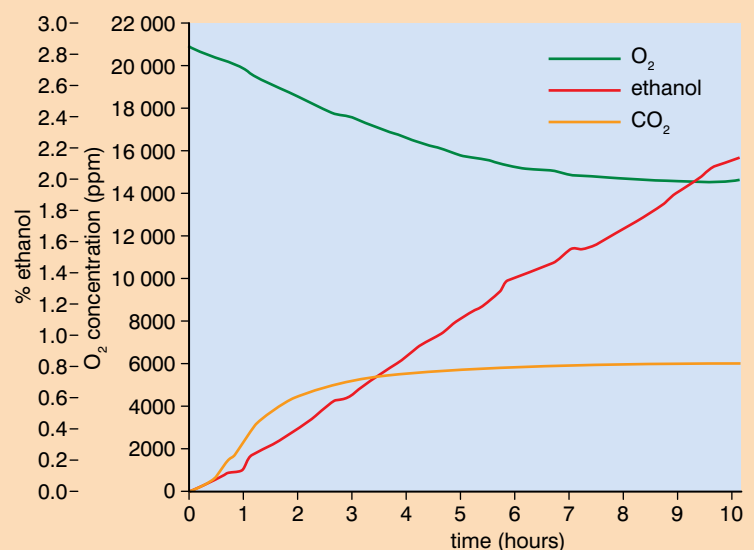


**Figure 5.26** A fermenter that monitors changes electronically

More sophisticated fermenters (such as that shown in figure 5.26) control all the conditions inside the fermenter and monitor the changes in the concentration of oxygen, carbon dioxide and ethanol. Other sensors could also monitor the concentration of the sugar being fermented.

Figure 5.27 shows the output from one such fermenter.

Can you explain the changes in the concentrations of the various substances as fermentation proceeds?



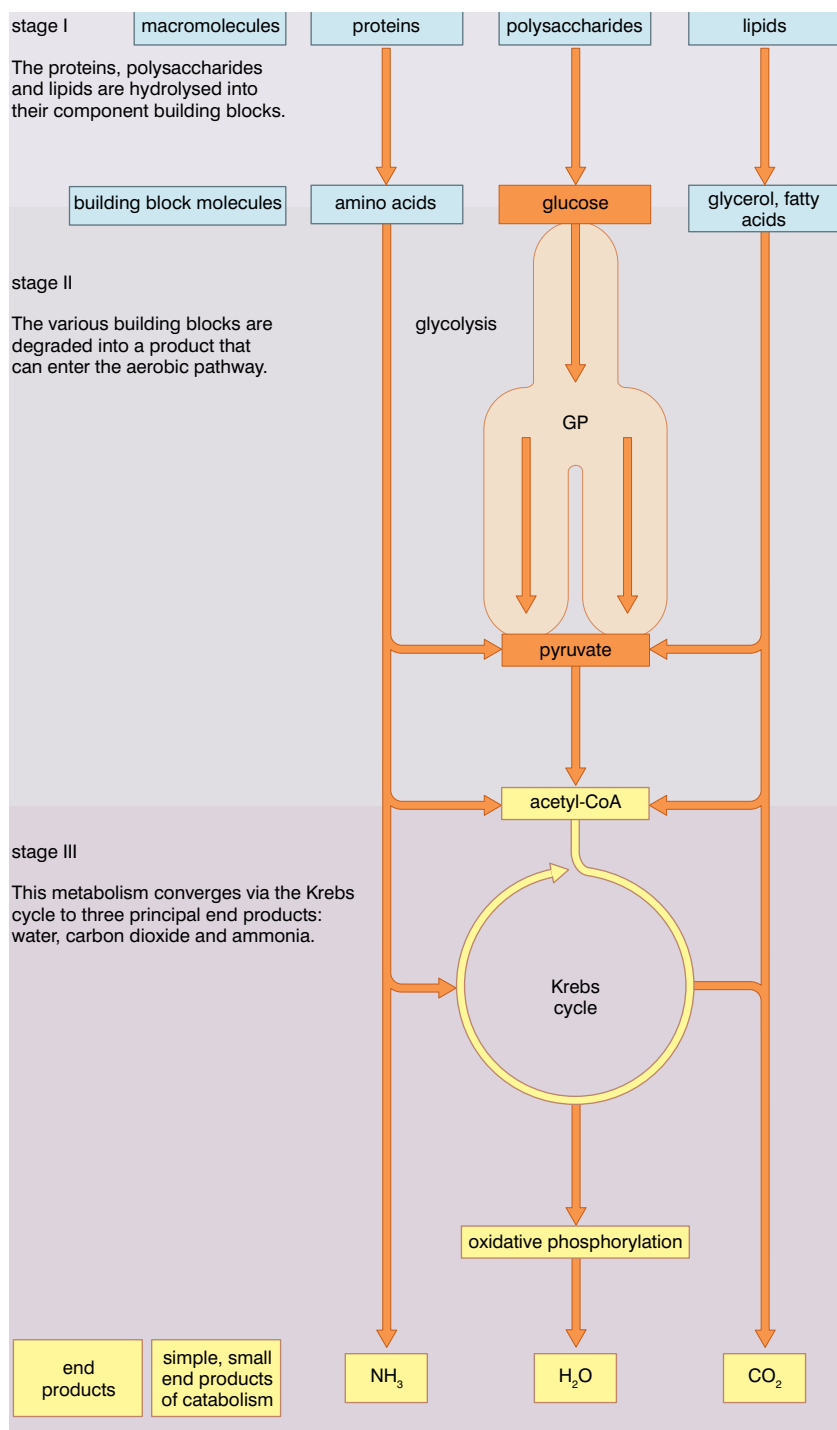
**Figure 5.27** Output from a fermenter

### What substances can be used as energy sources?

We have so far concentrated on the respiration and fermentation of glucose. But lipids and proteins can also be used as respiratory substrates. Figure 5.28 shows how lipids and proteins are converted into substances that can enter the aerobic respiration pathway at some point. The metabolism of proteins, lipids and carbohydrates ‘converges’ on the Krebs cycle.

### Activity 5.6

Plan a simple demonstration of anaerobic respiration in the muscles. Several students work together. You are going to investigate how quickly anaerobic respiration sets in by repeating a simple action until the muscles begin to ache. This action could be stepping on and off a step or box, and repeatedly lifting a book from the surface of the desk to the shoulder. All start the action together and time how long it takes for the muscle aching which indicates a build up of lactic acid to develop. Explain exactly what is happening in the muscles and discuss what individuals can do to change their physiology and maintain aerobic respiration in their muscles for as long as possible.



**Figure 5.28** The metabolic pathways by which carbohydrates, lipids and proteins are respired

**Activity 5.7**

The Krebs cycle was worked out by Hans Krebs. He was awarded a Nobel Prize for his work. Find out as much as you can about Krebs and how he came to discover the chemistry of aerobic respiration in the cell. You can look in encyclopaedias, in other text books and online, e.g.

[http://www.nobel-winners.com/Medicine/hans\\_adolf\\_krebs.html](http://www.nobel-winners.com/Medicine/hans_adolf_krebs.html)

[http://nobelprize.org/nobel\\_prizes/medicine/laureates/1953/krebs-bio.html](http://nobelprize.org/nobel_prizes/medicine/laureates/1953/krebs-bio.html)

[http://en.wikipedia.org/wiki/Hans\\_Adolf\\_Krebs](http://en.wikipedia.org/wiki/Hans_Adolf_Krebs)

**Review questions**

Choose the correct answer from A to D.

- The ATP molecule is sometimes described as:
  - a phosphorylated nitrogenous base
  - a phosphorylated nucleotide
  - a glycosated nucleotide
  - a glycosated nitrogenous base
- ATP is formed from:
  - AMP and  $P_i$
  - ADP and AMP
  - ADP and  $P_i$
  - AMP and A
- Examples of processes requiring ATP include:
  - simple diffusion and active transport
  - active transport and facilitated diffusion
  - conduction of nerve impulses and osmosis
  - active transport and protein synthesis
- The ATP synthase molecule produces ATP when:
  - electrons turn the rotor to activate sites in the catalytic knob
  - hydrogen ions spin the catalytic knob
  - electrons spin the catalytic knob
  - hydrogen ions turn the rotor to activate sites in the catalytic knob
- ATP is an ideal energy transfer molecule in cells because it:
  - releases energy in small amounts
  - releases energy quickly
  - can move freely in, but not escape from, the cell
  - all of the above
- Which of the following does not take place during the Krebs cycle?
  - oxidative phosphorylation
  - substrate-level phosphorylation
  - electron transport
  - the link reaction
- In fermentation:
  - oxidative phosphorylation does not take place
  - substrate-level phosphorylation does take place
  - NAD is reduced in glycolysis
  - all of the above

8. Which of the following statements about mitochondria is NOT true?
- A the carrier molecules of the electron transfer chain are found on the inner mitochondrial membranes
  - B the reactions of the Krebs cycle take place inside the mitochondria
  - C all of the ATP needed by the cell is made in the mitochondria
  - D much of the ATP needed by the cell is made in the mitochondria
9. In the electron transport chain, electrons are passed:
- A from the lumen of the mitochondrion to the inter-membrane space
  - B from the inter-membrane space to the lumen of the mitochondrion
  - C through ATP synthase
  - D along a series of electron carriers
10. Oxidative phosphorylation includes:
- A the electron transport chain and chemiosmosis
  - B the electron transport chain and the Krebs cycle
  - C the Krebs cycle and chemiosmosis
  - D none of these
11. In the Krebs cycle:
- A some ATP is made by oxidative phosphorylation
  - B the four-carbon compound oxaloacetate is regenerated
  - C ATP is used
  - D the six-carbon compound citrate is split into two three-carbon compounds
12. When compared with aerobic respiration, fermentation of glucose by yeast:
- A yields less ATP per molecule of glucose
  - B produces lactate
  - C produces more  $\text{CO}_2$
  - D none of the above
13. Which of the following statements about aerobic respiration is correct?
- A Glycolysis takes place in the matrix of the mitochondrion.
  - B Carrier molecules of the electron transport chain exist on the outer membrane of the mitochondrion.
  - C A high concentration of hydrogen ions builds up in the matrix of the mitochondrion.
  - D The Krebs cycle takes place in the matrix of the mitochondrion.

**Activity 5.8**

Work as a whole class with your teacher. Before you begin to study photosynthesis, brainstorm everything you know about photosynthesis from your studies in the lower grades. Your teacher will put all your ideas together into a big spider diagram and keep it until the end of this topic. Then you can look back and see how much you have learned.

14. In a respirometer...
  - A the amount of oxygen used by the organism is replaced with an equal amount of carbon dioxide
  - B the carbon dioxide given off is absorbed by potassium hydroxide
  - C the breathing rate of an organism is measured
  - D we measure the uptake of oxygen by an organism
15. Which of the following occur in both aerobic respiration and fermentation in mammals:
  - A substrate-level phosphorylation
  - B chemiosmosis
  - C link reaction
  - D decarboxylation

**5.2 How do plants harness light energy in photosynthesis?**

By the end of this section you should be able to:

- Draw, label and describe a chloroplast.
- Locate where light-dependent and -independent processes occur in the chloroplast.
- Name the products of the light-dependent and -independent processes.
- Explain how the structure of a photosystem is related to its function.
- Explain what is meant by a photosynthetic unit.
- Describe how glucose is synthesised in the light-independent reactions of photosynthesis.
- Describe the factors that affect the rate of photosynthesis and explain why they affect the rate.
- Separate photosynthetic pigments by paper chromatography.
- Explain photorespiration and how it is related to higher temperatures.
- Distinguish between C<sub>3</sub> and C<sub>4</sub> plants and give at least three examples of each.
- Appreciate the importance of C<sub>4</sub> plants in Ethiopia.
- Describe the CAM photosynthetic pathway and explain why this brings added benefits to plants living in desert conditions.

## Photosynthesis

In photosynthesis, light energy is used in a series of reactions that lead to the synthesis of a range of organic molecules. The energy that entered the system as light is now held in the organic molecules produced. It is now chemical energy. When energy is changed from one form to another, we say it has been **transduced**. This takes place in a series of reactions called the **light-dependent reactions**. Light energy is absorbed by special **photosensitive pigments** such as **chlorophyll** in the chloroplasts. The light-dependent reactions take place in the membranes of the **thylakoids** in the chloroplasts. The liquid stroma is the site of the light-independent reactions, in which carbohydrates are synthesised. Chemical reactions like these take place most effectively in solution, rather than if some were fixed in membranes.

### How is the structure of a chloroplast suited to its function?

The chlorophyll and other photosensitive pigment molecules are arranged in special **photosystems** that are linked to electron transport chains (ETCs). The molecules of the photosystems and the electron transport chains are fixed in the membranes of the thylakoids. This makes the process much more efficient than if they were just floating around in a solution.

There are two different photosystems, each sensitive to light of a different wavelength and linked to a different electron transport chain. These are called **photosystem I** and **photosystem II**.

### KEY WORDS

**transduced** *conversion of energy from one form to another*

**light-dependent reactions** *reactions of photosynthesis dependent on light*

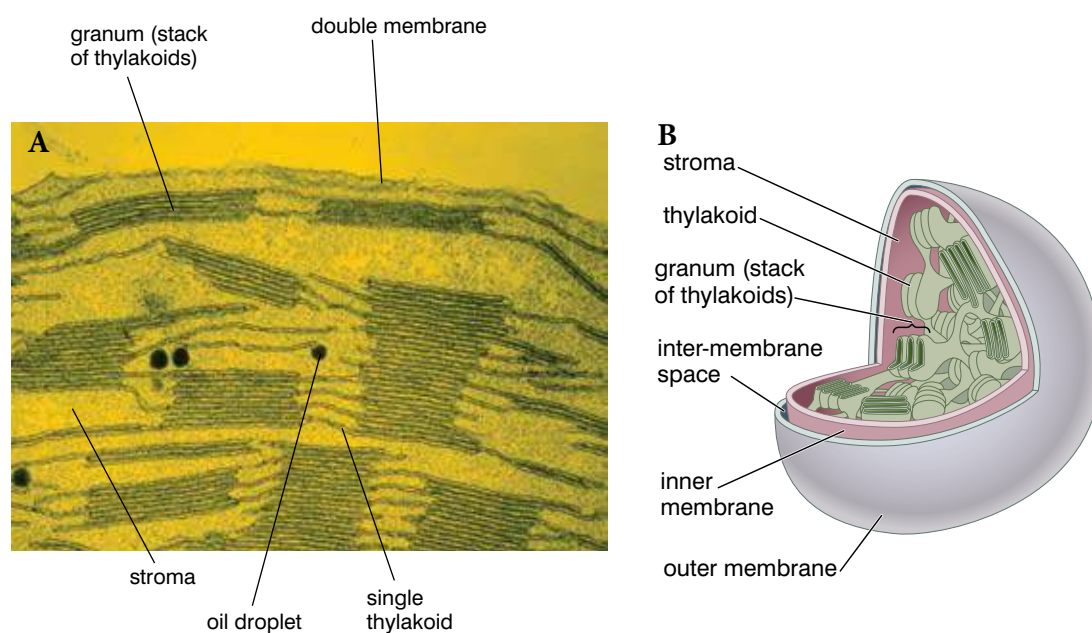
**photosensitive pigments** *pigments having a response to light*

**chlorophyll** *green pigment that absorbs blue and red light*

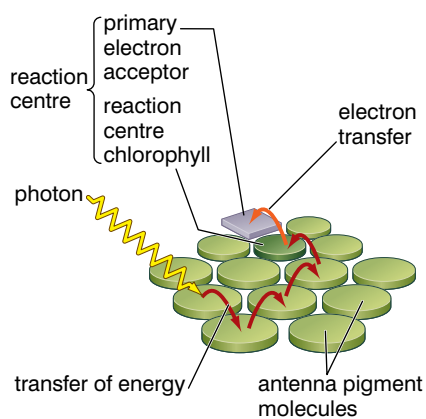
**thylakoids** *flattened sacs inside a chloroplast on which light-dependent reactions of photosynthesis take place*

**photosystems** *biochemical mechanism by which chlorophyll absorbs light energy*

**photosystem I** *photosystem in photosynthetic light reactions. Discovered before photosystem II*



**Figure 5.29** The structure of a chloroplast: **A** A transmission electron micrograph of a section through a chloroplast; **B** A three-dimensional representation of the structure of a chloroplast

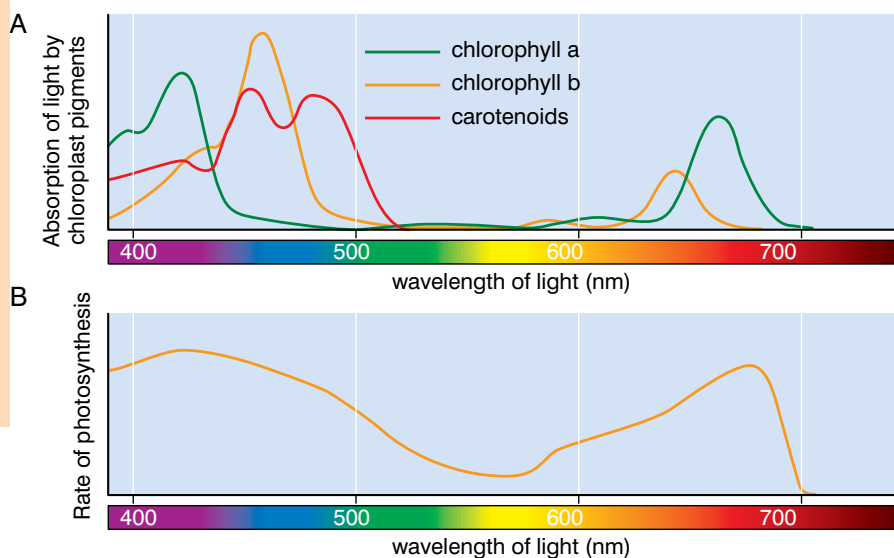


**Figure 5.30** The structure of a photosystem

### Activity 5.9

Draw and label the structure of a chloroplast, showing where the light-dependent and the light-independent reactions take place.

Compare this diagram to the one you made earlier of a chloroplast and describe the similarities and differences between these two organelles.



**Figure 5.31A** The absorption spectrum of chlorophyll a, chlorophyll b and carotenoids. Notice how between them they absorb most wavelengths of visible light – except 500 nm to 600 nm – green! Plants are green because these wavelengths are reflected, not absorbed; **B** The action spectrum for different wavelengths of light. Notice the dip in the ‘green’ region of the spectrum

### KEY WORDS

**reaction centre molecule** where light-dependent reactions begin

**antenna complex** an array of protein and chlorophyll light-harvesting molecules embedded in the thylakoid membrane

**absorption spectrum** the range of wavelengths a molecule absorbs

**action spectrum** the photosynthesis effectiveness of each wavelength

## What is the structure of a photosystem?

A photosystem consists of a number of pigment molecules all clustered around one particular chlorophyll molecule called the reaction centre molecule. This cluster of pigment molecules is called an antenna complex. Only the reaction centre molecule is positioned next to the electron transport chain. Energy absorbed by other molecules in the photosystem is transferred to the **reaction centre molecule**, where the light-dependent reactions begin. Different pigment molecules in the **antenna complex** can absorb different wavelengths of light, making the whole system more efficient. The pigments in the antenna complex include chlorophyll a, chlorophyll b and carotenoids. The reaction centre molecule is always chlorophyll a. The range of wavelengths each molecule absorbs is its **absorption spectrum**. Figure 5.31A shows the absorption spectrum of chlorophyll a, chlorophyll b and carotenoids. Figure 5.31B shows the **action spectrum** for different wavelengths of light. This shows how effective photosynthesis is at each wavelength.

## What happens in the light-dependent reactions?

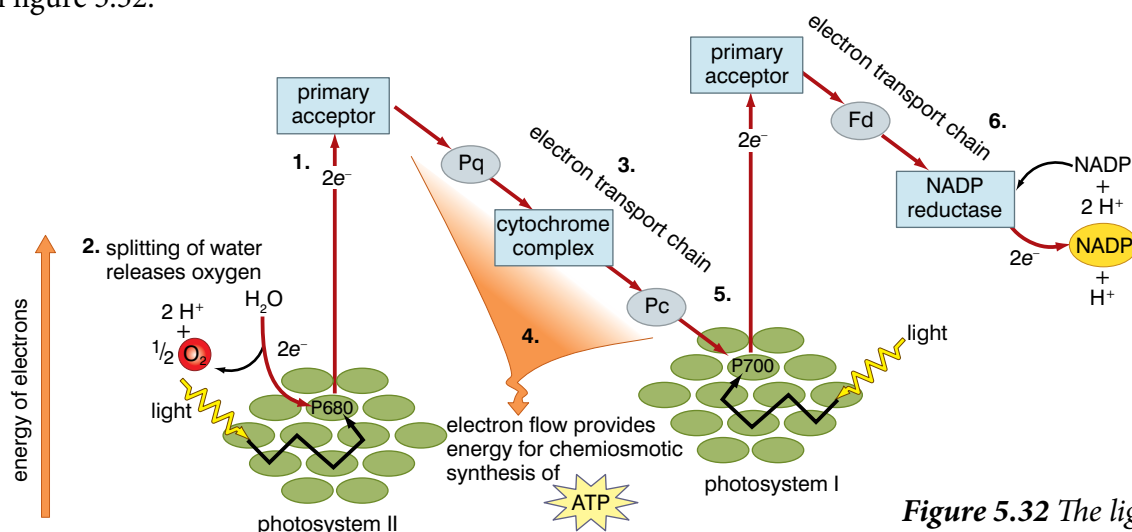
The light-dependent reactions use light energy to ‘drive’ the synthesis of two molecules that will, in turn, drive the light-independent reactions. These two molecules are:

- ATP – this provides the energy for the reactions, and
- reduced NADP – this provides the hydrogen ions for a key reduction reaction.

NADP is very similar to NAD that is used in respiration and it has the same function – transporting hydrogen ions.



The main events in the light-dependent reactions are summarised in figure 5.32.



**Figure 5.32** The light-dependent reactions of photosynthesis

## Photosystem I and photosystem II

- Electrons (e<sup>-</sup>) in chlorophyll molecules in photosystem II are excited by the energy in photons of light – they become more energetic. Because of the extra energy, they escape from the chlorophyll and pass to an electron acceptor (the **primary electron acceptor**).
- The conditions created in the chloroplast cause the following reaction to occur:
 
$$2\text{H}_2\text{O} \rightarrow \text{O}_2 + 4\text{H}^+ + 4\text{e}^-$$
 This light-dependent splitting of water is called **photolysis**. The electrons replace those lost from the chlorophyll molecule.
- The primary electron acceptor passes the electrons to the next molecule in an electron transport chain (plastoquinone or 'Pq'). The electrons then pass along a series of cytochromes (similar to those in the mitochondrial electron transport chain) and finally to plastocyanin (Pc) – the last carrier in the chain. The electrons lose energy as they are passed from one carrier to the next.
- One of the molecules in the cytochromes complex is a proton (hydrogen ion) pump. As electrons are transferred to and then transferred from this molecule, the energy they lose powers the pump which moves protons from the stroma of the chloroplast to the space inside the thylakoid. This leads to an accumulation of protons inside the thylakoid, which drives the chemiosmotic synthesis of ATP.
- Electrons in chlorophyll molecules in photosystem I are excited (as this photosystem absorbs photons of light) and escape from the molecule. They are replaced by the electrons that have passed down the electron transport chain from photosystem II.
- The electrons then pass along a second electron transport chain involving ferredoxin (Fd) and NADP reductase. At the end

### DID YOU KNOW?

The chlorophyll a molecule in photosystem II is most active with light of wavelength of 680 nm (P680); that in photosystem I is most active with light of a wavelength of 700 nm (P700).

### KEY WORDS

**primary electron acceptor**  
*the first molecule to accept the excited electron displaced from a chlorophyll molecule*

**photolysis** *light-dependent splitting of water*

**KEY WORDS**

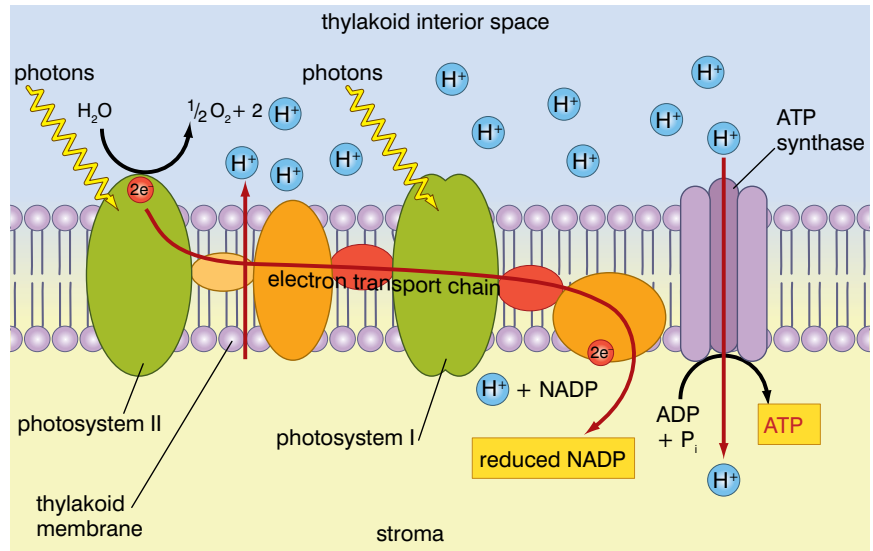
**photosynthetic unit** *an arrangement of molecules capable of carrying out all the reactions in the light-dependent stage of photosynthesis.*

**non-cyclic photophosphorylation** *the formation of ATP via photosystem II*

**cyclic photophosphorylation** *use of only photosystem I to generate ATP*

of this electron transport chain, they can react with protons (hydrogen ions) and NADP in the stroma of the chloroplast to form reduced NADP.

Figure 5.32 is part graph and part flow chart showing how the reactions take place and in what sequence. But it doesn't show how the molecules are arranged in relation to each other to form what is called a **photosynthetic unit**. Figure 5.33 shows this arrangement.

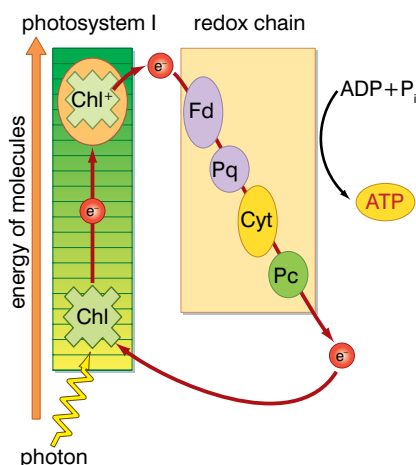


**Figure 5.33** How the molecules are arranged in a photosynthetic unit

A photosynthetic unit is a unit of pigments, electron carriers and ATP synthase that is capable of carrying out all the reactions in the light-dependent stage of photosynthesis. The formation of ATP in the way described above is called **non-cyclic photophosphorylation**. This is because:

- the phosphorylation (formation of ATP) is light-dependent
- the electrons lost from the chlorophyll are not recycled in any way

Plants sometimes generate ATP by **cyclic photophosphorylation**. In cyclic photophosphorylation, only photosystem I is used. No oxygen and no reduced NADP are formed. Figure 5.34 shows this system. Here, you can see that electrons lost from the chlorophyll molecule are returned to it. Hence the name 'cyclic'. This process usually only happens when sugars cannot be synthesised for some reason – such as lack of carbon dioxide.



**Figure 5.34** Cyclic photophosphorylation

In cyclic and non-cyclic photophosphorylation, ATP is produced because:

- there is an accumulation of protons (hydrogen ions) in the interior of a thylakoid
- this creates a concentration gradient between the thylakoid interior and the stroma of the chloroplast
- protons move down this concentration gradient, through ATP synthase, causing the rotor to spin, just as in mitochondria during respiration

### A summary of the light-dependent reactions

Light energy is used to excite electrons which then:

- cause the transfer of protons to the inside of the thylakoid membrane as they pass along the first electron transport chain; this eventually leads to the formation of ATP, and
- react with hydrogen ions and NADP at the end of the second electron transport chain to form reduced NADP; this reaction could only happen because of the extra energy possessed by the electrons.

The ATP and reduced NADP are used to drive the synthesis of carbohydrates in the light-independent reactions of photosynthesis.

### Activity 5.10: Separate the photosynthetic pigments in spinach leaves

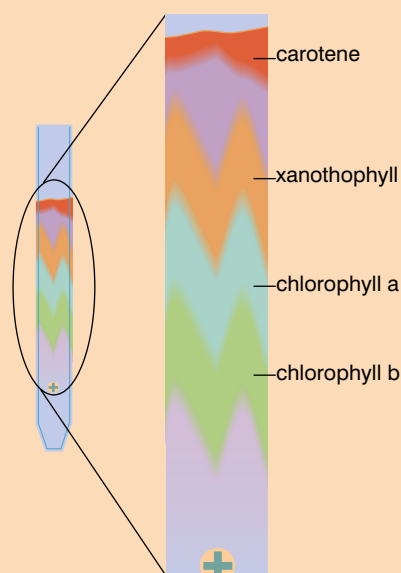
#### You will need:

- spinach (or other) leaves
- pestle and mortar
- 80% acetone
- calcium carbonate
- filter funnel, beaker, measuring cylinder, glass jar with a tight cork
- no.1 filter paper, petroleum ether, acetone, hook, micropipette

#### Method

1. Take 50 g of fresh spinach leaves in a pestle and mortar. Grind them with 20 ml of 80% acetone.
2. Add a pinch of calcium carbonate and again crush.
3. Filter the extract. The deep-green-coloured filtrate contains the photosynthetic pigments (chlorophylls, carotenoids and xanthophylls).
4. Take a glass jar (about 45 cm high) with a tight cork fitted in it. The cork should have a hole in the centre.
5. Mix 25 cm<sup>3</sup> petroleum ether and 3 cm<sup>3</sup> acetone. Pour the solvent into the jar and allow the jar to become saturated.
6. Cut a strip of filter paper of the size which will fit in the jar.
7. Mark a pencil line about 3 cm from one end.
8. Place a small circular spot of pigment extract on the pencil line.
9. Allow the spot to dry and add another spot in the same place.
10. Repeat stages 8 and 9 several times until you have a concentrated spot – but do not let the spot ‘spread’ too far whilst you are preparing it.
11. Now hang the strip inside the jar (you could tape it to the base of the cork) and close the cork. DO NOT ALLOW THE SPOT TO DIP INTO THE SOLVENT.
12. Allow the chromatogram to run until the solvent has nearly reached the top of the filter paper. DO NOT LET THE SOLVENT RUN TO THE TOP OF THE FILTER PAPER.

You should see something like the distribution of pigments shown in figure 5.35.



**Figure 5.35** A chromatogram of the pigments in spinach leaves

## KEY WORDS

**ribulose biphosphate** a five-carbon compound in the stroma

## DID YOU KNOW?

**About Rubisco**

The full name for the enzyme is ribulose biphosphate carboxylase oxygenase. Notice that there are two '-ases' in the name. Rubisco can catalyse the addition of  $\text{CO}_2$  or  $\text{O}_2$  to ribulose biphosphate. It is unusual for an enzyme to be able to catalyse two reactions involving different substrates. We shall see the importance of this when we study photorespiration later.

## How is carbohydrate synthesised in the light-independent reactions?

The light-independent reactions of photosynthesis occur in the stroma of the chloroplasts. They comprise a complex cycle of reactions that involves the addition of carbon dioxide to a pre-existing five-carbon molecule (a molecule containing five carbon atoms) within the chloroplast. The resulting molecules are modified to regenerate the original molecule whilst, at the same time, synthesising glucose. The sequence of reactions was discovered by Melvin Calvin, an American biologist. Because of his work, the light-independent reactions are also referred to as the Calvin cycle.

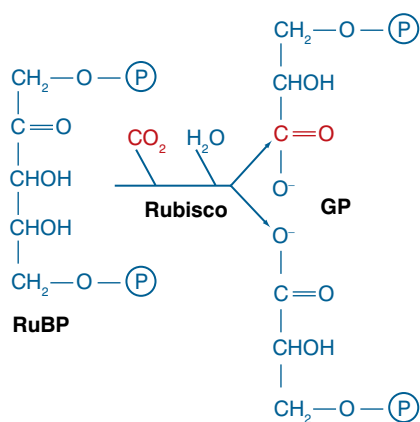
In the 1950s Melvin Calvin experimented with unicellular algae called *Chlorella* by exposing them to radioactive carbon dioxide.

After different periods of time, the algae were killed and the chemicals in the algae that contained radioactive carbon (which must have come from the carbon dioxide) were identified using two-dimensional chromatography.

As time passes more compounds contain the radioactive carbon. By refining the experiment and using shorter and shorter intervals, Calvin identified the first stable compound to be formed as a compound containing three carbon atoms called glycerate phosphate (GP).

The main stages of the light-independent reactions are:

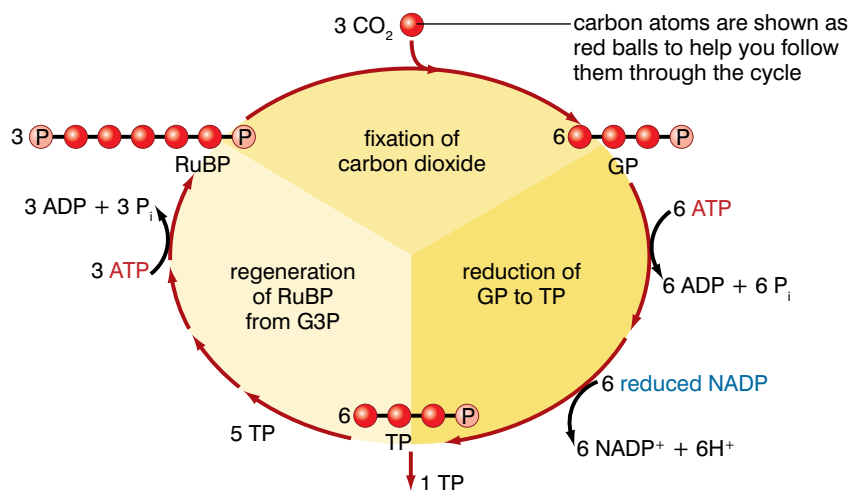
- carbon dioxide reacts with **ribulose biphosphate (RuBP)** – a five-carbon compound in the stroma; the reaction is catalysed by the enzyme **Rubisco**.
- two molecules of the three-carbon compound GP are formed from this reaction as figure 5.36 shows
- each molecule of GP is converted to TP (triose phosphate – another three-carbon compound); this is a reduction reaction using hydrogen ions from reduced NADP and energy from ATP
- some of the TP formed is used to regenerate the RuBP (ATP is again required) whilst some is used to form glucose and other useful organic compounds



**Figure 5.36** The action of Rubisco

Figure 5.37 summarises the light-independent reactions of photosynthesis. It shows how three 'turns of the cycle' result in an output of one molecule of TP. Six turns of the cycle would give an output of two molecules of TP – enough to make one molecule of glucose.

TP can also be converted to lipids, amino acids and from these into nucleotides and all the other organic molecules found in plants. TP is the basis for the synthesis of all organic molecules.

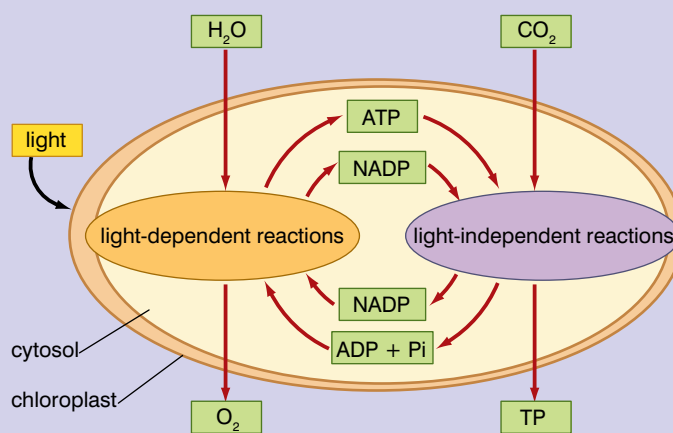


**Figure 5.37** The light-independent reactions

**DID YOU KNOW?**

**How the light-dependent and light-independent reactions are related**

During the light-independent reactions, reduced NADP is reoxidised to NADP and ATP is hydrolysed to ADP and  $P_i$ . These are then reused in the light-dependent reactions to regenerate ATP and reduced NADP to be used again in the light-independent reactions ... and so on. Figure 5.38 summarises the relationship between the light-dependent reactions and the light-independent reactions.



**Figure 5.38** The relationship between the light-dependent and light-independent reactions

**What factors affect the rate of photosynthesis?**

Photosynthesis is dependent on a number of factors. The main ones, and their effects, are shown in the table below.

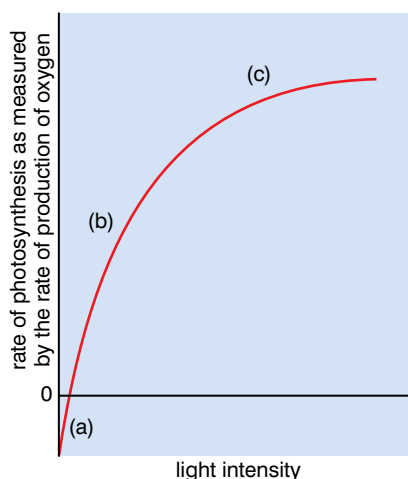
**Table 5.1** Factors affecting the rate of photosynthesis

Factor	Effect on photosynthesis
Light intensity	Low light intensity can limit the light-dependent reactions by reducing the number of electrons in chlorophyll molecules that are photo-excited.
Carbon dioxide concentration	Can limit the light-independent reactions by influencing the rate of the initial reaction with RuBP.
Temperature	Can limit the rate of enzyme action, for example, ATP synthase (light-dependent reactions) and Rubisco (light-independent reactions).

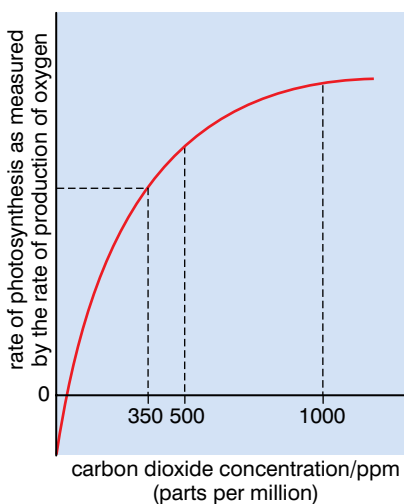
**DID YOU KNOW?**

**About the optimum temperatures of enzymes controlling photosynthesis**

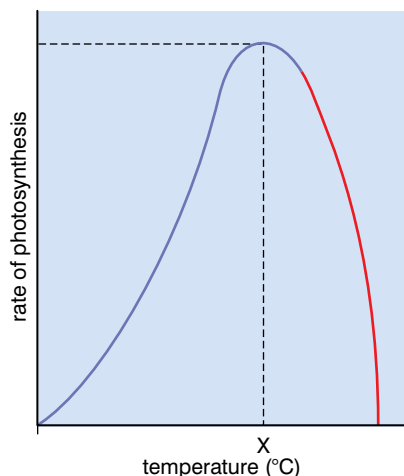
The actual optimum temperature for the enzymes of photosynthesis varies with the geographical location. The enzymes of plants that live within the Arctic Circle have a much lower optimum than those of plants found in the tropics.



**Figure 5.39** The effect of light intensity on the rate of photosynthesis (measured by the rate of production of oxygen)



**Figure 5.40** The effect of carbon dioxide on the rate of photosynthesis



**Figure 5.41** The effect of temperature on the rate of photosynthesis

In table 5.1, you can see that there is a reference to the factors ‘limiting’ the rate of photosynthesis when their presence is in short supply. But which factor actually limits the rate of photosynthesis? The answer to this question could well be different on different days. On a cold, bright day in an Arctic country, temperature is likely to hold back the rate of photosynthesis. On a warm, cloudy day in summer, light intensity is likely to limit the rate. On a warm, sunny day in summer, it could well be the concentration of carbon dioxide. In general terms we can say that:

The rate of photosynthesis is limited by the factor that is present in a limiting quantity.

This is known as the **principle of limiting factors**.

### What is the effect of light intensity on the rate of photosynthesis?

This is shown as a graph in figure 5.39. The graph is divided into three regions:

- very low light intensities – respiration is still occurring and is taking in oxygen faster than photosynthesis is producing it
- medium light intensities – photosynthesis is producing more oxygen than respiration uses, the rate of photosynthesis increases with increasing light intensity
- very high light intensities – the rate of photosynthesis is beginning to level out, even though the light intensity is still increasing; some other factor is probably limiting the rate

### What is the effect of the concentration of carbon dioxide on the rate of photosynthesis?

Again, it is convenient to show this as a graph (figure 5.40). The graph is similar to that in figure 5.39. At very low concentrations of carbon dioxide, little photosynthesis takes place, although respiration is still using up oxygen. As the carbon dioxide concentration increases, so does the rate of photosynthesis. Again, however, it begins to level off at higher concentrations. This may be due to some other factor, or it could be due to the saturation of Rubisco.

### How does temperature affect the rate of photosynthesis?

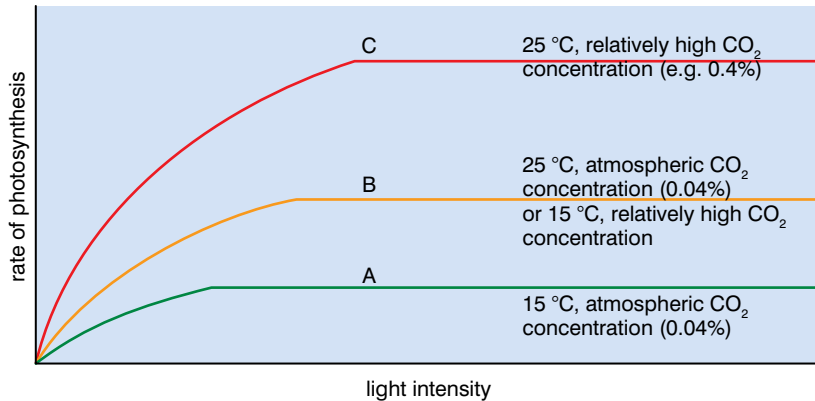
Many of the reactions in both the light-dependent stage and the light-independent stage are controlled by enzymes, which are affected by temperature. Once the temperature exceeds the optimum, the enzyme denatures and the rate of photosynthesis decreases rapidly.

### How can all the factors interact to influence the rate of photosynthesis?

Increasing the light intensity should increase the rate at which ATP and reduced NADP are produced in the light-dependent reactions and, as a result, increase the rate at which the Calvin cycle can take place. However, the rate at which the Calvin cycle can ‘turn’ could be limited by:

- a low temperature (limiting the rate at which enzymes such as Rubisco can operate)
- a low concentration of carbon dioxide

This limits the rate at which reduced NADP and ATP can be used, which, in turn, limits the amount of NADP and ADP + P<sub>i</sub> that can be reused by the light-dependent reactions. The whole process is therefore limited, even though the light intensity continues to increase. This is shown in figure 5.42.

**KEY WORD**

**principle of limiting factors**  
*limitation by a factor that is present in a limiting quantity*

**Figure 5.42** The effect of several factors on the rate of photosynthesis

In the region of the graphs where light is non-limiting (horizontal lines), the factors that are limiting are:

- A – both temperature and carbon dioxide; increasing either produces an increase in the rate of photosynthesis to level B
- B – temperature or carbon dioxide concentration (the factor that hasn't been increased from A); increasing the temperature increases the rate to level C

As well as the major factors discussed above, a number of other factors influence the rate of photosynthesis. These include:

- the wavelength of the light; photosynthesis takes place faster in 'red' and 'blue' wavelengths than in other wavelengths because these wavelengths are absorbed more efficiently than others; leaves are green because green wavelengths are reflected
- the amount of chlorophyll present

**DID YOU KNOW?****That commercial growers make use of the law of limiting factors**

Crops are often grown in large glass 'greenhouses' or in even larger 'polytunnels'.

In both cases the crops are effectively grown in an indoor, controlled environment covered in a transparent material to allow light to penetrate. Here, growers can apply knowledge of the principle of limiting factors to enhance photosynthesis and, therefore, the yield of the crop. Increasing the carbon dioxide concentration and increasing the temperature (up to a point) can increase both the rate of photosynthesis and, therefore, the yield of the crop.



**Figure 5.43** Crop plants being grown in a polytunnel

Just enclosing the plants in a greenhouse or polytunnel will increase the temperature (because of the 'greenhouse effect') without any extra heating costs. However, this will only happen during daylight hours. At night, the greenhouse will cool down and growth processes other than photosynthesis will also slow down.

However, before investing in any equipment

to maintain increased temperatures and carbon dioxide concentrations, the grower needs to be aware of the likely gains. He/she needs to ask what will be the extra yield:

- from increasing the concentration of carbon dioxide?
- from increasing the temperature?

And will the extra cost of this be offset by extra profits?

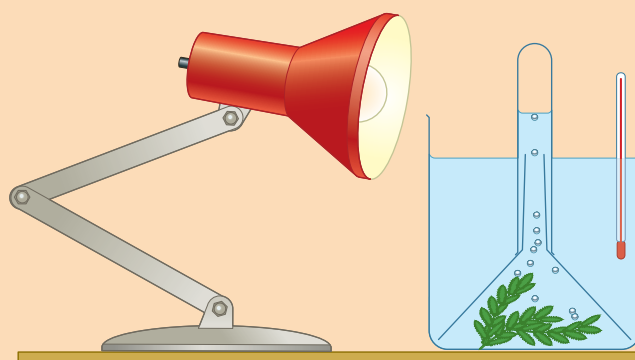
### Activity 5.11: Investigating the rate of photosynthesis

The rate of photosynthesis can be measured in some aquatic plants by collecting the oxygen given off in a certain period of time. The diagram below shows a simple apparatus for collecting the oxygen produced by *Elodea* – a pond weed.

The lamp is to make sure that the plant is illuminated constantly for 24 hours. Carbon dioxide is supplied by dissolving sodium hydrogen carbonate in the water. In solution, the sodium hydrogen carbonate releases carbon dioxide over a period of time.

You can use this simple apparatus to plan investigations into:

- the effect of temperature on the rate of photosynthesis
- the effect of carbon dioxide concentration on the rate of photosynthesis
- the effect of light intensity on the rate of photosynthesis



**Figure 5.44** Investigating the effect of light intensity on the rate of photosynthesis

In your plans, you must make clear:

- how you will change the independent variable
- how you will measure the dependent variable
- how you will control other variables that might influence your results
- the steps you will take to ensure that your results are as reliable as possible

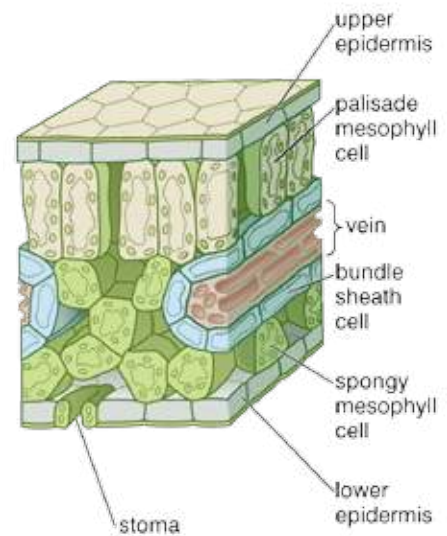
### Are there any other ways of photosynthesising?

#### C3 photosynthesis and photorespiration

What we have just described is the method of photosynthesis that takes place in plants living in temperate environments, such as those found in Europe. It is called C3 photosynthesis – because the first compound formed in the light-independent reactions of the Calvin cycle is GP, which contains three carbon atoms. C3 plants have leaves that are adapted to this method of photosynthesis. These leaves are generally broad, to catch as much sunlight as possible.

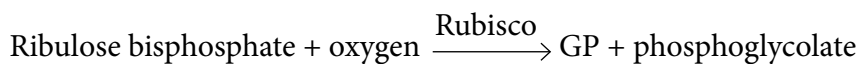


The cells that contain most chloroplasts (the palisade cells) are nearest the upper surface of the leaf (to absorb as much light as possible). The stomata are mainly on the lower surface, to minimise water loss. During the day, the stomata are open for most of the time to allow the entry of carbon dioxide, but they can be closed if the water loss is too great on a hot day. The spongy mesophyll has air spaces that allow easy diffusion of carbon dioxide and oxygen between the palisade layer and the stomata. Figure 5.45 shows the structure of the leaf of a C<sub>3</sub> plant.



**Figure 5.45** A leaf from a C<sub>3</sub> plant

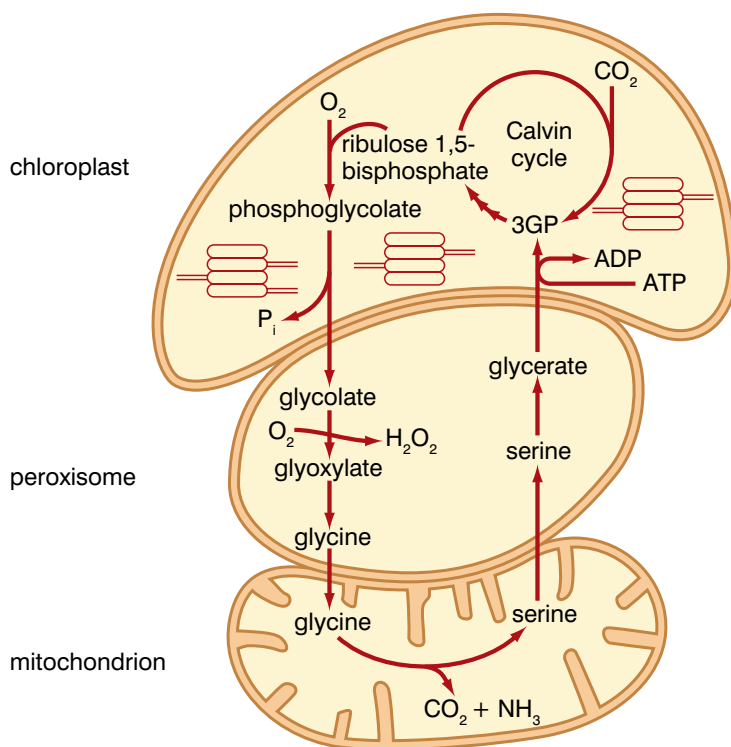
However, plants in the tropics have a problem. Here, it can be very hot and the leaves close their stomata to minimise water loss. When C<sub>3</sub> plants do this, the concentration of carbon dioxide in the leaves falls and the enzyme Rubisco starts to behave in an unusual way. In the low concentrations of carbon dioxide, Rubisco binds with oxygen, not carbon dioxide. This means that RuBP is oxidised to one molecule of GP (not two) and a molecule of phosphoglycolate. In addition, carbon dioxide is produced in the process. The process is called **photorespiration** because it involves oxidation of carbon.



The one molecule of GP formed in photorespiration can re-enter the Calvin cycle, but the phosphoglycolate must be converted into GP for use in the Calvin cycle by a complex series of reactions. These reactions (involving a chloroplast, an organelle called a peroxisome and a mitochondrion) are summarised in figure 5.46

#### KEY WORD

**photorespiration process**  
involving the oxidation of carbon



**Figure 5.46** The reactions of photorespiration

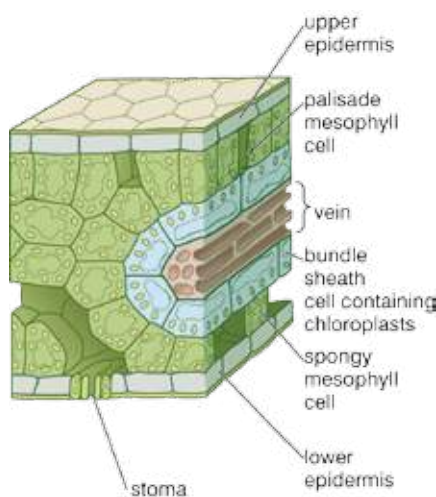
#### DID YOU KNOW?

**Why peroxisomes are named this way**

It is because they produce and then break down hydrogen **peroxide**.

**KEY WORD**

**C4 photosynthesis** *light-dependent reactions are the same as in C3 photosynthesis but the first compound formed in the light-independent reactions contains four carbons, not three*



**Figure 5.47** The structure of a leaf from a C4 plant

**Activity 5.12**

List as many C4 plants that grow in Ethiopia as you can – you can use your textbook and the library, ask your teacher and use the internet if it is available to help you find as many as possible.

It is not necessary to try to remember all these reactions. Instead, think of the two phases of photorespiration:

1. Rubisco catalyses a reaction between oxygen and RuBP to form one molecule of GP (not two) and one molecule of phosphoglycolate.
2. The phosphoglycolate is converted to GP in reactions in the chloroplast, peroxisome and mitochondrion.

Photorespiration reduces the efficiency of photosynthesis for several reasons, including:

- the carbon is oxidised, which is the reverse of photosynthesis – the reduction of carbon to carbohydrate
- the ribulose biphosphate must be resynthesised and the phosphoglycolate removed
- ATP is used in the resynthesis of RuBP.

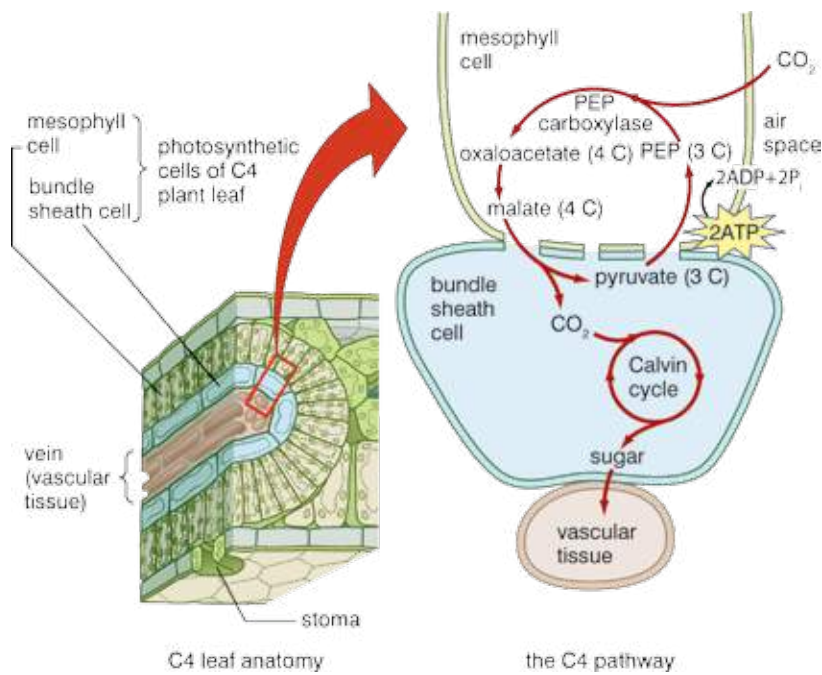
**C4 photosynthesis**

To get round the problem of photorespiration reducing the efficiency of photosynthesis, plants that grow in tropical areas like Ethiopia (such as maize, crabgrass, sorghum and sugar cane) have evolved a different photosynthetic pathway called **C4 photosynthesis**.

As the name suggests, the first compound formed in the light-independent reactions is a C4 compound (contains four carbon atoms) not GP (a C3 compound). The light-dependent reactions are the same as in the C3 plants, but there is a difference in how glucose is synthesised in the light-independent reactions. First, look at the structure of the leaf of a C4 plant in figure 5.47. The structure is essentially similar to that of a C3 plant, but there is one important difference. The cells of the bundle sheath contain chloroplasts, which they don't in C3 plants. Having no thylakoids means that the light-dependent reactions cannot occur here and so oxygen is not produced in these chloroplasts. This helps to prevent photorespiration and allows the Calvin cycle to take place in these cells.

The light-dependent reactions in the C4 pathway also involve a set of reactions not found in C3 plants. These reactions take place in the mesophyll cells, which have chloroplasts with thylakoids and so can carry out the light-dependent reactions. However, they do not have the enzymes to catalyse the reactions of the Calvin cycle. Instead, the following reactions take place:

1. Carbon dioxide reacts with a C3 compound called PEP to form the C4 compound oxaloacetate. This is catalysed by the enzyme PEP carboxylase.
2. Oxaloacetate is converted into another C4 compound (malate), which then passes from the mesophyll cell into a bundle sheath cell.



### DID YOU KNOW?

#### Why C4 plants experience a low concentration of carbon dioxide

This is not because the composition of air in tropical regions is any different from that in other regions. It is because C4 plants (grasses, maize) often grow very close together and so compete for the carbon dioxide in the air, reducing its concentration.

**Figure 5.48** The light-independent reactions of the C4 pathway of photosynthesis

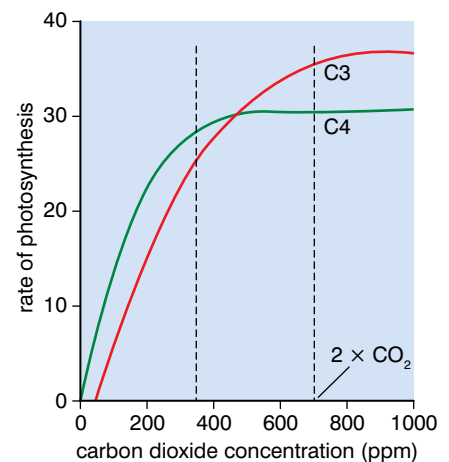
- In the bundle sheath cell, malate is converted to pyruvate with the release of a molecule of carbon dioxide, which starts the reactions of the Calvin cycle by binding with RuBP.
- The pyruvate is converted back to PEP; this reaction requires ATP. These reactions are summarised in figure 5.48.

Overall, the C4 cycle uses two more molecules of ATP to deliver a molecule of carbon dioxide to Rubisco than does the C3 cycle. During active photosynthesis in the tropics, this is not a problem, as the high light intensity generates much ATP from the light-dependent reactions.

C4 photosynthesis is most efficient in conditions of:

- low carbon dioxide concentration
- high light intensity
- high temperature

Figure 5.49 compares the efficiency of C3 and C4 photosynthesis under different concentrations of carbon dioxide.



**Figure 5.49** The efficiency of C3 and C4 photosynthesis at different carbon dioxide concentrations

DID YOU KNOW?

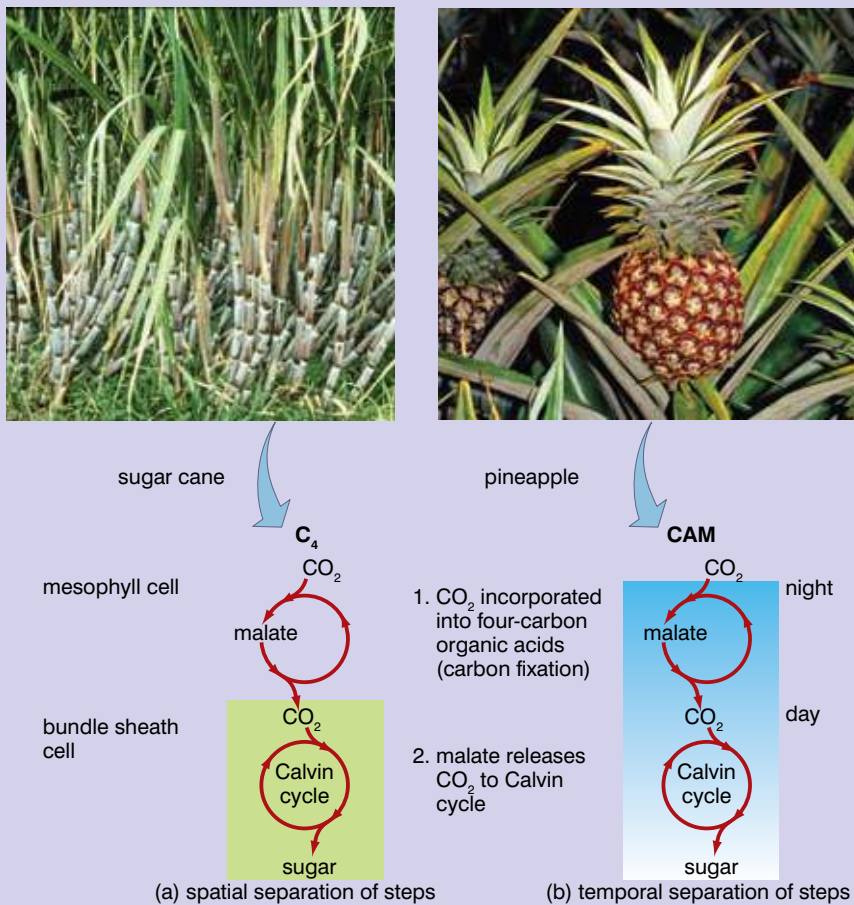
**Cacti do it yet another way!**

In the extreme heat of deserts, having stomata open during the day is a sure path to desiccation and death for the plants. But if they don't open their stomata, how will they get the carbon dioxide they need for photosynthesis? The answer is obvious really – open them at night when temperatures fall.

Cacti use what is essentially the same set of reactions as C<sub>4</sub> plants, but they separate the two stages not by carrying them out in different cells, but by carrying them out at different times. The CAM photosynthesis cycle is as follows:

1. At night, the plants open their stomata to allow in CO<sub>2</sub>, which then reacts with PEP in mesophyll cells to form oxaloacetate, and then malate just as in the C<sub>4</sub> pathway.
2. The malate is then stored in the vacuoles of these cells overnight.
3. During the day, the light-dependent reactions generate ATP and reduced NADP so that the Calvin cycle can continue.
4. Malate is released from the vacuoles and is broken down to glycerate, releasing carbon dioxide for the reactions of the Calvin cycle.

Figure 5.50 compares the C<sub>4</sub> pathway and the CAM pathway.



**Figure 5.50** The C<sub>4</sub> and CAM photosynthetic pathways

Table 5.2 compares several aspects of the two processes.

**Table 5.2** A comparison of C3 and C4 photosynthesis

Feature	C3	C4
Bundle sheath cells	Lack chloroplasts	Have chloroplasts with no thylakoids
Enzyme used to fix CO <sub>2</sub>	Rubisco	Pepco (PEP carboxylase)
Optimum temperature	15–25 °C	30–40 °C
Optimum CO <sub>2</sub> concentration	700 ppm	400 ppm
Fixation of CO <sub>2</sub>	Mesophyll cells	Mesophyll cells
Calvin cycle	Mesophyll cells	Bundle sheath cells

The crop plants that are grown in Ethiopia (such as sorghum and wheat) are all C4 plants and are, therefore, well adapted to photosynthesise efficiently in the hot, bright days found in this country. Crop plants that are grown in temperate areas (such as peas and carrots) would not photosynthesise as efficiently, because they are C3 plants. They would, therefore, not produce high yields.

### Activity 5.13: presentations on aspects of photosynthesis

In this activity, you will be divided into groups to prepare a presentation on some aspect of photosynthesis.

The main aspects that different groups will cover are:

- the light-harvesting complex of pigments
- the light dependent reactions
- the light independent reactions
- photorespiration
- C3 and C4 photosynthesis

Each group should:

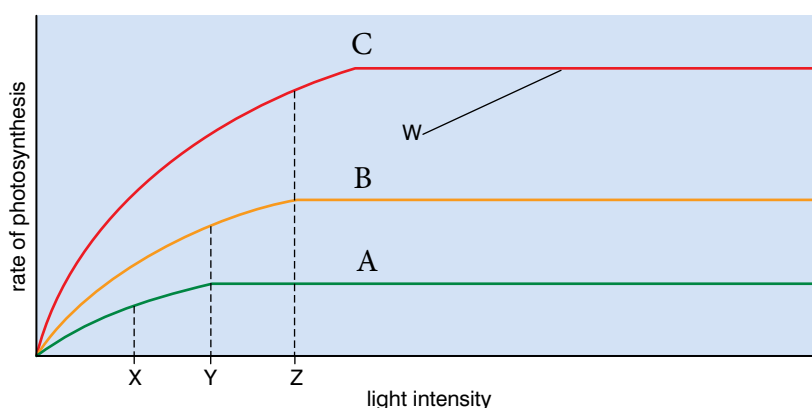
- concentrate on the main features of their assigned task (it is important not to over-complicate your presentation)
- present these in a manner that will be easily recognised and easily understood by those members of the class who have not made a detailed study of your aspect of photosynthesis
- include visual material to break up any text that they present
- try to keep their presentation brief – keep to five minutes if possible

## Review questions

Choose the correct answer from A to D.

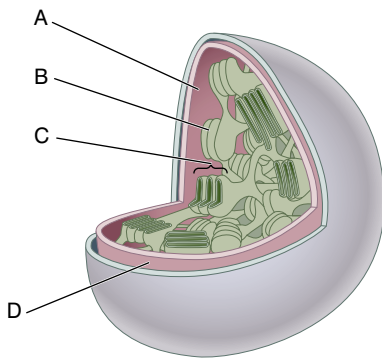
- In the light-dependent reactions of photosynthesis:
  - NADP is reduced
  - ATP is produced
  - ADP is produced
  - Light energy excites chlorophyll electrons

Figure 5.51 shows the effect of light intensity on the rate of photosynthesis at different concentrations of carbon dioxide and at different temperatures. Questions 2 and 3 relate to this graph.



**Figure 5.51**

- Line B could represent:
  - low carbon dioxide concentration and high temperature
  - low carbon dioxide and low temperature
  - high carbon dioxide and high temperature
  - any of the above
- Which region of the graph, W, X, Y or Z, represents conditions in which light intensity is not limiting the rate of photosynthesis?
  - W
  - X
  - Y
  - Z
- In the light-independent reactions of photosynthesis:
  - ATP is used to convert GP into TP
  - reduced NADP is used to convert GP into TP
  - ATP is produced
  - carbohydrates are produced



**Figure 5.52** Structure of a chloroplast

Figure 5.42 shows the structure of a chloroplast. Questions 5 and 6 relate to this diagram.

5. During the light-dependent reactions of photosynthesis, ATP is produced in the regions labelled:
  - A A
  - B B
  - C C
  - D D
6. NADP moves from:
  - A A to B
  - B B to A
  - C B to C
  - D C to A
7. Cyclic photophosphorylation produces:
  - A oxygen and ATP
  - B reduced NADP and ATP
  - C oxygen only
  - D ATP only
8. In the light-independent reactions, reduced NADP is used to:
  - A oxidise GP to TP
  - B oxidise TP to GP
  - C reduce TP to GP
  - D reduce GP to TP
9. A photosynthetic unit can carry out:
  - A photolysis
  - B the synthesis of ATP
  - C the synthesis of reduced NADP
  - D all of the above
10. A photosystem consists of:
  - A a reaction centre molecule and an electron transport chain
  - B a reaction centre molecule and an antenna complex
  - C an accessory pigment and an antenna complex
  - D an accessory pigment and an electron transport chain

**Activity 5.14**

Make a big poster to show the Calvin cycle in photosynthesis. Have an inset area to show cyclic and non-cyclic photophosphorylation and how it fits in with the production of sugars.

11. In photorespiration:
  - A low oxygen concentrations cause Rubisco to form more GP than usual
  - B low oxygen concentrations cause Rubisco to form less GP than usual
  - C low carbon dioxide concentrations cause Rubisco to form less GP than usual
  - D low carbon dioxide concentrations cause Rubisco to form more GP than usual
12. In the C<sub>4</sub> pathway:
  - A PEP carboxylase catalyses the reaction of carbon dioxide with RuBP in the mesophyll cells
  - B PEP carboxylase catalyses the reaction of carbon dioxide with RuBP in the bundle sheath cells
  - C PEP carboxylase catalyses the reaction of carbon dioxide with PEP in the mesophyll cells
  - D PEP carboxylase catalyses the reaction of carbon dioxide with PEP in the bundle sheath cells
13. C<sub>4</sub> photosynthesis is more efficient than C<sub>3</sub> photosynthesis in conditions of:
  - A high light intensity and high carbon dioxide concentrations
  - B low light intensity and high carbon dioxide concentrations
  - C high light intensity and low carbon dioxide concentrations
  - D low light intensity and low carbon dioxide concentrations
14. The chloroplasts in the bundle sheath cells of C<sub>4</sub> plants are an adaptation to this pathway because:
  - A they contain no Calvin cycle enzymes
  - B they contain no thylakoids
  - C they have a large surface area
  - D they produce large amounts of oxygen
15. Which of the following statements about C<sub>4</sub> and CAM photosynthesis is true?
  - A In CAM photosynthesis, the C<sub>4</sub> stage and the Calvin cycle are separated in time.
  - B In CAM photosynthesis, the C<sub>4</sub> stage and the Calvin cycle are separated in space.
  - C In C<sub>4</sub> photosynthesis, the C<sub>4</sub> stage and the Calvin cycle are separated in time.
  - D In C<sub>4</sub> photosynthesis, the C<sub>4</sub> stage and the Calvin cycle both occur in the same cell.



## Summary

In this unit you have learnt that:

- ATP is an ideal energy-storage molecule in a cell because:
  - energy is released from the molecule quickly, in a single-step hydrolysis reaction
  - energy is released in small amounts (that are closely matched to the amounts needed for cellular reactions)
  - the molecule is easily moved around within the cell but cannot leave the cell
- The main stages of aerobic respiration are: glycolysis, the link reaction, the Krebs cycle, the electron transport chain and the chemiosmotic synthesis of ATP.
- In glycolysis, glucose (C<sub>6</sub>) is converted to pyruvate (C<sub>3</sub>) with the net gain of two molecules of ATP and two molecules of reduced NAD.
- In the link reaction, pyruvate is converted to acetyl coenzyme A (C<sub>2</sub>) with the loss of carbon dioxide and the production of two molecules of reduced NAD.
- In the Krebs cycle, acetyl coenzyme A combines with oxaloacetate (C<sub>4</sub>) to form citrate (C<sub>6</sub>), which is then decarboxylated to a C<sub>5</sub> compound and then to a C<sub>4</sub> compound, which is then converted into oxaloacetate; the cycle produces six molecules of reduced NAD, 2 molecules of reduced FAD and two molecules of ATP (by substrate level phosphorylation).
- As electrons from reduced NAD and reduced FAD pass along the electron transport chain they lose energy, which is used to pump protons from the matrix to the inter-membrane space.
- Protons then pass down an electrochemical gradient back into the mitochondrion through molecules of ATP synthase; each proton that passes through the enzyme causes one molecule of ATP to be synthesised.
- In fermentation (the anaerobic pathway):
  - the reactions of the electron transport chain, Krebs cycle and the link reaction cannot occur as, without oxygen as the terminal electron acceptor, NAD and FAD cannot be regenerated from reduced NAD and reduced FAD
  - glycolysis still occurs in anaerobic conditions as the NAD needed can be regenerated from reduced NAD by reducing pyruvate to lactate (animal cells) or ethanol (plant cells and yeast cells)
- Chloroplasts are well adapted to carry out photosynthesis because:
  - the grana provide a large surface area for the arrangement of chlorophyll molecules and the associated electron

- transport systems of the light-dependent reactions
  - the stroma provides a fluid medium for the reactions of the light-independent reactions
- The light-dependent reactions produce ATP and reduced NADP that are needed in the light-independent reactions.
- In the light-independent reactions:
  - $\text{CO}_2$  combines with RuBP (C5) to form two molecules of GP
  - GP is reduced to TP; reduced NADP supplies the hydrogen ions and ATP supplies the energy; the NADP and  $\text{ADP} + \text{P}_i$  are recycled to the light-dependent reactions
  - some TP is used to synthesise useful carbohydrates (such as glucose)
  - most TP is used to regenerate the RuBP so that the cycle of reactions can begin again
- The rate of photosynthesis is influenced by light intensity, concentration of carbon dioxide and temperature.
- The factor present in the lowest quantity will limit the rate of photosynthesis.
- When carbon dioxide concentrations fall, photorespiration can occur because oxygen then outcompetes carbon dioxide for the active site of Rubisco.
- Photorespiration reduces the efficiency of photosynthesis because:
  - only one molecule of GP is produced from RuBP
  - phosphoglycolate is produced which must be reconverted to RuBP, using up ATP
- C4 photosynthesis has evolved in plants in the tropics as a way of preventing photorespiration.
- In this process, the reactions of the Calvin cycle only take place in chloroplasts in bundle sheath cells.
- The bundle sheath cells can carry out the reactions of the Calvin cycle efficiently because:
  - they have no grana, so produce no oxygen to compete with carbon dioxide for the active site of Rubisco
  - there is a high concentration of carbon dioxide due to the decomposition of malate
- C4 photosynthesis is more efficient than C3 photosynthesis in conditions of high light intensity, high temperature and low carbon dioxide concentrations.
- CAM photosynthesis is effective in desert plants because it separates the light-dependent and light-independent stages in time; the leaves only open their stomata to allow the light-independent reactions to take place during the night, saving precious water.

## End of unit questions

- Describe how the structure of a chloroplast is suited to its function.
  - Describe *two* ways in which chloroplasts and mitochondria are:
    - similar
    - different
- Describe *three* ways in which the ATP molecule is suited to its function of energy carrier in a cell.
  - Describe how ATP is formed by:
    - substrate-level phosphorylation
    - chemiosmosis
- Figure 5.53 shows the structure of a chloroplast from a mesophyll cell of a C3 plant.
  - Name the parts labelled A, B, C and D.
  - Describe how the chloroplasts from a bundle sheath cell of a C4 plant would be different from this chloroplast. Explain the benefit to the plant of this difference.
- Make a drawing of apparatus you could use to measure the rate of fermentation of glucose by yeast.
  - Describe how you could use your apparatus to investigate the effect of temperature on the rate of fermentation in yeast. You must make clear in your account:
    - how you will change the temperature
    - how you will measure the rate of fermentation
    - how you will control other factors that might influence the results
- Figure 5.54 shows the light-dependent reactions of photosynthesis. Explain what is happening at each of the stages 1–6.

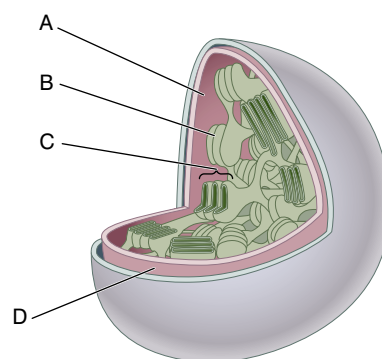


Figure 5.53

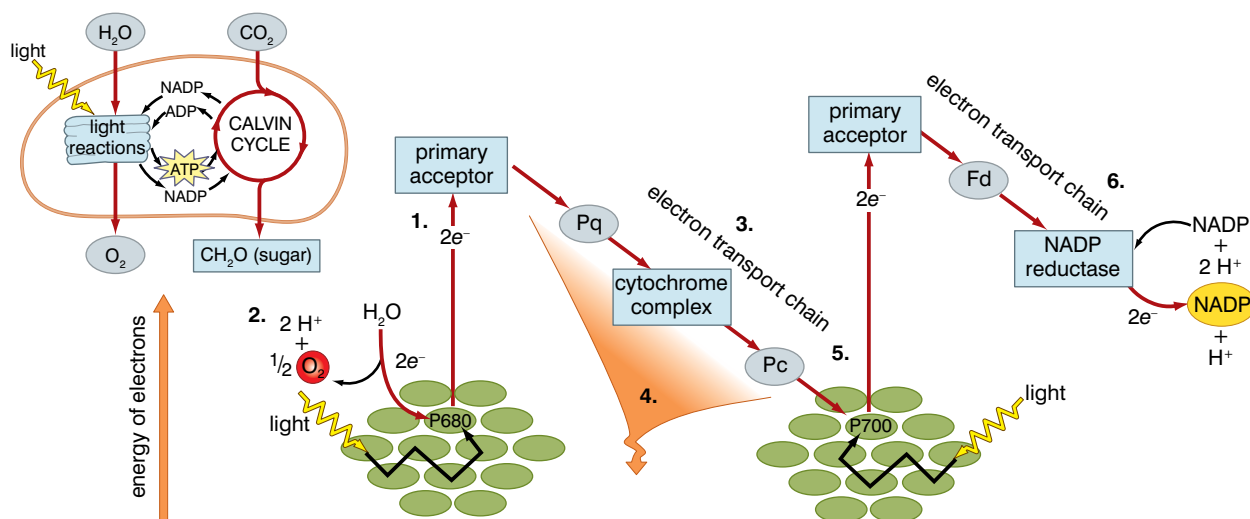


Figure 5.54

6. Figure 5.55 summarises the Krebs cycle.

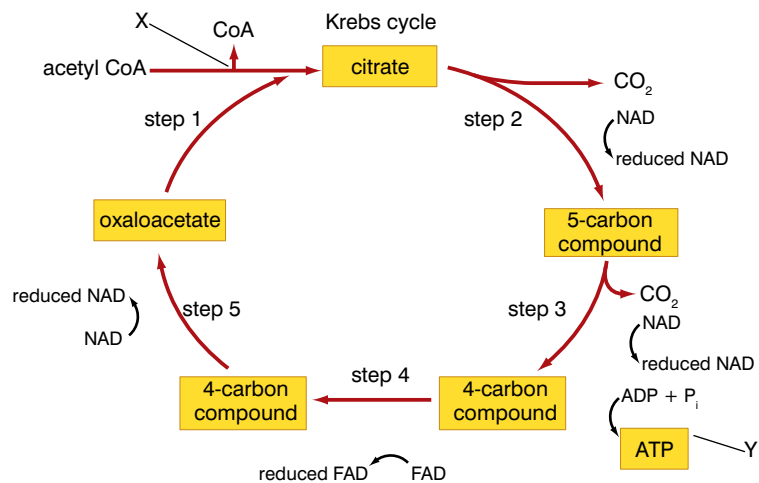


Figure 5.55

- a) (i) Name, and briefly describe, the processes labelled X and Y.  
 (ii) Describe one other occasion during aerobic respiration where the process labelled Y takes place.
  - b) In the absence of oxygen, the Krebs cycle cannot take place, even though its reactions do not use oxygen. Explain why.
  - c) Reduced NAD is also produced during glycolysis. Explain what becomes of this reduced NAD in animal cells under:
    - (i) aerobic conditions
    - (ii) anaerobic conditions
7. The graph in figure 5.56 shows the influence of temperature, carbon dioxide and light intensity on the rate of photosynthesis.

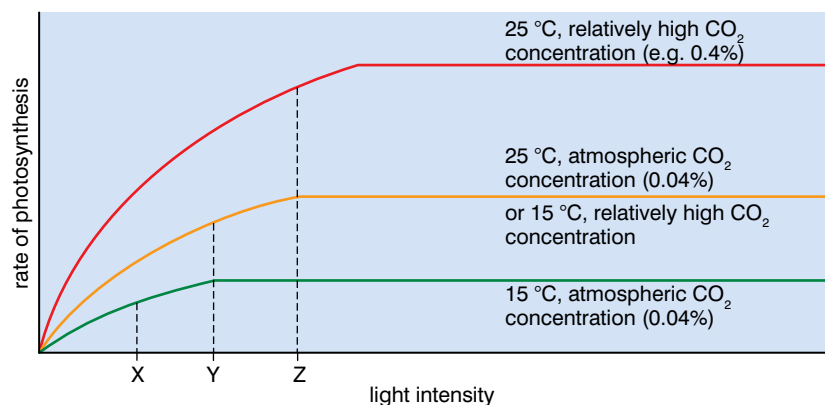


Figure 5.56

- a) In the regions labelled X, Y and Z, is light a limiting or a non-limiting factor? Give reasons for your answer.
- b) Describe and explain fully the difference between the three lines on the graph.

8. Figure 5.57 shows some of the reactions of the Calvin cycle.

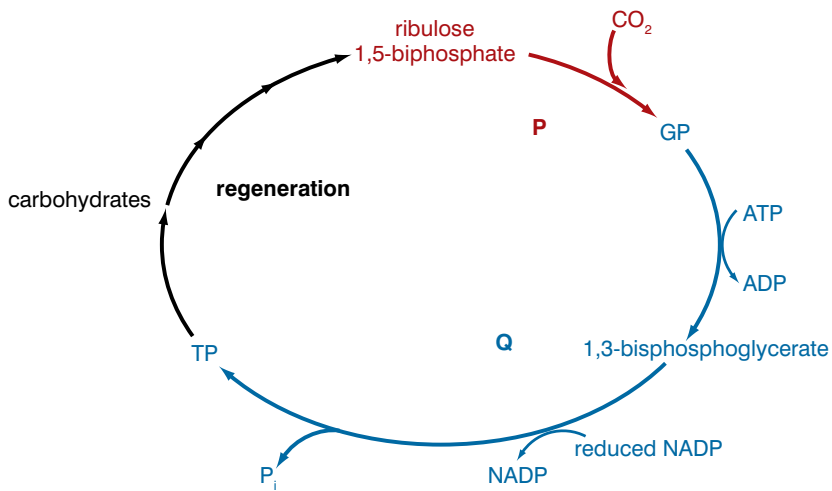


Figure 5.57

- Describe three possible fates of the TP formed in these reactions.
- Describe the processes occurring at P and at Q.
- The graph in figure 5.58 shows the changes in the levels of GP and RuBP in a chloroplast when the light source is removed.

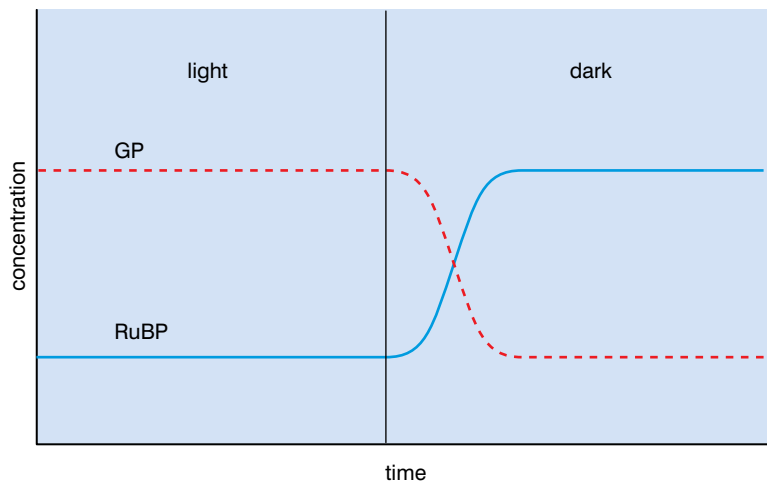
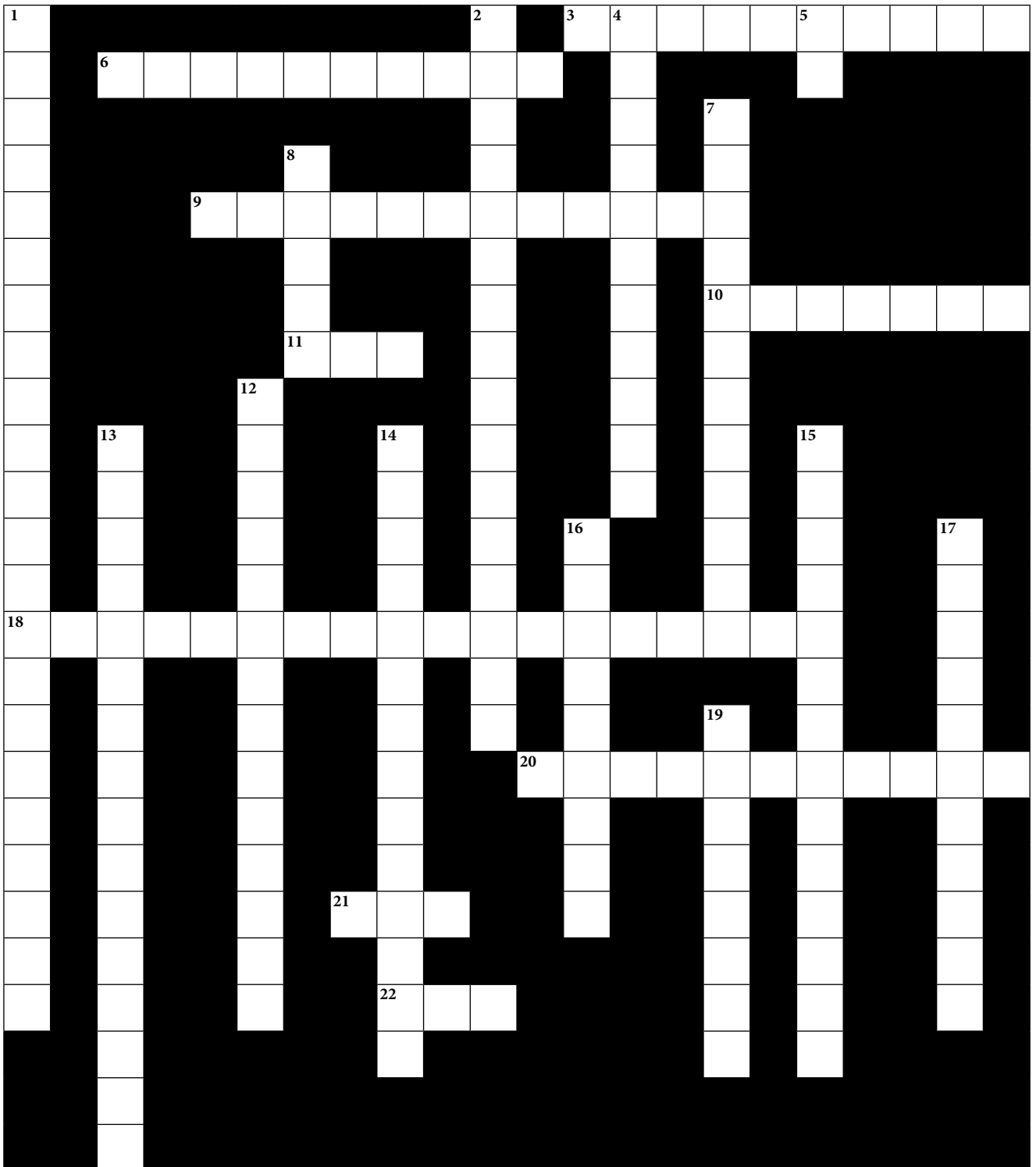


Figure 5.58

Use the graph to explain the changes in the levels of GP and RuBP when the light source is removed.

Copy the crossword puzzle below into your exercise book (or your teacher may give you a photocopy) and solve the numbered clues to complete it.



**Across**

3. Cycle of reactions that converts citrate to oxaloacetate (5, 5)
6. First stage of aerobic respiration (10)
9. Way in which ATP is produced by yeast when no oxygen is available (12)
10. Enzyme that catalyses the reaction between RuBP and carbon dioxide (7)
11. The main energy transfer molecule in a cell (3)
18. Smallest structure that can carry out all the reactions of the light-dependent stage of photosynthesis (14, 4)
20. Enzyme that catalyses the formation of ATP (3, 8)
21. Molecule that combines with  $P_i$  to produce ATP (3)
22. Nicotinamide adenine dinucleotide (3)

**Down**

1. Chain of molecules on cristae of mitochondria that moves electrons (8, 9, 5)
2. Reactions of photosynthesis that use ATP and reduced NADP to synthesise glucose (5, 11)
4. Process that releases energy from organic molecules (11)
5. Type of photosynthesis found in many tropical plants (2)
7. Stage of aerobic respiration in which pyruvate is converted to acetyl CoA (4, 8)
8. Stacks of thylakoids (5)
12. Process using light energy to drive the synthesis of carbohydrate (14)
13. Process in which RuBP combines with oxygen rather than carbon dioxide (16)
14. Reactions of photosynthesis that require light energy to produce ATP and reduced NADP (5, 9)
15. Type of phosphorylation in which a phosphate group is transferred to ADP from another substance (9, 5)
16. Type of phosphorylation that occurs at the end of the electron transport chain (9)
17. Cluster of photosynthetic pigments on a thylakoid membrane (11)
19. End-product of glycolysis (8)

# Index

- activation energy 79–81, 96  
active site 72, 73, 80–1  
active transport 126, 141  
ADP (Adenosine Di-Phosphate) 140–1, 143  
aerobic respiration 128, 143–51, 175, 176  
agriculture 26–7  
alcohol 54  
aldoses 48  
altimeter 22  
amino acids 56, 57, 58, 62, 67, 86, 94, 162, 170  
amylase 51, 52  
amylose 51–2, 67  
amylopectin 51–2, 67  
anaerobic respiration 152–5  
antibodies 56, 58  
antigens 48, 56, 58  
antiretroviral drugs 32  
apoenzyme 82  
apparatus 15–22  
astrobiologists 2  
atoms 39–40, 66  
    in carbohydrates 47, 51  
ATP (Adenosine Tri-Phosphate) 128, 140–1, 172  
    in lactate formation 153  
    via photophosphorylation 160  
    in plants 157–65  
    production in aerobic respiration 126, 143–51  
    synthase 141, 143, 148–9, 152, 175  
  
bacteria 113  
balances 16, 17  
behavioural psychology 26  
Benedict's test for reducing sugars 61, 68  
biological molecules *see* organic molecules  
biology 2–3, 25  
    and agriculture 26–7  
    and the environment 28  
    and HIV/AIDS 30–4  
    and medicine 27  
    relevance in Ethiopia 29  
biomedical research 2  
biotechnology 28  
Biuret test for protein 61, 68  
bonds 39, 40  
  
Calvin cycle 162–5, 169, 170, 171, 172, 173, 175  
carbohydrates 47–53, 66  
    cellulose 48, 51, 52, 53  
    chitin 48  
    disaccharides 50–1, 166  
    glycogen 52  
    metabolic pathway of 155  
    monosaccharides 48–50, 66  
    peptidoglycan 48  
    in plasma membranes 48  
    polysaccharides 51, 67  
    starch 47, 51–2, 61, 67  
    synthesis in light-dependent reactions 162–3  
carboxyl group 54, 57  
catalase 88  
catalysts 73, 79–81, 96  
cause and effect 8–9  
cell fractionation 131, 136  
cell membrane *see* plasma membrane  
cell processes 45  
cell theory, development of 102–5, 134  
cell wall 123, 130, 135  
cells 2, 20, 43, 60, 104  
    animal 123, 134, 152  
    different sizes, consequences of 108–9  
    eukaryotic 111–14, 130, 134  
    plant and osmosis 112, 124, 135  
    prokaryotic 111–14, 134  
    red blood and osmosis 124  
    size of and measuring 105–7, 134  
cellulose 48, 51, 52, 53  
centrifuge 20, 131  
chemical elements 38–40, 66  
chitin 48  
chlorophyll 157–60, 165  
chloroplasts 45, 130, 135, 157, 162, 170, 171, 175–6  
cholesterol 119  
chromosomes 57, 60  
coenzymes 82, 144, 146–7  
cofactor 82–3  
collagen 58, 59  
compounds 39–40, 66  
  
concentration gradient 120, 121, 122, 126  
condensation reaction 51, 53, 55, 57, 66, 67  
contraception 27  
culturing 18  
cytochromes 148, 159  
cytoplasm 112, 124, 128, 144, 145  
  
data logger 22  
decarboxylation 146  
dehydrogenation 146  
diffusion 119–22  
dipeptide 57  
disaccharides 50–1, 66  
dissection 17  
DNA (deoxyriboNucleic Acid) 41, 57, 58, 59–60, 68  
Dutrochet, Rene 104  
  
electron transport and chemiosmosis 144–5, 147–8, 152, 159, 175  
elements *see* chemical elements  
emulsion test for lipids 62, 68  
endoplasmic reticulum 112, 129  
endosymbiont theory 113  
endocytosis 126  
energy 79, 128  
environment 28  
enzymes 18, 42, 52, 57, 58, 96, 130  
    ATP synthase 141, 143, 148–9, 152, 175  
    as catalysts 73, 79–83, 96  
    cofactors, need for 82–3  
    concentration of substrate molecules, effect of 87–8  
    lipase 52, 72, 74  
    measuring the rate of an enzyme-controlled reaction 88–91  
    molecules 58, 72–3, 87, 88–9, 92  
    naming and classification of 74–6  
    other factors affecting activity 92–4  
    pH, effect of 86–7, 97  
    properties of 73–4  
  
substrates 72, 73, 80–1, 87, 92–4, 96, 97  
temperature, effect of 73–4, 85–6, 97, 163  
turnover rate 81, 85  
uses of 76–7  
    *see also* coenzymes  
ester bonds 55  
esters 54, 67  
exocytosis 127, 129  
experiments  
    accuracy in 9–10  
    reliability 10  
    report-writing 11–13  
    validity 11  
    *see also* scientific method  
  
FAD (Flavine Adenine Dinucleotide) 144, 145, 147, 148, 149, 152, 175  
fatty acids 40, 54–5, 67, 119  
fermentation products 152–4, 175  
Fleming, Alexander 37  
flow meter 22  
fluid mosaic model 117–19, 135  
fructose 49, 50, 61, 72, 146  
functional group 48  
  
global warming 26–7  
globular proteins 59, 72, 73  
glucose 49, 50, 53, 54, 61, 72, 141, 152, 153  
    in aerobic respiration 144–9  
glycerol 54, 55, 67  
glycogen 47, 48, 51, 53, 67  
glycolysis 144–6, 152, 175  
glycoproteins 48, 119, 135  
glycosidic bonds 51, 52, 53, 67  
Golgi apparatus 129, 130, 135  
GPS receiver 22  
HAART (highly active antiretroviral therapy) 32  
haemoglobin 58, 67  
herd immunity 31  
HIV/AIDS 30–4  
Hooke, Robert 103, 116  
hormones 58  
Human Genome Project 3



- hydrocarbon chains 54–5  
hydrogen bonds 40–1, 53, 58  
hydrogen ions 141, 143, 144, 145, 158  
hydrolysis reactions 44, 51, 66, 72, 141  
hypothesis 4–6, 12
- ice 42, 66  
immune system 30, 32, 32, 48, 56  
*see also* HIV/AIDS  
induced-fit model 80–1, 97  
inhibitors 92–4, 97  
inorganic molecules  
chemical elements 38–40  
water 40–5  
iodine and starch 18, 52, 61  
isomers 48
- ketoses 49  
Krebs cycle 144, 145, 146, 147, 152, 171, 175
- lactate formation during  
exercise 153  
lactose 50, 61  
Leewenhock, Anton van 103  
light-dependent reactions *see* photosynthesis  
light energy 42, 157–66  
limiting factors, law of 164, 165–6  
link reaction 144, 145, 146, 152, 175  
lipase 52, 72, 74  
lipids 54–6, 166  
emulsion test for 62, 68  
metabolic pathway of 155  
phospholipids 56  
triglycerides 54–5  
waxes 54
- lock and key model 80, 96  
lysosomes 129, 130, 135
- maltose 50, 61, 66  
medicine 27  
Mendel, Gregor 3  
metabolic pathways 93–4, 155  
microbiologists 3  
microfibrils 53  
micropropagation 18  
microscopes 19–20, 103, 107  
mineral ions 82–3  
mitochondria 128, 135, 144, 146, 147, 170  
molecules 39–40, 66, 67, 135, 141  
amino acid 56, 57, 58, 62, 67, 86, 94, 162, 170  
ATP in plants 157–65
- biochemical tests for 60–2  
carbohydrate *see* carbohydrates  
cellulose in plant cell walls 53  
and energy 79–81, 85, 141  
enzyme 58, 72–3, 87, 88–9, 92  
inorganic 38–45  
lipid 54–6, 155, 166  
macromolecules 51  
organic *see* organic molecules  
phosphorylated 140  
in photosystems 158–60  
polymer 51  
protein *see* protein  
reduced 144  
respiration, use in 143, 145, 146  
in starch 47, 51–2, 61, 67  
water 40, 43, 44, 50, 51, 72
- monomers 51  
monosaccharides 48–50, 66  
monounsaturated fatty acids 55  
macromolecules 51, 56  
monosaccharide 48–50, 66  
protein 56
- NAD (Nicotinamide Adenine Dinucleotide) 144, 145, 146, 147, 148, 152, 175  
NADP 158, 159, 165  
Newton, Isaac 3  
non-reducing sugars, Benedict's test for 61, 68  
nucleic acids 59–60, 67  
nucleotides 59, 67, 140  
nucleus 128, 129, 135
- organelles in animal cells 112, 128–35  
Golgi apparatus 129, 130, 135  
lysosomes 129, 130, 135  
mitochondria 45, 128, 135, 144, 146, 147, 170  
nucleus 128, 129, 135  
ribosomes 129, 135
- organelles in plant cells 130–1, 135, 170  
organic molecules 47–62, 66  
biological tests for 60–2  
carbohydrates 47–53, 66  
coenzymes 82, 144–7  
lipids 54–6  
nucleic acids 59–60  
proteins 56–9  
osmosis 122–7, 130  
oxidation 144
- oxidative phosphorylation 145, 152
- paleobiology 3  
Pasteur, Louis 4, 7–8  
penicillin 37  
peptide bonds 57  
peptidoglycan 48  
peroxisomes 170  
Petri dishes 18  
pH 22, 73–4, 85, 86–7, 97  
phospholipids 54, 56, 67  
phospholipid bilayers 56, 67, 116, 117, 118, 119  
photolysis 159  
photophosphorylation 143, 160  
photorespiration 169–71, 175  
photosynthesis 44, 45, 66, 130–1, 135, 141, 175  
ATP in plants 157–65  
C3 photosynthesis 169–71, 175  
C4 photosynthesis 171–2, 173, 175, 176  
CAM photosynthesis 173, 176  
in cacti 172–3, 175  
factors affecting the rate of 163–6  
light dependent reactions of 162–3, 175  
synthesis of carbohydrate 162–3
- photosynthetic unit 160  
photosystems 157–60  
pitfall traps 21–2  
plant cells 44–62, 112  
plants  
ATP molecule 157  
cell wall 123, 130, 135  
chlorophyll 147–60, 165  
chloroplasts 45, 130, 135, 157, 162, 170, 171, 175–6  
photosystems 157–60  
and water 44  
*see also* photosynthesis
- plasma membranes 56, 58, 127, 135  
active transport 126, 141  
appearance of 116–17  
and carbohydrates 48  
Davson-Danielli model 117–18, 135  
endocytosis 126  
exocytosis 127  
facilitated diffusion 121–2  
fluid mosaic model 117–19, 135  
osmosis 122–7, 130  
proteins in 117, 118–19
- simple diffusion 119, 120–1  
temperature, effect of 127  
polymers 51, 56, 57, 67  
polypeptides 57–8, 67  
polysaccharides 51, 67  
polyunsaturated fatty acids 55, 67  
protease 52  
proteins 51, 56–9, 67, 72, 73, 74, 129, 135  
Biuret test for 61, 68  
in diffusion 121–2  
metabolic pathway of 155  
in the plasma membrane 117, 118–19  
protein pumps 126  
proton pumps 148, 149, 159  
protons *see* hydrogen ions  
pyruvate 144–5, 146, 152, 171, 172, 175
- quadrats 20–1
- receptors 118  
Redi, Francesco 6–7  
redox reaction 144  
reducing sugars  
Benedict's test for 61, 68  
respiration 45, 47, 53  
aerobic 128, 143–51, 175, 176  
anaerobic 152–5  
respirometers 149–51  
ribosomes 129, 135  
ribulose biphosphate (RuBP) 162, 169, 171, 176  
RNA (RiboNucleic Acid) 59–60, 68, 73, 129  
Rubisco 162, 169, 170, 171, 175
- saturated fatty acids 55, 67  
Schleiden, Matthias 104, 134  
Schwann, Theodor 104, 134  
science 3–4  
scientific method 4–8  
*see also* experiments  
scientific models 117  
serine 170  
sphingolipids 54  
spontaneous generation 4, 6–8  
standard 10, 11  
starch 47, 51–2, 67  
iodine test for 61  
STDs (sexually transmitted diseases) 31  
substrate level phosphorylation 143  
sucrase 72  
sucrose 50, 72

surface-area-to-volume ratio  
108–9, 134

surface tension 43, 66

syringes 16

temperature 77, 85–6, 90–1,  
97  
and concentration gradi-  
ent 121  
control 42–3  
enzymes, effect on 73–4,  
85–6, 97, 163  
photosynthesis, effect on  
163, 164–5  
plasma membrane, effect  
on permeability of 127

thylakoides 131, 157, 171

tools see apparatus

triglycerides 54–5, 67

turgidity 124

ubiquinone 148

vacuole 130, 135

vaporisation 42–3

variables 8–9, 11, 90

Virchow, Rudolf 104, 134

water 40–4, 66  
molecules 43, 50, 51, 72  
osmosis 122–7, 130  
photolysis 159  
as a reactant 44–5, 66

water potential 122–5

wavelengths 158

waxes 54

yeast 59, 76, 154



