



Physics

Student Textbook Grade 11

Authors: Jim Newall
Susan Gardner
Graham Bone

Advisers: Tilahun Tesfaye Deressu (PhD)
Endeshaw Bekele Buli

Evaluators: Yosef Mihiret
Gebremeskel Gebreegziabher
Yusuf Mohamed



**Federal Democratic Republic of Ethiopia
Ministry of Education**



Acknowledgments

The development, printing and distribution of this student textbook has been funded through the General Education Quality Improvement Project (GEQIP), which aims to improve the quality of education for Grades 1–12 students in government schools throughout Ethiopia.

The Federal Democratic Republic of Ethiopia received funding for GEQIP through credit/financing from the International Development Associations (IDA), the Fast Track Initiative Catalytic Fund (FTI CF) and other development partners – Finland, Italian Development Cooperation, the Netherlands and UK aid from the Department for International Development (DFID).

The Ministry of Education wishes to thank the many individuals, groups and other bodies involved – directly and indirectly – in publishing the textbook and accompanying teacher guide.

The publisher would like to thank the following for their kind permission to reproduce their photographs:

(Key: b-bottom; c-centre; l-left; r-right; t-top)

Alamy Images: Andrew Paterson 156, Andrew Southon 135, Anthony Collins 93, GB 50, Hemis 180t, imagebroker 80, Jack Sullivan 121, Jeff Morgan Sport 139, Karin Smeds / Gorilla Photo Agency Ltd 3b, NASA 2t, Peter Arnold 130l, Pixoi Ltd 105, Sharkawi Che Din 177b, Simon Hadley 4, Speedpix 57, Superstock 154; **apexnewspix.com:** 3t; **Authentic models:** 149cl; **Corbis:** Kim Ludbrook 52, Mark Weiss 79, Pierre Vauthey / SYGMA 82, Steve Chenn 88; **Getty Images:** AFP 177t; **NASA:** 60, 136; **Pitsco Inc:** 106bl; **Science Photo Library Ltd:** Chris Sattlberger 176, Hermann Eisenbeiss 171, Volker Steger 2b

Cover images: Front: **Alamy Images:** Andrew Southon l; **Corbis:** Kim Ludbrook tr; **NASA:** br

All other images © Pearson Education

Every effort has been made to trace the copyright holders and we apologise in advance for any unintentional omissions. We would be pleased to insert the appropriate acknowledgement in any subsequent edition of this publication.

© Federal Democratic Republic of Ethiopia, Ministry of Education

First edition, 2002 (E.C.)

ISBN: 978-99944-2-020-9

Developed, Printed and distributed for the Federal Democratic Republic of Ethiopia, Ministry of Education by:

Pearson Education Limited

Edinburgh Gate

Harlow

Essex CM20 2JE

England

In collaboration with

Shama Books

P.O. Box 15

Addis Ababa

Ethiopia

All rights reserved; no part of this publication may be reproduced, stored in a retrieval system, or transmitted in any form or by any means, electronic, mechanical, photocopying, recording, or otherwise without the prior written permission of the copyright owner or a licence permitting restricted copying in Ethiopia by the Federal Democratic Republic of Ethiopia, Federal Negarit Gazeta, *Proclamation No. 410/2004 Copyright and Neighboring Rights Protection Proclamation, 10th year, No. 55, Addis Ababa, 19 July 2004.*

Disclaimer

Every effort has been made to trace the copyright owners of material used in this document. We apologise in advance for any unintentional omissions. We would be pleased to insert the appropriate acknowledgement in any future edition

Printed in Malaysia

Contents

Unit 1 Measurement and practical work	1
1.1 Science of measurement	2
1.2 Errors in measurement	9
1.3 Precision, accuracy and significance	12
1.4 Report writing	17
Unit 2 Vector quantities	22
2.1 Types of vector	22
2.2 Resolution of vectors	26
2.3 Vector addition and subtraction	28
2.4 Multiplication of vectors	33
Unit 3 Kinematics	38
3.1 Motion in a straight line	39
3.2 Motion in a plane	51
Unit 4 Dynamics	66
4.1 The force concept	67
4.2 Basic laws of dynamics	69
4.3 Law of conservation of linear momentum and its applications	75
4.4 Elastic and inelastic collisions in one and two dimensions	82
4.5 Centre of mass	85
4.6 Momentum conservation in a variable mass system	90
4.7 Dynamics of uniform circular motion	92
Unit 5 Work, energy and power	98
5.1 Work as a scalar product	99
5.2 Work done by a constant and variable force	101
5.3 Kinetic energy and the work-energy theorem	103
5.4 Potential energy	107

5.5	Conservation of energy	111
5.6	Conservative and dissipative forces	114
5.7	Power	116
Unit 6 Rotational motion		118
6.1	Rotation about a fixed axis	119
6.2	Torque and angular acceleration	120
6.3	Rotational kinetic energy and rotational inertia	124
6.4	Rotational dynamics of a rigid body	129
6.5	Parallel axis theorem	133
6.6	Angular momentum and angular impulse	135
6.7	Conservation of angular momentum	138
6.8	Centre of mass of a rigid body (circular ring, disc, rod and sphere)	140
Unit 7 Equilibrium		143
7.1	Equilibrium of a particle	144
7.2	Moment or torque of a force	146
7.3	Conditions of equilibrium	150
7.4	Couples	155
Unit 8 Properties of bulk matter		158
8.1	Elastic behaviour	159
8.2	Fluid statics	166
8.3	Fluid dynamics	175
8.4	Heat, temperature and thermal expansion	184
Index		200

Measurement and practical work

Unit 1

Contents

Section	Learning competencies
1.1 Science of measurement (page 2)	<ul style="list-style-type: none">• Explain the importance of measurement.• Identify and use appropriate units for data that will be collected.• Describe what is meant by the term significant figures and how it is related to precision.• Identify rules concerning the number of significant figures that a numeral has.• Define the term scientific method.• State the steps of scientific methods.• State the uncertainty in a single measurement of a quantity.• Identify the orders of magnitude that will be appropriate and the uncertainty that may be present in the measurement of data.
1.2 Errors in measurement (page 9)	<ul style="list-style-type: none">• Distinguish between random error and systematic error.• Describe sources of errors.• Identify types of errors.• Distinguish between random uncertainties and systematic errors.
1.3 Precision, accuracy and significance (page 12)	<ul style="list-style-type: none">• Distinguish between precision and accuracy.• State what is meant by the degree of precision of a measuring instrument.• Use scientific calculators efficiently.
1.4 Report writing (page 17)	<ul style="list-style-type: none">• Describe the procedures of report writing.• Use terminology and reporting styles appropriately and successfully to communicate information and understanding.• Present information in tabular, graphical, written and diagrammatic form.• Report concisely on experimental procedures and results.

One of the most important developments in the history of science was the scientific method, the procedure scientists use to acquire knowledge in any field of science.

Science is all about observing and experimenting. We need a framework to add relevance to observations and experiments.

Experiments may vary in size and expense, including using huge particle accelerators, making observations using space telescopes, testing simple circuits, or even just bouncing a ball! In order to be considered scientific, they must follow a key set of principles and be presented in a suitable manner. This section looks at how experiments should be represented and how the data should be analysed before drawing conclusions.



Figure 1.1 The Hubble space telescope

1.1 Science of measurement

By the end of this section you should be able to:

- Explain the importance of measurement.
- Identify and use appropriate units for data that will be collected.
- Describe what is meant by the term significant figures and how it is related to precision.
- Identify rules concerning the number of significant figures that a numeral has.
- Define the term scientific method.
- State the steps of scientific methods.
- State the uncertainty in a single measurement of a quantity.
- Identify the orders of magnitude that will be appropriate and the uncertainty that may be present in the measurement of data.

The scientific method

The scientific method is exceptionally important to the process of science. It ensures a rigorous, evidence-based structure where only ideas that have been carefully tested are accepted as scientific theory.

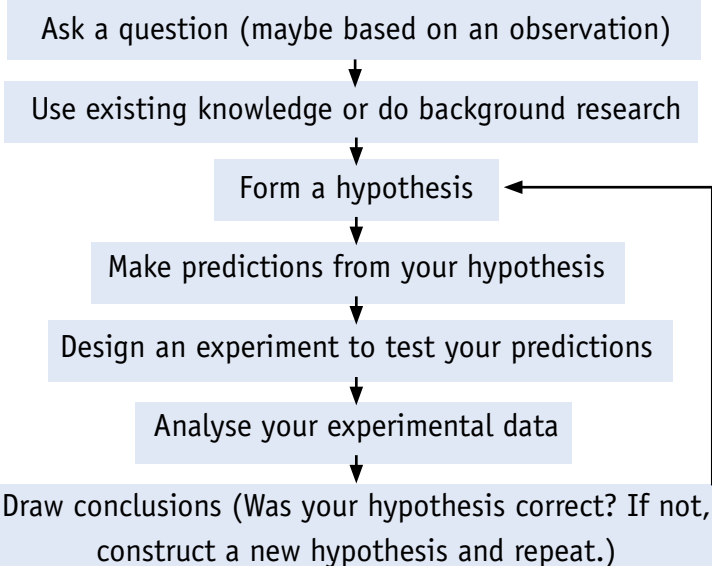

Figure 1.2 The scientific method



Figure 1.3 This scientist is researching ways of making energy-efficient lighting.

Your hypothesis will have to be tested by others before it becomes an accepted scientific theory. This process of peer review is very important and prevents scientists making up data.

The process of science begins with a question. For example: Why is the sky blue? Why does the Sun shine? Scientists are curious about the world around them; it is this curiosity that is the spark of the process.

When you have a question, scientists may have already looked into it and devised an explanation. So the first step is to complete some preliminary research into the existing theories. These theories may provide answers to your question. It is quite probable most of the questions you encounter in your physics course already have answers. However, there are still some big unanswered questions in physics. They are waiting for someone like you to answer them! Are there any questions that science cannot answer?

Using your existing knowledge or information collected via research, the next step is to form a **hypothesis**.

A hypothesis is just an idea that might provide an answer to your question. A scientific hypothesis is based on scientific knowledge, not just made up!

For example: *Why does the Sun shine?*

You might form two hypotheses:

- Nuclear fusion reactions in the Sun release heat and light.
- There is a large lamp in the centre of the Sun powered by electricity.

The first is clearly a more scientific hypothesis using some thoroughly tested existing ideas. That is not to say you shouldn't be creative in making a hypothesis but you should include some scientific reasoning behind your ideas.

It is important to note your hypothesis might be incorrect, and this is what makes science special. An investigation must be carried out to test the ideas before you either rule out an idea or accept it.

Why does the Sun shine?

Once you have a hypothesis, you should use it to form a series of predictions that can be tested through **experiment**. These may range from 'easy to test' to 'hugely complex' predictions. You then design an experiment to test your predictions.

Discussion activity

Some simple questions lead to massively complex experiments costing billions of dollars. One of these is the ATLAS project in Switzerland. This costs billions of dollars; do you think it is right to spend such a large amount of money on scientific experiments?



Figure 1.4 Scientists investigating renewable energy

Activity 1.1: Using the scientific method

Look around your classroom or outside. Make three observations, and using your existing scientific knowledge, form a hypothesis for each of them. Discuss these with a partner.



Figure 1.5 We all know that the Sun shines. But why?

KEY WORDS

hypothesis a proposed explanation for an observation
experiment a test under known conditions to investigate the truth of a hypothesis

KEY WORDS

analyse *examine in detail to discover the meaning of a set of results*

conclusions *the overall result or outcome of an experiment. The hypothesis being tested may be supported by the results or may be proven incorrect*

significant figures *the number of digits used in a measurement, regardless of the location of the decimal point*

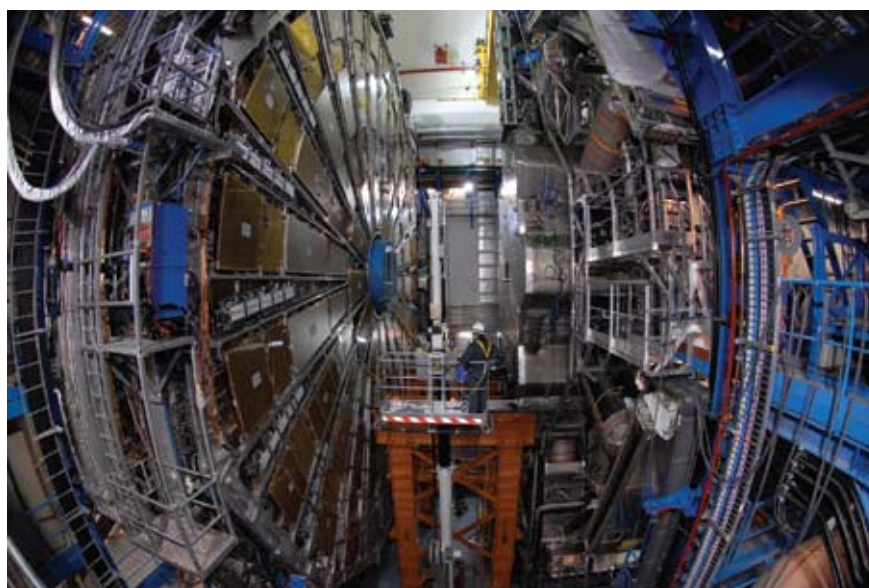

Figure 1.6 *The ATLAS detector in Switzerland*

It is important that your experiment is clearly planned. This will enable others to test your experiment and check your ideas (more detail on this can be found in Section 1.4).

Once you have carefully conducted your experiment, you will need to **analyse** your results and draw **conclusions**. At this stage you need to decide if your results support your prediction. If they do, then perhaps your hypothesis was correct. This will need to be confirmed by several other scientists before it becomes accepted as scientific fact.

If your results do not support your prediction, then perhaps your hypothesis was wrong. There is nothing wrong with that, you just go back and form a different hypothesis. This process continues and it may take years to come up with a correct hypothesis!

Activity 1.2: Choosing the right unit

In a group, discuss what units you would use when measuring each of the following:

- length of a football pitch, width of this book, diameter of a small seed, width of a finger nail.
- area of a page in this book, area of the floor in your classroom, area of a football pitch.
- volume of this book, volume of your classroom, volume of a bottle, volume of a soccer ball.

Making measurements

As part of your experiment you will have to make measurements and collect data. This process is very important and needs to be conducted carefully.

Choosing units

When you are planning your experiment, you need to choose units that are appropriate to the size of the quantity you are measuring. For example, you would measure the length of a finger in centimetres.

Explain why you have chosen the units.

Significant figures

All digits in a number that are not zero are called **significant figures**. For example, the number 523 has three significant figures and the number 0.008 has one significant figure. The zeroes in 0.008 are not significant figures but they are important as they tell you how big or small the number is.

When a number is given in standard form, the number of digits tells you how many significant figures there are. For example, 0.008 in standard form is 8×10^3 – it's now much more obvious that the number has one significant figure.

For any measurement you take, the number of significant figures (s.f.) must be consistent with the instrument precision. For example, if you are measuring length with a 1 m ruler that has mm on it, then all readings should be expressed to the nearest mm. For example:

0.6 m ✗
 0.64 m ✗
 0.643 m ✓

If your reading is exactly on an increment this still applies!

0.5 m ✗
 0.50 m ✗
 0.500 m ✓

You must be consistent with your use of significant figures in your results tables. If your data is to two significant figures, so should be your average. For example:

Reading one: 62 Reading two: 61 Average: ??

The average here should be 62, not 61.5 as this is going from two to three significant figures.

If you then go on to calculate something using your data, you must express your answer to the lowest number of significant figures in your data. For example, if you are calculating average speed you might have the following:

$$\text{Average speed} = \frac{\text{distance travelled}}{\text{time taken}}$$

$$\text{Distance travelled} = 4.345 \text{ m}$$

$$\text{Time taken} = 1.2 \text{ s}$$

The distance travelled is to four significant figures but the time taken is only to two. This means your answer should only be to two significant figures:

$$\text{Average speed} = \frac{\text{distance travelled}}{\text{time taken}}$$

$$\text{Average speed} = \frac{4.345 \text{ m}}{1.2 \text{ s}}$$

$$\text{Average speed} = 3.62083333\dots$$

$$\text{Average speed} = 3.6 \text{ m/s (to 2 significant figures)}$$

Zeros between the significant figures and the decimal point are also significant as well as demonstrating the magnitude of the quantity. 'Trailing zeroes' (e.g. the zeroes in 3.20000) are also considered significant.

Table 1.1 Prefixes and their symbols

Prefix	Power of 10	Symbol
giga-	10^9	G
mega-	10^6	M
kilo-	10^3	k
hecto-	10^2	h
deca-	10	da
deci-	10^{-1}	d
centi-	10^{-2}	c
milli-	10^{-3}	m
micro-	10^{-6}	μ
nano-	10^{-9}	n

Discussion activity

Is 100 V to one, two or three significant figures? The answer is it could be any of those! If your reading is to a whole number you may need to specify its number of significant figures.

KEY WORDS

uncertainty *the amount of doubt in a measurement*

Activity 1.3: Measuring bounce height of a ball

Collect a ball and ruler. In small groups drop the ball from various heights (around ten different heights) and record how high it bounces. Notice how difficult it is to determine the bounce height to anything less than the nearest cm.

If you were using the same ruler to measure the width of a piece of paper, you might also get 16.0 cm; however, your uncertainty would be much less than 1.0 cm! This is because the piece of paper is not moving, so measuring is easier than with the bouncing ball. Perhaps you would write $16.0 \text{ cm} \pm 0.1 \text{ cm}$.

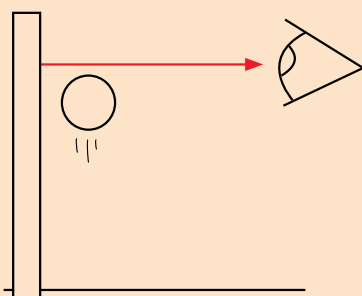

Figure 1.7 Measuring bounce height of a ball

Uncertainties

Every measurement you take will have an **uncertainty** associated with it. It does not mean it is wrong, it is just a measure of your confidence in your measurement. If you were measuring the height of a friend, you might write:

1.80 m

Does this mean exactly 1.8 m? Does it mean 1.8000 m? When you write 1.80 m you mean your friend's height is between 1.805 m and 1.795 m. You could write this as:

$1.80 \text{ m} \pm 0.005 \text{ m}$

The 0.005 m is the uncertainty in your reading. You have measured the height to the nearest 5 mm. You should try to keep this uncertainty as small as possible (more on this in Section 1.3).

The uncertainty in every measurement will be related to the nature of the task and the precision of the instrument you are using.

For example, measuring the height of a ball bouncing is very difficult. You might measure the height using a ruler with mm on it as 16.0 cm, but what is the uncertainty?

$16.0 \text{ cm} \pm 0.1 \text{ cm}$ → Even though the ruler may measure to mm it is very hard to measure the height to the nearest mm as this is too small.

$16.0 \text{ cm} \pm 0.5 \text{ cm}$ → This is possible, if you ensure to measure the bounce height carefully; by getting down to eye level and doing a test drop it might be fair to say you can measure the height to the nearest $\frac{1}{2}$ cm.

$16.0 \text{ cm} \pm 1.0 \text{ cm}$ → This is a realistic uncertainty for this experiment.

$16.0 \text{ cm} \pm 2.0 \text{ cm}$ → This might be a little unrealistic, but is also acceptable, since determining the bounce height by eye is quite difficult.

$16.0 \text{ cm} \pm 5.0 \text{ cm}$ → Hopefully you have designed the experiment to enable you to measure to more than the nearest 5 cm!

Which uncertainty you use is a judgement you will have to make depending on the results.

Discussion activity

Can you think of some other examples of measurements you might take using a ruler and what the uncertainty might be in each case?

Percentage uncertainties

You may need to calculate the percentage uncertainty in one of your readings. This is just the uncertainty of the reading expressed as a percentage. If you measured the current through a bulb, you might express your measurement as:

$$4.32 \text{ A} \pm 0.05 \text{ A}$$

So the percentage uncertainty would be:

$$\frac{0.05}{4.32} \times 100 = 1.157407\dots\%$$

So you would write $4.32 \text{ A} \pm 1.2\%$.

As a rule of thumb, percentage uncertainties should be to two significant figures.

You should always aim to keep your percentage error under 10%, although this may not always be possible.

Whenever possible you should measure **multiple values** instead of just one. For example, the time for 20 swings of a pendulum rather than just one, or several thicknesses of card rather than just one. This has the effect of reducing the percentage uncertainty as shown below:

One piece of card	Ten pieces of card
$1.03 \pm 0.05 \text{ mm} \rightarrow 4.9\%$	$10.41 \pm 0.05 \text{ mm} \rightarrow 0.48\%$

Notice the uncertainty is still the same but the percentages are very different.

Calculations

You need to determine the uncertainty in a quantity you have calculated. For example, when calculating resistance from values of p.d. (potential difference) and current:

$$p.d. = 4.32 \text{ V} \pm 1.157407\dots\% \quad \text{Current} = 2.3 \text{ A} \pm 4.534641\dots\%$$

$$\text{Resistance} = \frac{p.d.}{\text{current}}$$

$$\text{Resistance} = \frac{4.32 \text{ V}}{2.3 \text{ A}}$$

$$\text{Resistance} = 1.9 \Omega \text{ (2 s.f., as the value of the current is to 2 s.f.)}$$

To find the percentage uncertainty in the resistance you just add the percentage uncertainties of the p.d. and current. This gives $5.692047\dots\%$, and so you would write: $1.9 \Omega \pm 5.7\%$. Do not round up until the end!

You could express the resistance ($1.9 \Omega \pm 5.7\%$) as $1.9 \pm 0.1 \Omega$. This is because 5.7% of 1.9 is $0.108\dots\Omega$ and also as the resistance reading is to 1/10 of an ohm, you would write 0.1Ω not 0.11Ω .

This is same if you are multiplying quantities together. For example, calculating distance travelled using

$$\text{distance travelled} = \text{average speed} \times \text{time taken.}$$

Activity 1.4: Percentage uncertainty for the bouncing ball

Using the data collected on the bounce height of the ball, calculate the percentage uncertainty in each case. What do you notice about the smaller readings? The larger your reading, the smaller the percentage uncertainty. So small distances have a greater percentage uncertainty than large distances, if measured with the same instrument.

KEY WORDS

multiple values *several readings of the same measurement*

Activity 1.5: Uncertainty in the dimensions of a book

Using a ruler, measure the dimensions of a book in centimetres. Write down the dimensions, the uncertainty for each, and express this as a percentage.

Use your readings to calculate the volume of the book. Calculate the percentage uncertainty in the volume and express this in cm^3 .

Average speed: $\pm 4.1\dots\%$

Time taken: $\pm 3.4\dots\%$

Therefore: distance travelled: $\pm 7.5\%$

Be careful if there is a square in the equation. For example, area of a circle = πr^2 . If r has a percentage uncertainty of $2.312\dots\%$, then the area will have a percentage uncertainty of 4.6% as the equation is effectively: area = $\pi \times r \times r$. So the error in r must be counted twice ($2.312\dots\% + 2.312\dots\% = 4.624\dots\%$ so 4.6% to 2 s.f.).

Summary

In this section you have learnt that:

- The scientific method includes: observing, researching, hypothesising, predicting, experimenting, analysing and concluding.
- Measurements must always be recorded to an appropriate number of significant figures (this depends on the equipment you are using).
- All measurements have an uncertainty associated with them. This is effectively a quantification of the amount of doubt in a measurement.
- To determine the uncertainty of a calculated value, you add the percentage uncertainties of the quantities used to perform the calculation.

Review questions

1. Describe each part of the scientific method. Explain why it is important to follow this structure when conducting a scientific investigation.
2. How many significant figures do the following numbers have:
a) 258 b) 0.2 c) 12 000 d) 0.084
3. How can you reduce the percentage uncertainty in measurements that you make?
4. Nishan and Melesse have measured the voltage across a resistor to be 5.26 V and the current flowing through it to be 0.41 A . They work out the resistance.
Nishan says that the resistance is 12.8Ω . Melesse disagrees and says that the resistance is 13Ω .
Who is correct? Explain your answer.
5. A bulb is connected as part of a circuit. The following data is collected:
Electric current: $3.2 \text{ A} \pm 0.1 \text{ A}$
Potential difference: $12.3 \text{ V} \pm 0.1 \text{ V}$

Use this data and the equation

$$\text{Resistance} = \frac{\text{potential difference}}{\text{electric current}}$$

to determine the resistance. Express the uncertainty in your answer.

1.2 Errors in measurement

By the end of this section you should be able to:

- Distinguish between random error and systematic error.
- Describe sources of errors.
- Identify types of errors.
- Distinguish between random uncertainties and systematic errors.

What are errors?

An experimental error (or just referred to as an error) is not the same as a mistake. An example of a mistake would be to measure the height of a desk when asked to measure the height of a chair. It is just plain wrong!

The measurements you take as part of your investigations will contain experimental errors, but hopefully no mistakes. Errors occur in every scientific investigation; they affect your measurements, making them different from the **accepted value** (sometimes called **true value**) of the item being measured. There are several different types of experimental error.

Accepted or true value

This is the actual value of the physical property you are measuring. It is the value you would get if it were possible to make the measurement with no experimental errors.

Random error

Random errors are errors with no pattern or bias. They cause measurements to vary in an unpredictable manner. Importantly, they cause your measurements to be sometimes above the accepted value, sometimes below the accepted value.

For example, if you were measuring the acceleration due to gravity, random errors will cause your readings to vary both above and below the accepted value.

Accepted value for acceleration due to gravity = 9.80665 m/s^2 (to 6 s.f.)

Recorded values (m/s^2)						
9.81	9.78	9.65	9.87	9.80	9.86	9.83

KEY WORD

accepted/true value *the actual value of the property being measured, made without any experimental errors*

random errors *unpredictable errors that have no pattern or bias and which may be above or below the true value*

Activity 1.6: Testing random error with a ruler

Make yourself a ruler by cutting a strip of card 15.0 cm long. Use a ruler to carefully mark on the centimetre divisions.

Use your ruler to make several different length measurements of items in your classroom. You must resist the temptation to record your readings to the nearest mm. A suitable uncertainty will be to the nearest 0.5 cm.

Repeat the experiment using a real ruler. You will find about half of your readings were too high, the other half too low. This kind of random error happens with all measurements. Even those taken with the real ruler will either be 0.5 mm too high or 0.5 mm too low.

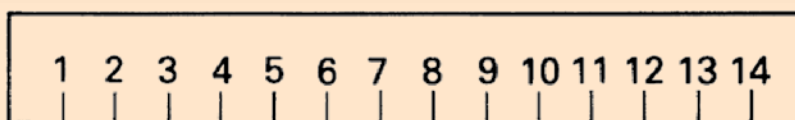

Figure 1.8 Home-made ruler

Another example of a random error could be encountered when completing investigations into heat. The surrounding temperature will vary depending on the time of day and general weather conditions. If you are conducting an experiment over a number of days, this will produce random errors in your measurements.

To reduce the effect of random errors, wherever possible you should take several readings and average them. The more repeats you take, the lower the impact of random errors.

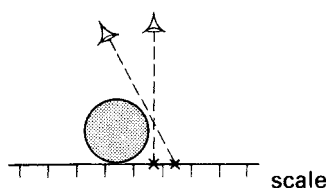

Figure 1.9 Viewing from directly above avoids a parallax error.

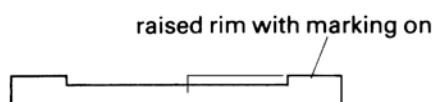

Figure 1.10 How does this arrangement avoid parallax errors?

Parallax errors with scales

The use of a ruler for length is not without its problems at times. If you wanted to measure the diameter of a table-tennis ball, how might you do it?

When the object and the scale lie at different distances from you, it is essential to view them from directly above if you are to avoid what we call parallax errors (Figure 1.9).

A clock in a public place has to be read from many different angles. A neat way of avoiding parallax errors in that case is shown in Figure 1.10.

With an instrument designed to be read by a single experimenter, you must take care to position your head correctly. Two ways of achieving the same thing with a current meter are shown in Figure 1.11.

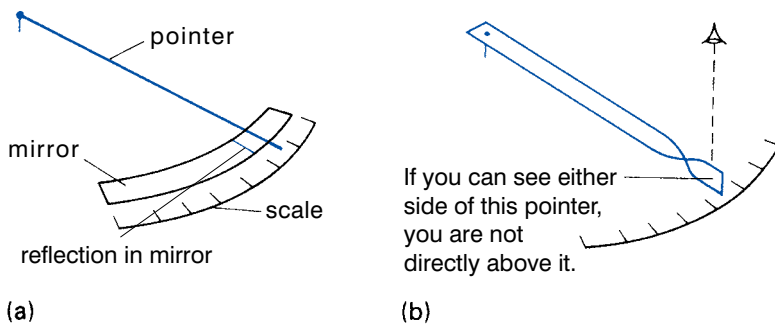

Figure 1.11 Two ways of preventing parallax errors. (a) You know you are looking straight down on the pointer when it is hiding its own reflection in the mirror. (b) A flat pointer is twisted so it is upright at the tip.

Returning to the question of the diameter of the table-tennis ball, two rectangular wooden blocks would help (Figure 1.12).

Discussion activity

A little thought is still needed for the best possible result. What if the blocks are not quite parallel? The doubt can be removed by measuring both ends of the gap as shown in the drawing; if the two lengths differ slightly, their average should be taken.

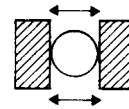

Figure 1.12 Measuring using wooden blocks

Figure 1.13 shows some calipers, which can do the same job as the ruler and the two blocks. They may be made of steel, and the part drawn shaded will slide along the main part. It must fit snugly, so that the shaded prong A is always at right angles to the arm B.

The arrow engraved on the sliding part indicates the diameter of the ball, on the millimetre scale. If the ball is removed and the jaws are closed, that arrow should then lie on the zero of the scale.

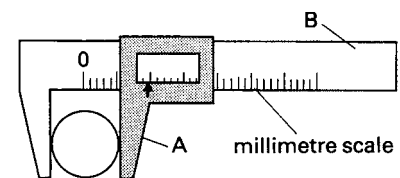

Figure 1.13 Measuring using the Vernier calipers

Systematic errors

A **systematic error** is a type of error that shows a bias or a trend. It makes your readings too high every time, or too low every time. Taking repeated readings will not help account for this type of error.

A simple example might be an ammeter that always reads 0.4 A too low. So if your reading was 6.8 A, the true value for the current would be 7.2 A. More complex examples include ignoring the effect of friction in Newton's second law experiments, or not measuring to the centre of mass of a simple pendulum.

The problem with systematic errors is that they can be quite hard to spot! When you have found the source you then either redesign the experiment or account for the error mathematically.

KEY WORD

systematic errors errors caused by a bias in measurement and which show a bias or trend

This is quite easy to do. Take for example a voltmeter where each reading is 0.2 V too large. To find the corrected value you need to subtract 0.2 V from each of your readings.

Recorded value (v)	Corrected value (v)
2.8	2.6
6.4	6.2
10.8	10.6
15.4	15.2
20.7	20.5

Zero errors

Zero errors are special examples of a systematic error. They are caused by an instrument giving a non-zero reading for a true zero value. For example, the ammeter mentioned above is a type of zero error. When the current is 0 A it would read -0.4 A.

KEY WORDS

zero errors errors caused by equipment that has not been correctly zeroed

Summary

In this section you have learnt that:

- Experimental errors cause readings to be different from their true value.
- Random errors cause readings to be above and below the true value.
- Systematic errors cause a bias in your readings (they are all either too high or too low).
- Parallax errors can cause your readings to be less accurate because of the position of your eye.
- A zero error is a type of systematic error caused by equipment not being zeroed properly.

Review questions

1. Explain the meaning of the term error.
2. Describe different types of errors, give examples, and explain how the effect of these errors might be reduced.

1.3 Precision, accuracy and significance

By the end of this section you should be able to:

- Distinguish between precision and accuracy.
- State what is meant by the degree of precision of a measuring instrument.
- Use scientific calculators efficiently.

What does 'accurate' mean?

Accuracy means how close a reading is to the true value. The more accurate a reading, the closer it is to the true value.

Again using the acceleration due to gravity as an example:

Accepted value for acceleration due to gravity = 9.80665 m/s^2
(to 6 s.f.)

If you took three readings you might get:

9.76 9.87 9.82

The most accurate reading is the third one; it is closest to the true value.

In order to obtain more accurate measurements you must ensure you have minimised random errors, taken into account systematic errors and conducted the experiment as carefully as you can.

Precision and significance

The **precision** of your reading is a measure of the degree of 'exactness' of your value; this is sometimes related to the number of significant figures in the reading. The more precise a reading is, the smaller the uncertainty. A series of precise measurements will have very little variation; they will all be very similar.

For example, dealing with lengths:

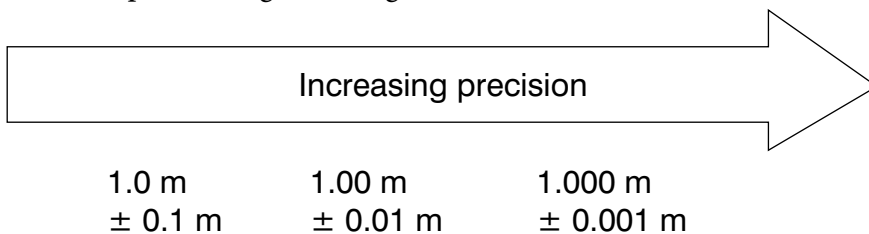

The **significance** of your reading is indicated by the number of significant figures you can express your data to. This was discussed in Section 1.1

It is very important not to overstate the significance of your readings. If your ruler measures to mm, then your readings should be to mm; it would not be right to give a length of 1.2756 m.

This is particularly true when calculating values. Take, for example, calculating the resistance of a light bulb:

$$\text{Resistance} = \frac{\text{potential difference}}{\text{electric current}}$$

Potential difference = $10.0 \text{ V} \pm 0.1 \text{ V}$ (so a 1.0% uncertainty)

Current = $3.0 \text{ A} \pm 0.1 \text{ A}$ (so a 3.3% uncertainty)

KEY WORDS

accuracy *the closeness of a measurement to its true value*

precision *the quality of being exact and the degree to which repeated measurements under the same conditions give the same value*

significance *the number of significant figures used in a reading, which should be appropriate to the precision of the measuring instrument*

This shows a series of imprecise measurements, they are all quite spread out. In addition, the readings are inaccurate as they are not clustered around the true value. This is what you want to try to avoid!

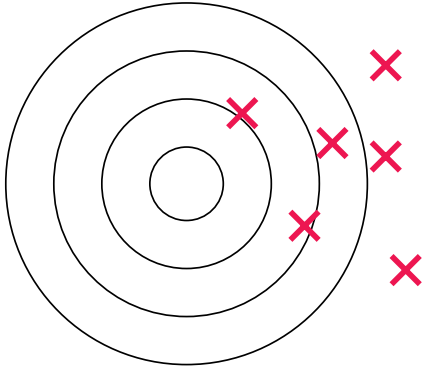

Figure 1.14 Imprecise and inaccurate

This shows a series of precise measurements; there is very little variation in the readings. However, they are also inaccurate as they are quite far from the true value (centre). A systematic error may give these kinds of results.

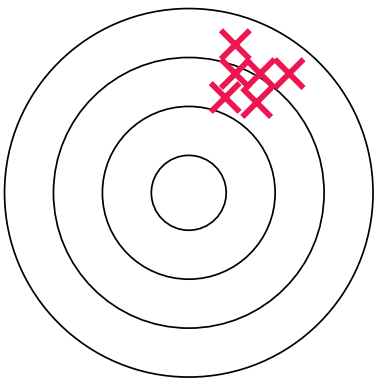

Figure 1.15 Precise but inaccurate

Put this into your calculator and you would get:

$$\text{Resistance} = \frac{\text{potential difference}}{\text{electric current}}$$

$$\text{Resistance} = \frac{10.0 \text{ V}}{3.0 \text{ A}}$$

$$\text{Resistance} = 3.33333333 \Omega$$

As previously discussed you would answer 3.3Ω to two significant figures, but why did the calculator give 3.3333333?

The answer is to do with how calculators treat values. When you enter 10.0 V, you mean $10.0 \text{ V} \pm 0.1 \text{ V}$ but the calculator takes the value to be exactly 10. That is 10.0000000000000000.... The same sort of thing is true for your current reading.

To express the resistance as 3.33333333Ω would be wrong. It implies the reading is more precise than it actually is.

Accurate and precise

Accuracy and precision are often confused. A common analogy to help overcome this involves using a target. The centre of the target represents the true value and each shot represents a measurement.

Here the measurements are imprecise as there is quite a large spread of readings, but at the same time they are accurate (they are all gathered around the true value). A large random error may cause this.

This is what we are aiming for! High precision, little spread from readings and all close to the true value.

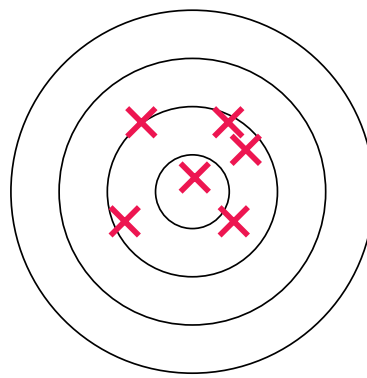

Figure 1.16 Accurate but imprecise

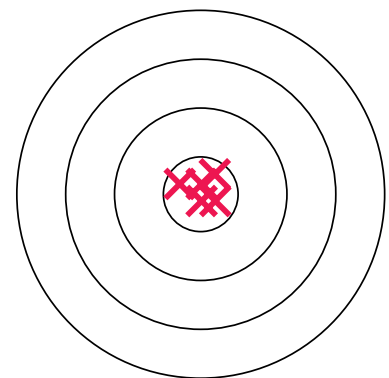

Figure 1.17 Accurate and precise

Instrument precision

The precision of an instrument is given by the smallest scale division on the instrument. A normal ruler may have a precision of 1 mm but a screw gauge micrometer has a precision of 0.01 mm.

When you are taking single readings, the precision of the piece of equipment you are using usually determines the uncertainty. For example, if you are using an ammeter with a precision of 0.01 A, then your readings might be:

$$0.32 \pm 0.01 \text{ A or } 2.61 \pm 0.01 \text{ A}$$

An exception to this rule would be if the nature of the task meant that there are other random errors that produce an uncertainty greater than the precision of the equipment.

For example, the bouncing ball experiment described earlier, or measuring the time of a pendulum swinging. A stopwatch may have a precision of ± 0.001 s but your reaction time is much greater. As a result it might be better to express the uncertainty as ± 0.1 s.

However, when you are taking multiple readings, for example recording p.d. with a voltmeter which has a precision of ± 0.01 V, you may obtain the following:

$$4.32 \text{ V} \quad 4.36 \text{ V} \quad 4.27 \text{ V}$$

The average would be 4.32 V (to 3 s.f., as the other readings). To express this average as 4.32 ± 0.01 V would not be right as you can tell by looking at your results the variation is more than ± 0.01 V.

In this case you would use half the range as your uncertainty. In the example above, the range from 4.27 V to 4.36 V is 0.09 V, so therefore half this range is 0.05 V. The average reading would be written as 4.32 ± 0.05 V. If you have no variation in your repeats, then you would use the precision of the instrument as the uncertainty.

Solving physics problems

When you are solving physics problems you need to make sure that you use the correct units. For example, one length may be given in feet and another in metres. You need to convert the length in feet to metres using a **conversion factor**. When you do the calculation, check that the units are correct using dimensional analysis.

If there are any intermediate stages in the calculation, keep all of the figures on your calculator screen for later stages in the calculation. You should only round your calculation to the appropriate number of significant figures at the end of the calculation.

Always check your calculations, because it is easy to make mistakes. Check that you are using the conversion factor correctly by making sure that when the units cancel, you are left with the units that you think you should have.

Activity 1.7: Determining instrument precision for different instruments

Look at a range of different pieces of measuring equipment. Determine the instrument precision in each case.

Activity 1.8: Uncertainty in the swing of a pendulum

Using a piece of string and some plasticine, make a simple pendulum. Working in pairs, time how long it takes to complete one swing for various different lengths. Repeat this three times for each length.

Calculate the average time of one swing for each length, and determine the uncertainty in this reading.

Discussion activity

How could you reduce the percentage error in the timing of the pendulum experiment?

KEY WORDS

conversion factor *a numerical factor used to multiply or divide a quantity when converting from one system of units to another*

Remember that when you are talking about an order of magnitude for an answer, this is much less precise than saying that it is approximately equal to something. For example, saying that N is \sim (is about) 10^{25} implies that N is in the range 10^{24} to 10^{26} , but saying that $N \approx 10^{25}$ implies that N is in the range, say 9×10^{24} to 1.1×10^{25} . The latter answer is much more precise.

Worked example 1.1

Berihun walks 3000 feet in 10 minutes. What speed is he walking at? Give your answer in metres per second.

First you need to convert the distance to metres and the time into seconds.

Conversion factor for feet to metres = 1 metre/3.28 feet

Distance = 3000 feet \times 1 metre/3.28 feet

= 914.634 14 metres

Remember to keep all the digits from the conversion for the next stage in your calculation.

Time = 10 minutes = 10 \times 60 seconds = 600 seconds

Speed = distance \div time

= 914.634 14 metres \div 600 seconds = 1.524 390 2 m/s

The greatest number of significant figures is three in the conversion factor, so your answer should be given to three significant figures.

Speed = 1.52 m/s

Summary

In this section you have learnt that:

- Accuracy is a measure of how close a measurement is to the true value of the quality being measured.
- Precision is a measure of the degree of 'exactness' of your value.
- A series of precise measurements will have very little variation.
- The significance of a measurement is indicated by the number of significant figures in your value.
- The precision of an instrument is usually given by the smallest scale division on the instrument. More precise instruments have smaller scale divisions.

Review questions

1. Explain the terms accuracy and precision. Describe how they differ using examples of experiments that you might conduct.
2. Research the precision of a range of instruments in your classroom.
3. Dahnay is 167 cm tall. Abeba is 66 inches tall. Who is taller and by how much.

The conversion factor for inches to centimetres is 2.54 cm/1 inch.

4. a) What difference would it make to the answer in the worked example if you rounded the answer to the intermediate step to 3 significant figures?
b) What effect do you think rounding the answer to each step might have in a calculation with several intermediate steps?

1.4 Report writing

By the end of this section you should be able to:

- Describe the procedures of report writing.
- Use terminology and reporting styles appropriately and successfully to communicate information and understanding.
- Present information in tabular, graphical, written and diagrammatic form.
- Report concisely on experimental procedures and results.

Presenting information

Science is a collaborative process. As discussed in the first section, all ideas must be independently tested and verified. It is therefore important to ensure that when you write up reports or write up experiments, you do so carefully.

Your results should be recorded in a clear and organised manner. This will usually be in a tabular format. Your tables should include all your raw data, including repeated readings and, where appropriate, columns for processed data (averages, calculations of resistance, etc). It is up to you if you wish to include clearly incorrect readings in your table, or simply repeat the reading.

Column headings must be labelled with a quantity and unit. You should use the standard convention for this: Quantity (unit). For example: Time (s) or Mass (kg).

A sample table can be seen below:

Length (m)	Current (A)			
	1st Set	2nd Set	3rd Set	Average

KEY WORDS

framework *an outline structure that can be used as the basis for a report*

A framework for writing up reports

There are lots of different ways to write up scientific investigations. Your teacher may have some suggestions.

A sample 10-point **framework** can be seen here. You might not always include every section for every experiment you write up, but instead just focus on three or four of the sections.

1 Title (and date)**2 Aim**

- What theory are you going to test? Or what are you going to investigate, and why? Or what are you going to measure?

3 Theory

- Explain the theory behind your experiment, with all the equations set out and explained clearly.
- If you are going to plot a graph to find a quantity, explain how the graph will enable you to do this.
- You should then be able to refer back to/quote from this section in your method and in your analysis of results.

4 Diagram(s) of experimental arrangement(s)

- These should be BIG (don't be afraid to take up a full page), detailed and fully labelled, and showing how the experiment works.

5 Method

- Don't repeat information that is already in the diagram!
- Give a clear, detailed and step-by-step procedure (bullet-point list), including measurements to be taken, any repeats,

AND:

- Accuracy
- How did you ensure the accuracy of your measurements? (Any zero errors, was the experiment horizontal, etc.)
- How did you choose appropriate instruments to give readings to an appropriate precision? Mention the precision and range of key instruments used. For example, 1 m rule with a 1 mm scale, or a 0–10 A ammeter reading to 0.01 A.
- Did you do repeats? Were you looking from the correct angle when making measurements, etc?

6 Results

- Neatly set out ALL data/measurements recorded in a neat table, and averages (if applicable).
- Don't forget headings/explanations of each table, and don't forget the units either.

7 Analysis

- What does your data show?
- Draw large graphs (with suitable scales, so that points take up a least half of the paper) on graph paper, with titles, labelled axes (units), and best-fit (not necessarily straight) smooth lines drawn through the points.
- Describe what your graphs show.
- When you use information from your graph(s) explain what you are using – e.g. gradient, area, etc.

8 Error/uncertainty analysis

- Identify all possible sources of error in your measurements. Distinguish between random and systematic uncertainties.
- Quantify the uncertainty of these (e.g. using $\frac{1}{2}$ -range or instrument precision (see Section 1.3). Express the uncertainty as a percentage for important readings.
- Use these to estimate the uncertainty in your final results.

9 Conclusions

- This should refer back to the aim – i.e. can you answer the question implied by the aim?
- If measuring something, quote final value with experimental uncertainty. If there is an accepted value, comment on the difference between your value and the accepted value.
- Does your experimental data fit the theory within experimental uncertainty?

10 Evaluation

- How could you improve the experiment – how could you improve the reliability? Be specific and realistic – just saying 'be more careful' or 'use better equipment' is not enough.

Summary

In this section you have learnt that:

- Your experimental results should be recorded in a clear and organised manner.
- Experimental results are usually recorded in tabular form.
- You can use a 10-point framework to write up scientific investigations.

End of unit questions

1. Explain the importance of the scientific method.
2. Construct a glossary of all the key terms used in this unit.
3. Use the writing frame on pages 19–20 and complete all sections. Carry out a detailed investigation into one of the following:
 - a) How the height a ball is dropped from affects the height it bounces up to.
 - b) How the length of a piece of wire affects the electric current passing through it.
 - c) How the angle of slope affects the time taken for a ball to roll down the slope.
4. For the two activities in question 3 that you did not carry out, identify:
 - a) Possible sources of error.
 - b) The sizes of the uncertainties in the measurements you would take.
5. Makeda says that you should write down all the numbers on the calculator display when recording the final result of a calculation. Is Makeda correct? Explain your answer.

Contents	
Section	Learning competencies
2.1 Types of vector (page 22)	<ul style="list-style-type: none">• Demonstrate an understanding of the difference between scalars and vectors and give common examples.• Explain what a position vector is.• Use vector notation and arrow representation of a vector.• Specify the unit vector in the direction of a given vector.
2.2 Resolution of vectors (page 26)	<ul style="list-style-type: none">• Determine the magnitude and direction of the resolution of two or more vectors using Pythagoras's theorem and trigonometry.
2.3 Vector addition and subtraction (page 27)	<ul style="list-style-type: none">• Add vectors by graphical representation to determine a resultant.• Add/subtract two or more vectors by the vector addition rule.
2.4 Multiplication of vectors (page 33)	<ul style="list-style-type: none">• Use the geometric definition of the scalar product to calculate the scalar product of two given vectors.• Use the scalar product to determine projection of a vector onto another vector.• Test two given vectors for orthogonality.• Use the vector product to test for collinear vectors.• Explain the use of knowledge of vectors in understanding natural phenomena.

You have studied vectors in grade 9. An understanding of vectors is essential for an understanding of physics.

They help physicists and engineers to build amazing structures and to design spacecraft, and they also help you find your way home!

2.1 Types of vector

By the end of this section you should be able to:

- Demonstrate an understanding of the difference between scalars and vectors and give common examples.
- Explain what a position vector is.
- Use vector notation and arrow representation of a vector.
- Specify the unit vector in the direction of a given vector.

Introduction and recap of basic vectors

All physical quantities are either scalar or vector quantities:

- A vector quantity has both **magnitude** (size) and direction.
- A **scalar** quantity has magnitude only.

All vector quantities have a direction associated with them. For example, a displacement of 6 km to the West, or an acceleration of 9.81 m/s^2 down. Scalars are just a magnitude; for example, a mass of 70 kg or an energy of 600 J.

Table 2.1 Some examples of vector and scalar quantities

Vector quantities	Scalar quantities
Forces (including weight)	Distance
Displacement	Speed
Velocity	Mass
Acceleration	Energy
Momentum	Temperature

Representing vectors

All vector quantities must include a direction. For example, a displacement of 8 km would not be enough information. We must write 8 km South.

Vectors can be represented by arrows, the magnitude (size) of the vector is shown by the length of the arrow. The direction of the arrow represents the direction of the vector.

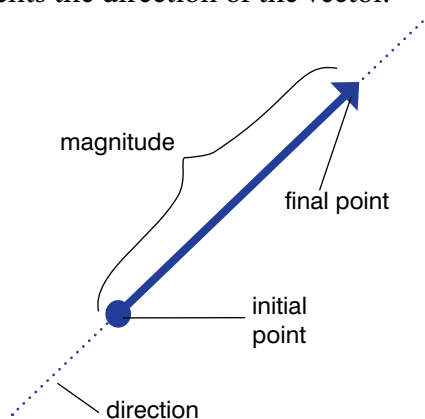

Figure 2.2 A vector has size (magnitude) and direction.

Representing vectors as arrows

Vectors are sometimes written in lowercase boldface, for example, **a** or **a**. If the vector represents a displacement from point A to point B, it can also be denoted as:



KEY WORDS

magnitude *the size of a value*

scalar *a quantity specified only by its magnitude*

Discussion activity

Which of the following do you think are scalars and which are vectors? Electric current, moment, time, potential difference, resistance, volume, air resistance and charge.

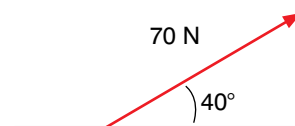

Figure 2.1 An arrow representing a force of 70 N at about 40° to the horizontal. Is this a vector or a scalar?

DID YOU KNOW?

In 1881 vectors appeared in a publication called *Vector Analysis* by the American J. W. Gibbs. They have been essential to maths and physics ever since!

Activity 2.1: Drawing vector diagrams

Draw four vector arrows for the following (you will need to use different scales):

- 140 km North
- 2.2 N left
- 9.81 m/s^2 down
- 87 m/s at an angle of 75° to the horizontal.

KEY WORDS

collinear vectors vectors that are parallel to each other and which act along the same line

coplanar vectors vectors that act in the same two-dimensional plane

position vector a vector that represents the position of an object in relation to another point

unit vector a vector with a length of one unit

Types of vector

There are several different types of vector to consider. These are outlined below.

Position vector

A **position vector** represents the position of an object in relation to another point.

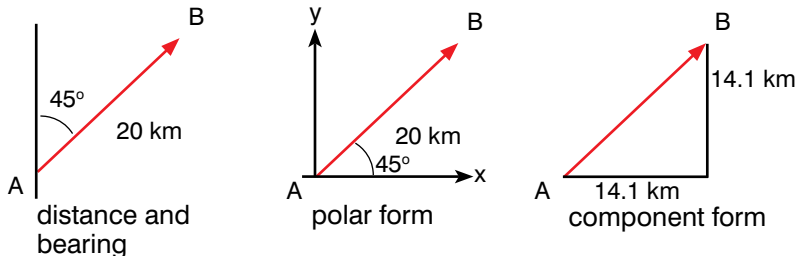

Figure 2.3 Position vectors

B is 20 km North East of A. Alternatively this could be written as B is 20 km from A on a bearing of 45°. Remember that bearings are specified as an angle going clockwise from north. The vector can be given in polar form. The angle is given from the positive x-axis, going anticlockwise. The angle can be in degrees or radians. The vector B from A is: $B = (20, 45^\circ)$

The vector can also be given in component form, where it is given in terms of the components in the x, y and z directions. The vector B is: $B = (14.1 \text{ km}, 14.1 \text{ km}, 0 \text{ km})$

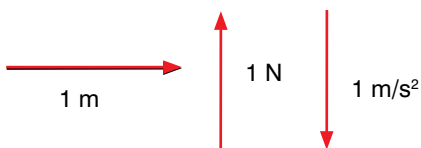

Figure 2.4 Unit vectors

Unit vector

A **unit vector** is a vector with a length equal to one unit. For example, Figure 2.4 contains three examples of unit vectors, one each for displacement, force and acceleration.

Unit vectors can also have direction. There are three unit vectors which are used to specify direction, as shown in Figure 2.5:

- unit vector **i** is 1 unit in the x-direction
- unit vector **j** is 1 unit in the y-direction
- unit vector **k** is 1 unit in the z-direction.

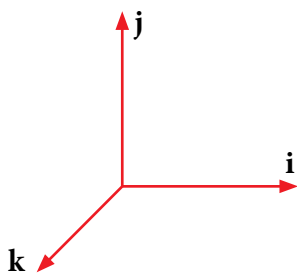

Figure 2.5 Unit vectors **i**, **j** and **k**

Collinear vector

Collinear vectors are vectors limited to only one dimension. Two vectors are said to be collinear if they are parallel to each other and act along the same line. They can be in the same direction or opposite directions.

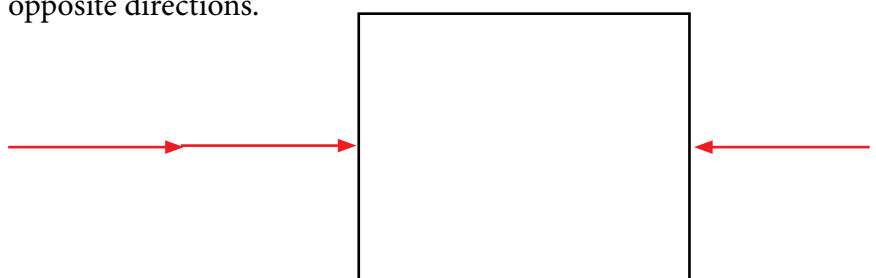

Figure 2.6 These three vectors are collinear

Coplanar vector

This refers to vectors in the same two-dimensional plane. This may include vectors at different angles to each other. For example, Figure 2.7 shows two displacement vectors when viewed from above.

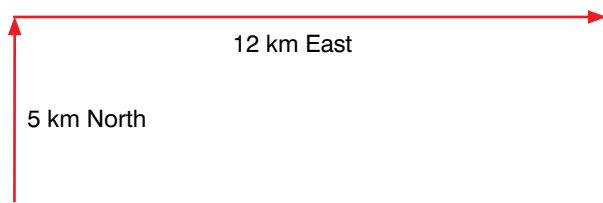

Figure 2.7 Coplanar displacement vectors

A more complex example might involve three forces acting on a cube.

A and B are both in the same plane (the xy plane) so they might be described as coplanar. C is in a different plane and so is not coplanar.

B and C are in the same plane (the xz plane) so they might be described as coplanar. A is in a different plane and so is not coplanar.

A and C are in the same plane (the yz plane) so they might be described as coplanar. B is in a different plane and so is not coplanar.

A, B and C cannot be considered to be coplanar with each other as they are in different planes.

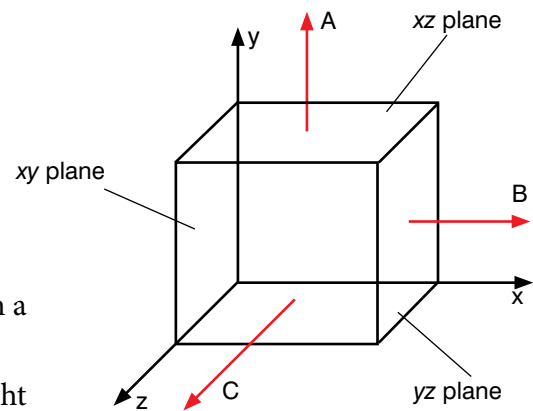

Figure 2.8 Three vector forces acting on a cube

Summary

In this section you have learnt that:

- A vector quantity has both magnitude (size) and direction.
- A scalar quantity has magnitude only.
- Vectors are often represented by arrows.
- Different types of vectors include position vectors, unit vectors, collinear vectors (along the same line) and coplanar vectors (in the same two-dimensional plane).

Review questions

1. Define the terms vector and scalar. Give five examples of each.
2. Explain the differences and similarities between position vectors, unit vectors, collinear vectors and coplanar vectors. Give examples for each.

KEY WORDS

component vectors *two or more vectors that, when combined, can be expressed as a single resultant vector*

resolving *splitting one vector into two parts that, when combined, have the same effect as the original vector*

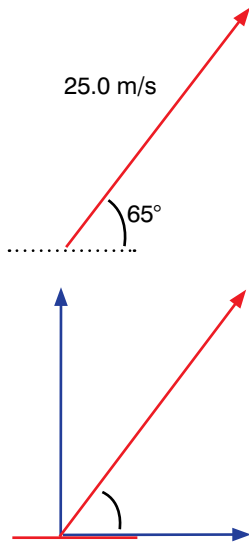

Figure 2.9 Component vectors of the main vector are shown in blue

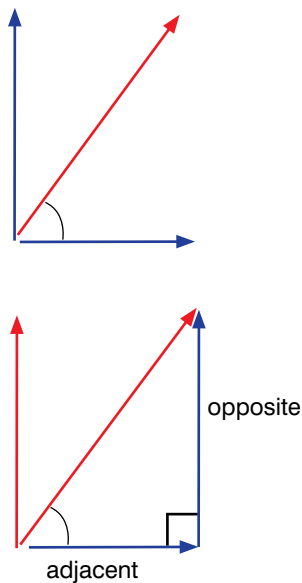

Figure 2.10 Component vectors as a right-angled triangle

2.2 Resolution of vectors

By the end of this section you should be able to:

- Determine the magnitude and direction of the resolution of two or more vectors using Pythagoras’s theorem and trigonometry.

What is resolution?

Resolving means splitting one vector into two **component vectors**. This may be a component in the *x* direction (horizontal) and another in the *y* direction (vertical). The two components have the same effect as the original vector when combined.

An example can be seen in Figure 2.9, the velocity of 25.0 m/s can be resolved into two component vectors that, when combined, have the same effect.

The component vectors can be made to form the sides of a right-angled triangle. They make up the opposite and adjacent sides of the triangle.

As we know the size of the hypotenuse (in this case 25.0 m/s) and the angle (in this case 65°), we can then use trigonometry to find their relative sizes.

Using trigonometry to resolve vectors

You will probably remember the following rules from your maths class:

$$\sin \theta = \frac{\text{opposite}}{\text{hypotenuse}}$$

$$\cos \theta = \frac{\text{adjacent}}{\text{hypotenuse}}$$

$$\tan \theta = \frac{\text{opposite}}{\text{adjacent}}$$

In the case of Figure 2.9:

- hypotenuse \times $\sin \theta$ = opposite
- 25.0 m/s \times $\sin 65$ = 22.7 m/s in the *y* direction
- hypotenuse \times $\cos \theta$ = adjacent
- 25.0 m/s \times $\cos 65$ = 10.6 m/s in the *x* direction

You can check your working by using Pythagoras’s theorem to recombine the vectors.

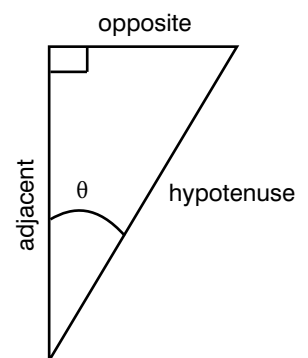

Figure 2.11 The basic rules of trigonometry

Pythagoras's theorem

For a right-angled triangle, Pythagoras's theorem states:

$$a^2 = b^2 + c^2$$

We can use this to work out the magnitude of two coplanar vectors.
We can use trigonometry to work out the direction of the two vectors.

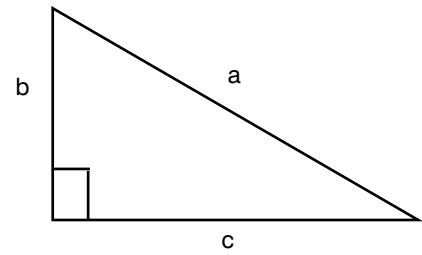

Figure 2.12 A right-angled triangle demonstrates Pythagoras's theorem

Worked example 2.1

What is the a) magnitude and b) direction of the two coplanar vectors in Figure 2.13?

a) $D^2 = 3^2 + 4^2 = 9 + 16 = 25$

$$D = \sqrt{25} = 5 \text{ m}$$

b) $\tan \theta = \text{opposite/adjacent} = 4/3 = 1.333 \dots$

$$\theta = \tan^{-1} 1.333 \dots = 53^\circ$$

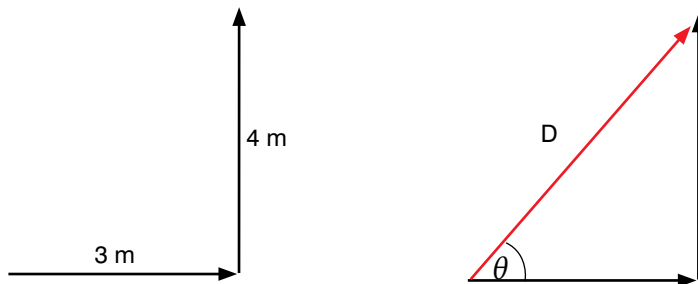

Figure 2.13 Two perpendicular coplanar vectors form a right-angled triangle.

Summary

In this section you have learnt that:

- Resolving means splitting a vector into two perpendicular components.
- The components have the same effect as the original vector.
- Trigonometry can be used to determine the magnitude of the components.
- Vectors can be added mathematically using Pythagoras's theorem and trigonometry.

Review questions

1. Explain what it means to resolve a vector.
2. Draw simple vector diagrams and resolve them into two components.
 - a) 60 N at an angle of 30° from the horizontal.
 - b) 45 m/s at an angle of 80° from the horizontal.
 - c) 1900 km at an angle of 40° from the vertical.

DID YOU KNOW?

Vectors are used in computer games to determine the movement of a character. Software will convert the commands from the games controller into a three-dimensional vector to describe how the character should move.

2.3 Vector addition and subtraction

By the end of this section you should be able to:

- Calculate vectors by graphical and mathematical methods.
- Appreciate the parallelogram rule and the triangle rule.
- Solve more complex examples of vectors.

Activity 2.2: Drawing scale diagrams

Draw a scale diagram to find the resultant displacement from the following:

- 12 km at an angle of 0° to the vertical
- 24 km at an angle of 90° to the vertical
- 6 km at an angle of 120° to the vertical
- 30 km at an angle of 210° to the vertical

Adding vectors

It is often necessary to add up vectors to find the resultant vector acting on a body. This may be the resultant velocity of an object, the resultant force acting on an object, or even the resultant displacement after several legs of a journey.

Vector diagrams

The first technique for vector addition involves carefully drawing diagrams. This can only be applied to collinear or coplanar vectors (this is because your diagrams will be two-dimensional only!).

There are three slightly different techniques that could be used.

Scale diagrams

Whenever you are drawing vector diagrams you should draw them to a scale of your own devising. Scale diagrams are very simple:

- Select a scale for your vectors.
- Draw them to scale, one after the other (in any order), lining them up head to tail ensuring the directions are correct.
- The resultant will then be the arrow drawn from the start of the first vector to the tip of the last.

For example:

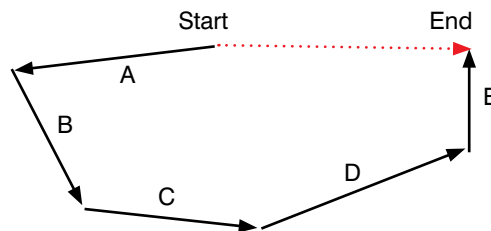

Figure 2.14 Scale diagram showing a resultant vector (the red arrow) for a series of coplanar vectors

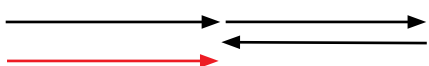

Figure 2.15 Adding three collinear vectors

It does not matter in which order you draw your vectors. Check them for yourself!

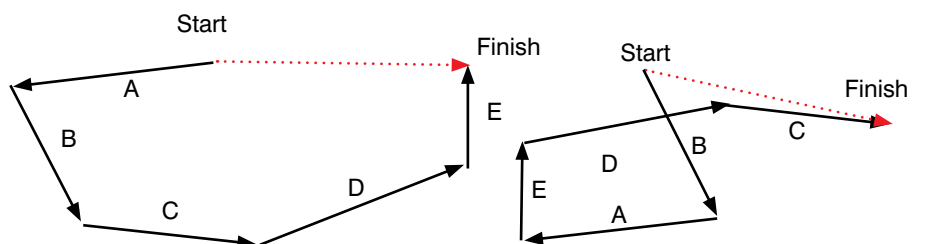

Figure 2.16 The resultant vector remains the same

If you end up where you started, then all the vectors cancel out and there is no resultant vector.

The fact that you can add vectors in any order and get the same resultant vector is called the **commutative law**.

Parallelogram rule

If you have two coplanar vectors, you could use the parallelogram rule. This involves drawing the two vectors with the same starting point. The two vectors must be drawn to a scale and are made to be the sides of the parallelogram. The resultant will be the diagonal of the parallelogram.



Figure 2.18 Two perpendicular coplanar vectors

If the vectors are perpendicular, the parallelogram will always be a rectangle.

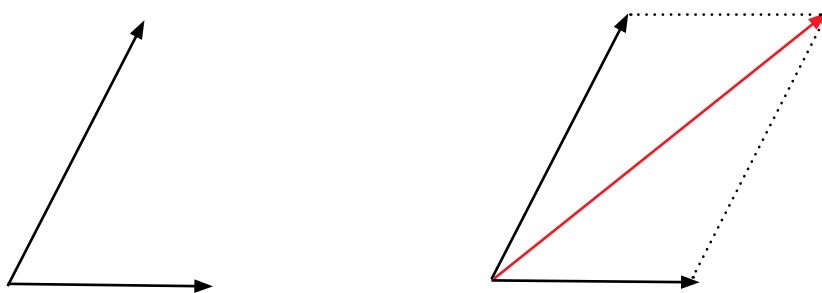

Figure 2.19 Two non-perpendicular coplanar vectors

If the vectors are still coplanar but not perpendicular, the parallelogram will not be a rectangle.

Triangle rule

This is a very similar technique, it involves drawing the two coplanar vectors but this time drawing them head to tail. The two vectors must again be drawn to a scale. The resultant will be the missing side from the triangle.

If the vectors are perpendicular, the triangle will be a right-angled triangle.



Figure 2.20 Two perpendicular coplanar vectors

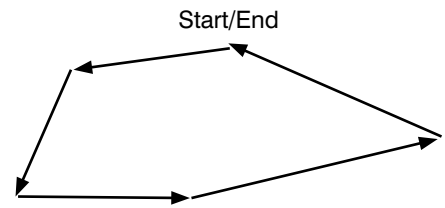

Figure 2.17 Scale diagram showing no resultant force

KEY WORDS

commutative law a process obeys the commutative law when it does not matter which order the quantities are in. For example, the addition of numbers obeys the commutative law.

Activity 2.3: Finding an unknown force

There are three forces acting on an object, A, B and C. This object is at equilibrium (there is no resultant force acting on it). Draw a scale diagram to find the magnitude and direction of the unknown force.

- Force A, 45 N at an angle of 0° to the horizontal
- Force B, 30 N at an angle of 300° to the vertical
- Force C, unknown

Discussion activity

If the triangle is a right-angled triangle, we could use trigonometry to determine the sides and angles mathematically. What if the triangle is not a right-angled triangle?

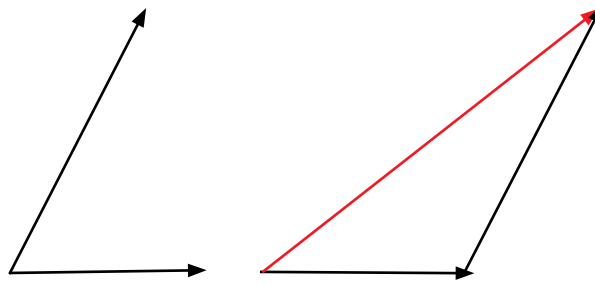

Figure 2.21 Two non-perpendicular coplanar vectors

If the vectors are still coplanar but not perpendicular the triangle will not be a right-angled triangle.

Activity 2.4: Determining resultant velocity

Use the parallelogram rule to determine the resultant velocity of the following two velocities:

- Velocity A, 30 m/s at an angle of 45° to the horizontal.
- Velocity B, 40 m/s at an angle of 80° to the horizontal.

Repeat, this time use the triangle rule.

Activity 2.5: Adding vectors

Vector A is 6 m/s along the horizontal and vector B is 9 m/s at 90° to the horizontal.

- Add vector B to vector A.
- Add vector A to vector B.

Does the order you add the vectors make any difference to the resultant?

Adding coplanar vectors mathematically

To add coplanar vectors we use more complex mathematics.

Since two perpendicular coplanar vectors form a right angled-triangle, they can be added using Pythagoras's theorem and trigonometry. Pythagoras's theorem determines the magnitude, and trigonometry can be used to determine the direction.

Component method

We can also express vectors as components in the x, y and z directions.

The resultant vector shown in Figure 2.13 can be expressed in component form as (3, 4), where the first number is the magnitude in the x-direction and the second number is the magnitude in the y-direction. The vector can also be given in the column form $\begin{bmatrix} 3 \\ 4 \end{bmatrix}$.

We can also add and subtract vectors in this form.

Activity 2.6: Adding forces

You are going to pull on a block of wood with two forces. You will find the resultant of the two forces, and then check your findings by adding the vectors.

- Find a suitable block of wood and three forcemeters (newtonmeters or spring balances). Place the block on a sheet of plain paper.
- Attach two of the forcemeters (A and B) to one end of the block as shown in Figure 2.22. Attach the third (C) to the opposite end.
- One person pulls on each forcemeter. A and B should be at an angle of 90° to each other. C is in the opposite direction. Pull the forcemeters so that their effects balance.
- On the paper, record the magnitudes and directions of the three forces.
- Now add forces A and B together using vector addition.

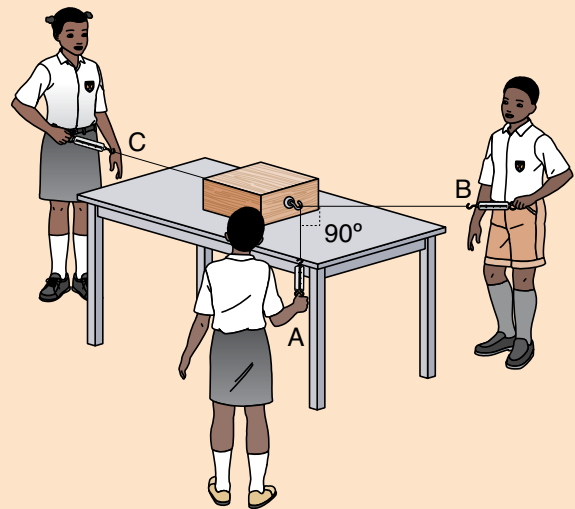

Figure 2.22 Testing vector addition of forces

- Because force C balances forces A and B, it must be equal and opposite to the resultant of A and B. Did you find this?
- Repeat the experiment with different forces at a different angle.

Worked example 2.2

Nishan and Melesse are trying to drag a box. Nishan is using a force of (15, 8, 6) N and Melesse is using a force of (12, 10, -6) N.

What is the resultant force on the box?

First draw a diagram to show the forces.

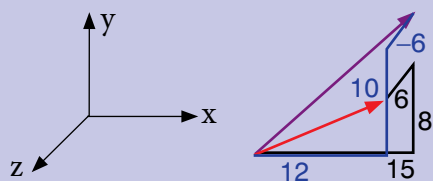

Figure 2.23 Forces acting on the box

Add the components of the forces together using:

$$F_A + F_B = (A_x + B_x, A_y + B_y, A_z + B_z)$$

$$F_A = (15, 8, 6) \text{ N}$$

$$F_B = (12, 10, -6) \text{ N}$$

$$\begin{aligned} \text{So } F_A + F_B &= (15 + 12, 8 + 10, 6 + -6) \text{ N} \\ &= (27, 18, 0) \text{ N} \end{aligned}$$

Worked example 2.3

We can also use the cosine rule and the sine rule to work out the magnitude and direction of the sum of two vectors.

Consider two vectors **a** (5 m along horizontal) and **b** (6 m at an angle of 60° above the horizontal).

First draw a diagram showing the vector addition.

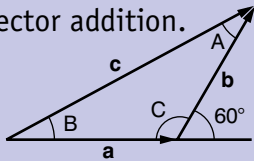

Figure 2.24

We can use the cosine rule to calculate the magnitude of the resultant using

$$c = \sqrt{a^2 + b^2 - 2ab \cos C}$$

where a and b are the magnitudes of the two vectors and c is the magnitudes of the resultant.

We can then use the sine rule to calculate the angle B of the resultant vector c

$$\sin B = (b \sin C)/c$$

From the diagram, we can see that angle C is $180^\circ - 60^\circ = 120^\circ$

Substituting the values in to the equation to find the magnitude of c :

$$c = \sqrt{5^2 + 6^2 - 2 \times 5 \times 6 \cos 120^\circ}$$

$$= \sqrt{25 + 36 - 2 \times 5 \times 6 \times -0.5}$$

$$= \sqrt{25 + 36 + 30}$$

$$= \sqrt{91}$$

$$= 9.54 \text{ m}$$

Substituting into the equation to find the angle

$$\sin B = (6 \times \sin 120^\circ)/9.54$$

$$= 6 \times 0.866/9.54$$

$$= 0.545$$

$$\text{so } B = \sin^{-1} 0.545 = 33.0^\circ$$

So $\mathbf{a} + \mathbf{b} = 9.54 \text{ m}$ at an angle of 33.0° to the horizontal

Summary

In this section you have learnt that:

- Vectors can be added graphically by drawing scale diagrams.
- Vectors can be expressed as components.

Review questions

- Vector **p** is 6 m in the x-direction. Vector **q** is 10 m in the y-direction.
 - Use the parallelogram method to work out $\mathbf{p} + \mathbf{q}$.
 - Use Pythagoras's theorem and trigonometry to work out $\mathbf{p} - \mathbf{q}$.
- A car travels 3 km due North then 5 km East. Represent these displacements graphically and determine the resultant displacement.
- Two forces, one of 12 N and another of 24 N, act on a body in such a way that they make an angle of 90° with each other. Find the resultant of the two forces.
- Two cars A and B are moving along a straight road in the same direction with velocities of 25 km/h and 30 km/h, respectively. Find the velocity of car B relative to car A.
- Two aircraft P and Q are flying at the same speed, 300 m s^{-1} . The direction along which P is flying is at right angles to the direction along which Q is flying. Find the magnitude of the velocity of the aircraft P relative to aircraft Q.
- Three vectors are: $\mathbf{a} = \begin{bmatrix} 1 \\ 4 \end{bmatrix}$, $\mathbf{b} = \begin{bmatrix} -3 \\ 5 \end{bmatrix}$, $\mathbf{c} = \begin{bmatrix} 2 \\ -9 \end{bmatrix}$
Work out the following:
 - $\mathbf{a} + \mathbf{b}$
 - $\mathbf{a} + \mathbf{c}$
 - $\mathbf{b} - \mathbf{c}$
 - $\mathbf{a} - \mathbf{c}$
 - $\mathbf{a} + \mathbf{b} + \mathbf{c}$
 What does the answer to part e) mean?
- Work out the magnitude and direction of the resultant force in the worked example on page 31.
- An aeroplane flies (1500, 3000, 200) m to point A and then (2000, -5000, -100) m to point B.
 - Work out the final displacement of the aeroplane.
 - Work out the magnitude of the displacement.
- Add the following pairs of vectors together, using the cosine and sine rules to work out the resultant vector.
 - a** is 4 m due west, **b** is 8 m at an angle of 50° above the horizontal
 - a** is 6 m due north, **b** is 4 m at an angle of 30° above the horizontal
 - a** is 7 m due west, **b** is 5 m at an angle of 65° below the horizontal

2.4 Multiplication of vectors

By the end of this section you should be able to:

- Use the geometric definition of the scalar product to calculate the scalar product of two given vectors.
- Use the scalar product to determine projection of a vector onto another vector.
- Test two given vectors for orthogonality.
- Use the vector product to test for collinear vectors.
- Explain the use of knowledge of vectors in understanding natural phenomena.

Multiplying by a scalar

Vectors can be multiplied by scalars. When you multiply a vector by a scalar, the magnitude of the vector changes, but not its direction.

Figure 2.25 shows the vector \mathbf{a} , which has a magnitude of 5 at an angle of 53° to the x-direction. It is multiplied by 2, which gives the vector $2\mathbf{a}$. The diagram shows that the magnitude has doubled but its direction is unchanged.

If we break \mathbf{a} down into its components and express it in column form, it becomes $\begin{bmatrix} 3 \\ 4 \end{bmatrix}$.

Multiplying it by 2 to give $2\mathbf{a}$ gives $\begin{bmatrix} 6 \\ 8 \end{bmatrix}$. If θ is the direction of the vector relative to the x-direction, we can see that $\tan \theta$ is the same for both \mathbf{a} and $2\mathbf{a}$

For \mathbf{a} $\tan \theta = 4/3$

For $2\mathbf{a}$ $\tan \theta = 8/6 = 4/3$

If you multiply a vector by a negative scalar, the direction of the vector is reversed.

For example, if \mathbf{a} is multiplied by -2 , then $-2\mathbf{a}$ is $[-6, -8]$

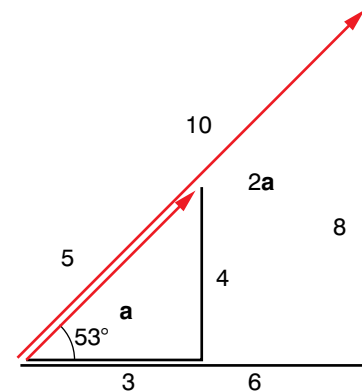

Figure 2.25 Multiplying a vector by a scalar

Scalar product

The scalar product of two vectors is when they are multiplied together to give a scalar quantity. The scalar product is also known as the dot product.

The scalar product of two vectors is defined as

$$\mathbf{a} \cdot \mathbf{b} = a_x b_x + a_y b_y$$

where the vectors are given in component form and are $\mathbf{a} = \begin{bmatrix} a_x \\ a_y \end{bmatrix}$ and $\mathbf{b} = \begin{bmatrix} b_x \\ b_y \end{bmatrix}$. a_x and b_x are the components in the x-direction and a_y and b_y are the components in the y-direction.

Worked example 2.4

\mathbf{a} is the vector $\begin{bmatrix} 4 \\ 4 \end{bmatrix}$ and \mathbf{b} is the vector $\begin{bmatrix} 7 \\ 3 \end{bmatrix}$.

Work out the scalar product of \mathbf{a} and \mathbf{b} .

$$\begin{aligned} \mathbf{a} \cdot \mathbf{b} &= a_x b_x + a_y b_y = \\ &(4 \times 7) + (4 \times 3) = \\ &28 + 12 = 40 \end{aligned}$$

The scalar product can also be expressed as:

$$\mathbf{a} \cdot \mathbf{b} = |\mathbf{a}| |\mathbf{b}| \cos \theta$$

where $|\mathbf{a}|$ and $|\mathbf{b}|$ are the magnitudes of the vectors \mathbf{a} and \mathbf{b} , respectively, and θ is the angle between the two vectors.

By rearranging this equation, we can calculate the angle between two vectors:

$$\cos \theta = \frac{(\mathbf{a} \cdot \mathbf{b})}{(|\mathbf{a}| |\mathbf{b}|)}$$

Worked example 2.5

What is the angle between the two vectors $\mathbf{a} = \begin{bmatrix} 4 \\ 4 \end{bmatrix}$ and $\mathbf{b} = \begin{bmatrix} 7 \\ 3 \end{bmatrix}$?

Draw a sketch of the vectors, as shown in Figure 2.26.

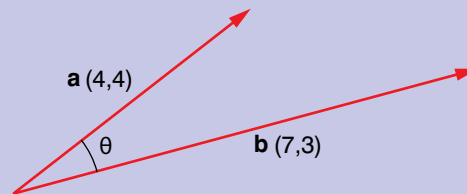

Figure 2.26 Vectors \mathbf{a} and \mathbf{b}

Work out the magnitudes of \mathbf{a} and \mathbf{b} using Pythagoras's theorem.

$$|\mathbf{a}| = \sqrt{(4^2 + 4^2)} = \sqrt{(16 + 16)} = \sqrt{32}$$

$$|\mathbf{b}| = \sqrt{(7^2 + 3^2)} = \sqrt{(49 + 9)} = \sqrt{58}$$

We already know from the previous worked example that $\mathbf{a} \cdot \mathbf{b} = 40$

$$\text{So } \cos \theta = 40 / (\sqrt{32} \times \sqrt{58}) = 40 / \sqrt{1856} = 0.93$$

$$\theta = \cos^{-1} 0.93 = 21.8^\circ$$

We can also use the scalar product to work out the scalar projection of one vector onto another vector. If the vector \mathbf{a} is projected on to vector \mathbf{b} as shown in Figure 2.27, the scalar projection gives the magnitude of the component of \mathbf{a} that is in the direction of \mathbf{b} .

The scalar projection of \mathbf{a} onto \mathbf{b} is given by:

$$|\mathbf{a}| \cos \theta$$

Worked example 2.6

Two vectors are $\mathbf{a} = \begin{bmatrix} 4 \\ 4 \end{bmatrix}$ and $\mathbf{b} = \begin{bmatrix} 7 \\ 3 \end{bmatrix}$. What is the scalar projection of \mathbf{a} on to \mathbf{b} ?

Sketch the two vectors and the projection of \mathbf{a} on to \mathbf{b} as shown in Figure 2.27.

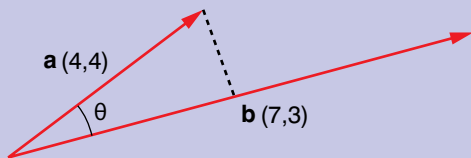

Figure 2.27 Scalar projection of \mathbf{a} on to \mathbf{b}

From worked example 2.5, $|\mathbf{a}| = \sqrt{32}$ and $\cos \theta = 0.93$

So the scalar projection of \mathbf{a} on to \mathbf{b} is $\sqrt{32} \times 0.93 = 5.25$

KEY WORDS

orthogonal at right angles. When two vectors are at right angles to each other, they are said to be orthogonal.

Vector product

The vector product of two vectors is when two vectors are multiplied together to produce another vector. It is given by the formula:

$$\mathbf{a} \times \mathbf{b} = |\mathbf{a}| |\mathbf{b}| \sin \theta \hat{n}$$

where $|\mathbf{a}|$ and $|\mathbf{b}|$ are the magnitudes of \mathbf{a} and \mathbf{b} , respectively, θ is the smaller angle between \mathbf{a} and \mathbf{b} (θ is between 0° and 180°) and \hat{n} is a unit vector, which is perpendicular to the plane that \mathbf{a} and \mathbf{b} are in.

The vector product can also be expressed as:

$$\mathbf{a} \times \mathbf{b} = (a_x b_y - a_y b_x) \hat{n}$$

The direction of \hat{n} is given by the right-hand rule, as shown in Figure 2.28.

If the vectors are in three dimensions, the vector product is a bit more complicated:

$$\mathbf{a} \times \mathbf{b} = (a_y b_z - a_z b_y) \mathbf{i} + (a_z b_x - a_x b_z) \mathbf{j} + (a_x b_y - a_y b_x) \mathbf{k}$$

Activity 2.8

The vectors \mathbf{g} and \mathbf{h} are $\begin{bmatrix} 7 \\ 0 \end{bmatrix}$ cm and $\begin{bmatrix} 5 \\ 3 \end{bmatrix}$ cm, respectively.

- Draw the vectors to scale.
- Find the resultant by drawing a parallelogram.
- Find the area of the parallelogram.
- Find the vector product of the two vectors

What do you notice?

Activity 2.7

Consider the vectors

$$\mathbf{a} = \begin{pmatrix} 4 \\ 6 \end{pmatrix}, \mathbf{b} = \begin{pmatrix} -9 \\ 6 \end{pmatrix}, \mathbf{c} = \begin{pmatrix} 3 \\ 5 \end{pmatrix}$$

and $\mathbf{d} = \begin{pmatrix} 10 \\ -6 \end{pmatrix}$

What is the angle between \mathbf{a} and \mathbf{b} ?

What is the angle between \mathbf{c} and \mathbf{d} ?

Can you see an easy way of checking to see if vectors are **orthogonal**?

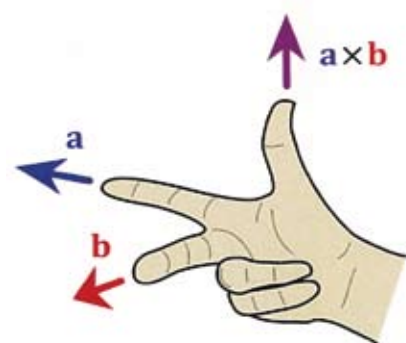

Figure 2.28 The right-hand rule for finding the direction of the unit vector in the vector product of two vectors

Project work

A ladder rests against a wall.

Plan and carry out an investigation into the forces being exerted on the ladder.

What directions are they acting in?

Are they in equilibrium?

Write your results up as a report using the writing frame on pages 19–20.

Activity 2.9

1. The vectors **d**, **e** and **f** are $\begin{bmatrix} -4 \\ 1 \end{bmatrix}$, $\begin{bmatrix} 1 \\ 4 \end{bmatrix}$ and $\begin{bmatrix} 4 \\ -1 \end{bmatrix}$, respectively.

Find:

- $\mathbf{d} \times \mathbf{e}$.
 - the angle between vectors **d** and **e**.
 - the area of the parallelogram formed by the resultant of **e** and **f**.
2. When vectors are collinear, they are either in the same direction as each other or in the opposite direction. So, the angle between them will be either 0° or 180° .

Can you find an easy way to test if vectors are collinear?

Discussion activity

In small groups, discuss other possible applications of vectors.

Report the results of your discussion back to the rest of the class.

We can work out the size of the angle by rearranging the equation for the vector product:

$$\sin \theta = \frac{(\mathbf{a} \times \mathbf{b})}{|\mathbf{a}| |\mathbf{b}| \hat{n}}$$

But we also know that $\mathbf{a} \times \mathbf{b} = (a_x b_y - a_y b_x) \hat{n}$, so

$$\sin \theta = \frac{(a_x b_y - a_y b_x)}{|\mathbf{a}| |\mathbf{b}|}$$

Applications of vectors

Vectors have many applications. They are extremely useful in physics and many other areas. Some applications are as follows.

- Analysing forces on a bridge.
- Analysing the motion of an aeroplane.
- Programming motion or the position of an object in a computer game or animation.
- Displaying graphics (in the form of vector graphics) so that the diagram can be resized easily without any loss of quality.
- Modelling and planning the trajectory (path) of a space probe.
- Analysing the motion of planets.
- Analysing magnetic fields.

These are just a few examples – there are many more. We can use vectors whenever there is a variable that has direction as well as magnitude.

Summary

- Multiplying a vector by a scalar changes the magnitude but not the direction of a vector.
- The scalar product of two vectors is $\mathbf{a} \cdot \mathbf{b} = a_x b_x + a_y b_y + a_z b_z = |\mathbf{a}| |\mathbf{b}| \cos \theta$
- The vector product of two vectors is $\mathbf{a} \times \mathbf{b} = |\mathbf{a}| |\mathbf{b}| \sin \theta \hat{n} = (a_x b_y - a_y b_x) \hat{n}$.

Review questions

- Vector **d** is 1 N at 50° to the x-direction.
Vector **e** is 3 N in the x-direction and 2 N in the y-direction.
Vector **f** is (6, 2).
Work out the following:
 - $2\mathbf{d}$
 - $3\mathbf{e}$
 - $-2\mathbf{f}$
 - $\frac{1}{2}\mathbf{d}$
 - $-\frac{3}{4}\mathbf{e}$
 - $0.25\mathbf{f}$

2. Four vectors are $\mathbf{a} = \begin{bmatrix} 4 \\ 10 \end{bmatrix}$, $\mathbf{b} = \begin{bmatrix} 2 \\ -5 \end{bmatrix}$, $\mathbf{c} = \begin{bmatrix} -6 \\ 15 \end{bmatrix}$, $\mathbf{d} = \begin{bmatrix} 15 \\ -6 \end{bmatrix}$
- Work out:
 - $\mathbf{a} \cdot \mathbf{b}$
 - $\mathbf{c} \cdot \mathbf{d}$
 - the angle between \mathbf{c} and \mathbf{d}
 - the projection of \mathbf{c} on to \mathbf{a}
 - Are the vectors \mathbf{a} and \mathbf{d} orthogonal?
3.
 - Express the unit vectors \mathbf{i} , \mathbf{j} and \mathbf{k} in column form.
 - Work out $\mathbf{i} \cdot \mathbf{j}$, $\mathbf{j} \cdot \mathbf{k}$ and $\mathbf{i} \cdot \mathbf{k}$. What does this tell you about the unit vectors?
4. Work out $\mathbf{i} \times \mathbf{i}$, $\mathbf{j} \times \mathbf{j}$ and $\mathbf{k} \times \mathbf{k}$. Explain your answers.

End of unit questions

- Construct a glossary of the key terms in this unit. You could add it to the one you made for Unit 1.
- What is the scalar product of two vectors?
- Given that $\mathbf{a} = 3\mathbf{i} - \mathbf{j} + 2\mathbf{k}$ and $\mathbf{b} = 2\mathbf{i} + \mathbf{j} - 2\mathbf{k}$, find
 - $\mathbf{a} \cdot \mathbf{b}$
 - the included angle between the vectors to 1d.p
- If $\mathbf{p} = 4\mathbf{i} + 3\mathbf{j} + 2\mathbf{k}$ and $\mathbf{q} = 2\mathbf{i} - \mathbf{j} + 11\mathbf{k}$, find
 - $\mathbf{p} \cdot \mathbf{q}$
 - $\mathbf{q} \cdot \mathbf{p}$
- If $\mathbf{x} = \begin{bmatrix} 2 \\ -3 \\ -4 \end{bmatrix}$ and $\mathbf{y} = \begin{bmatrix} -2 \\ 14 \\ 1 \end{bmatrix}$, calculate
 - $\mathbf{x} \cdot \mathbf{y}$
 - $\mathbf{y} \cdot \mathbf{x}$
- What is the vector product of two vectors?
- Find the vector product $\mathbf{a} \times \mathbf{b}$ if $\mathbf{a} = 3\mathbf{i} - 2\mathbf{j} + 5\mathbf{k}$ and $\mathbf{b} = 7\mathbf{i} + 4\mathbf{j} - 8\mathbf{k}$.
- If $\mathbf{a} = 8\mathbf{i} + \mathbf{j} - 2\mathbf{k}$ and $\mathbf{b} = 5\mathbf{i} - 3\mathbf{j} + \mathbf{k}$ show that
 - $\mathbf{a} \times \mathbf{b} = -5\mathbf{i} - 18\mathbf{j} - 29\mathbf{k}$
 - $\mathbf{b} \times \mathbf{a} = 5\mathbf{i} + 18\mathbf{j} + 29\mathbf{k}$
- How can you test to see if vectors are:
 - orthogonal
 - collinear?
- Give some applications of vectors.

Contents

Section	Learning competencies
3.1 Motion in a straight line (page 39)	<ul style="list-style-type: none"> • Describe motion using vector analysis. • Define the term reference frame. • Explain the difference between average speed (velocities) and instantaneous speed (velocity). • Solve numerical problems involving average velocity and instantaneous velocity. • Define instantaneous acceleration. • Solve problems involving average and instantaneous acceleration. • Solve quantitative and qualitative kinematics problems related to average and instantaneous velocity and acceleration. • Derive equations of motion for uniformly accelerated motion. • Apply equations of uniformly accelerated motion in solving problems. • Draw graphs from the kinematics equations. • Interpret $s-t$, $v-t$ and $a-t$ graphs. • Solve numerical kinematics problems. • Relate scientific concepts to issues in everyday life. • Explain the science of kinematics underlying familiar facts, observations and related phenomena. • Describe the conditions at which falling bodies attain their terminal velocity.
3.2 Motion in a plane (page 51)	<ul style="list-style-type: none"> • Analyse and predict, in quantitative terms, and explain the motion of a projectile with respect to the horizontal and vertical components of its motion. • Derive equations related to projectile motion. • Apply equations to solve problems related projectile motion. • Define centripetal force and centripetal acceleration. • Identify that circular motion requires the application of a constant force directed toward the centre of the circle. • Distinguish between uniform and non-uniform circular motion. • Analyse the motion of a satellite. • Identify that satellites are projectiles that orbit around the Earth. • Analyse and predict, in quantitative terms, and explain uniform circular motion in the horizontal and vertical planes with reference to the forces involved. • Describe Newton's law of universal gravitation, apply it quantitatively and use it to explain planetary and satellite motion. • Determine the relative velocities of bodies moving at an angle relative to each other. • Use the relative velocity equation to convert from one measurement to the other in reference frames in relative motion.

You should be familiar with the four equations of motion from your work in Grade 10:

$$s = \frac{1}{2}(u + v)t$$

$$s = ut + \frac{1}{2}at^2$$

$$v = u + at$$

$$v^2 = u^2 + 2as$$

where s = distance or displacement, v = final speed or velocity, u = initial speed or velocity, a = acceleration and t = time.

In this unit you will be considering motion in more than one direction, using vectors. Understanding how an object moves and being able to predict how it will move is vital to planning things such as the launch of rockets into space.

3.1 Motion in a straight line

By the end of this section you should be able to:

- Describe motion using vector analysis.
- Define the term reference frame.
- Explain the difference between average speed (velocities) and instantaneous speed (velocity).
- Solve numerical problems involving average velocity and instantaneous velocity.
- Define instantaneous acceleration.
- Solve problems involving average and instantaneous acceleration.
- Solve quantitative and qualitative kinematics problems related to average and instantaneous velocity and acceleration.
- Derive equations of motion for uniformly accelerated motion.
- Apply equations of uniformly accelerated motion in solving problems.
- Draw graphs from the kinematics equations.
- Interpret $s-t$, $v-t$ and $a-t$ graphs.
- Solve numerical kinematics problems.
- Relate scientific concepts to issues in everyday life.
- Explain the science of kinematics underlying familiar facts, observations, and related phenomena.
- Describe the conditions at which falling bodies attain their terminal velocity.

KEY WORDS

frame of reference *a rigid framework or coordinate system that can be used to measure the motion of an object*

Frame of reference

You have already met several **frames of reference** in your studies – for example, coordinate grids in maths. Different people in different parts of Ethiopia speak different languages and have different cultures. They have different frames of reference. For example, people who speak Amharic as their first language have a different frame of reference from people who speak Afan or Orono as their first language.

Discussion activity

Discuss the story in small groups. What implications does it have for your work in physics?

Report the results of your discussion back to the rest of the class.

The seven blind men and the elephant

There is an old Indian story about seven blind men and an elephant. The men had not come across an elephant before. Each man was asked to describe it. The first felt its side and described it as a wall; the second felt its trunk and described it as a snake; the third felt its tusk and described it as a spear; the fourth felt its leg and described it as a tree trunk; the fifth felt its tail and described it as a piece of rope and the sixth felt the effects of its ear and described it as a natural fan. The seventh blind man took the time to investigate the elephant more fully – he felt all of the parts and knew exactly what the elephant was like.

Activity 3.1

Student A and student B stand facing each other about 2 m apart. Student C walks between the two students (Figure 3.1).

- How do students A and B describe the movement of student C?
- How do the rest of the class describe the movement of student C?
- Do they describe it in the same way? If not, why not?
- Which description is most useful?
- How does your frame of reference affect your observations?
- Repeat the activity, but this time with student B walking towards student A, so that student B walks in front of student C.

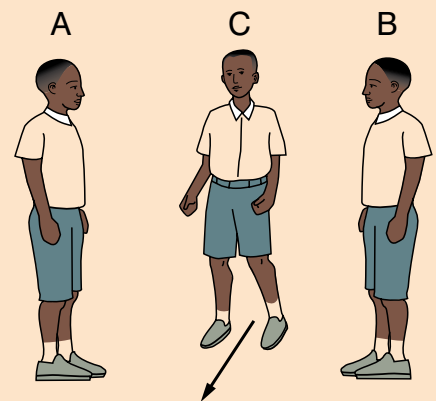

Figure 3.1 Students observing the motion of a third student

When you observe something, you use a frame of reference. You should have concluded from Activity 3.1 that you need an agreed frame of reference so that everyone can understand each other’s observations. If people use different frames of reference, their observations will not be the same.

Activity 3.2

A body has a displacement of 10 m at an angle of 30° to the horizontal.

- Is this enough information to describe the displacement uniquely?
- What additional information do you need?
- What would be a better way of expressing the displacement?

You should have discovered from Activity 3.2 that there are four possible positions for the body. When we are giving the displacements and velocities of objects, we need a frame of reference that will describe the vector uniquely. One way of doing this is to give the vector in component form – give the distance in the x-direction and the distance in the y-direction. We use the coordinate grid in all four quadrants.

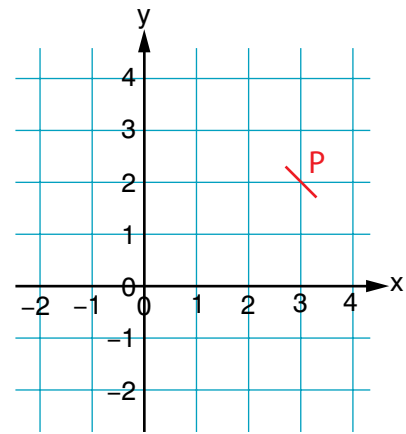

Figure 3.2 A coordinate grid is a frame of reference. You give the horizontal component of the coordinates of the point P before the vertical component.

Average and instantaneous velocity

In everyday speech, velocity is another name for speed, but remember that in physics they are not the same. Speed is a scalar quantity – it has magnitude but no directions, whereas velocity is a vector and has both magnitude *and* direction.

Activity 3.3

One student walks between two points 4 m apart at a constant rate in a straight line. The student should take 3 seconds to cover the distance.

Another student walks between the same two points taking 3 seconds, but in a path that is not a straight line.

Repeat, but this time with both students travelling at constant rates – one travels in a straight line, the other does not.

Observe the motion of the two students. What are the average and instantaneous velocities of the two students? Are they the same?

Average velocity is the total displacement, or distance travelled in a specified direction, divided by the total time taken to travel the displacement. This is shown in Figure 3.3.

Expressed mathematically the average velocity is

$$v_{\text{av}} = \frac{s_2 - s_1}{t_2 - t_1}$$

As the difference in displacement decreases, the two points get much closer together and the average velocity tends towards the **instantaneous velocity**, which is the velocity at a point. Expressed mathematically, this is

$$v_{\text{inst}} = \Delta s / \Delta t \text{ as } \Delta t \rightarrow 0$$

KEY WORDS

average velocity *difference in displacement between two points divided by the time taken to travel between the two points*

instantaneous velocity *velocity of an object at a point*

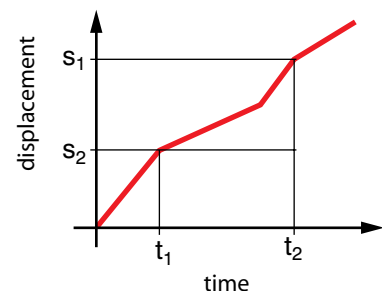

Figure 3.3 Calculating average velocity

KEY WORDS

average acceleration *change in velocity divided by the time taken for the change to happen*

instantaneous acceleration *acceleration of an object at a point*

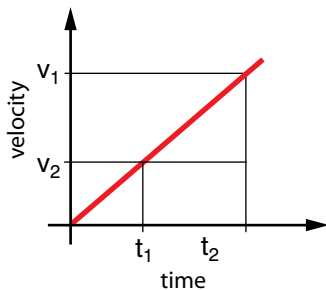

Figure 3.5 Calculating average acceleration

Activity 3.4

Repeat Activity 3.3, but this time consider the acceleration of the students.

Are they accelerating?
Explain why you think they are or are not.

Worked example 3.1

A bus travels 60 km due north in 1 hour. It then travels 75 km due east in 2 hours.

What is the average velocity of the bus?

First draw a sketch to show the displacement of the bus (Figure 3.4).

The total displacement of the bus is (75, 60) km.

The total time taken is $1 + 2 = 3$ hour.

The average velocity of the bus is $(75/3, 60/3) = (25, 20)$ km/h.

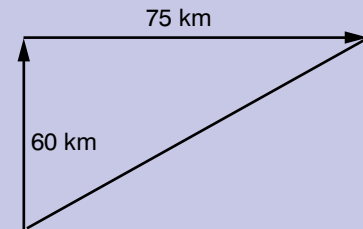

Figure 3.4 Displacement of bus

Average and instantaneous acceleration

Average acceleration is the change in velocity, divided by the total time taken for the change in velocity. This is shown in Figure 3.5.

Expressed mathematically the average acceleration is:

$$a_{\text{av}} = \frac{v_2 - v_1}{t_2 - t_1}$$

As the difference in velocity decreases, the two points get much closer together and the average acceleration tends towards the **instantaneous acceleration**, which is the acceleration at a point. Expressed mathematically, this is:

$$a_{\text{inst}} = \Delta v / \Delta t \text{ as } \Delta t \rightarrow 0$$

Average and instantaneous acceleration can be quite different. For example, consider the journey of a bus. The initial velocity of the bus is 0 m/s, as it starts off. When it reaches its destination, its final velocity is also 0 m/s. So the average acceleration over the whole journey is 0 m/s².

During the course of the journey the instantaneous acceleration at different times will vary a great deal. As the bus pulls away at the start, its instantaneous acceleration will be positive – probably about +1 m/s². When the bus slows down, the acceleration will be negative, perhaps about -1 m/s². If it has to do an emergency stop, the negative acceleration will be much higher.

As the time interval over which you are measuring the change in velocity gets smaller and smaller, you approach the instantaneous acceleration. In the limit, the instantaneous acceleration is when the time interval is infinitely small.

Motion with constant acceleration

Discussion activity

Consider the following velocities and accelerations of a particle. In each case, decide if the particle is speeding up or slowing down.

Velocity (m/s)	Acceleration (m/s ²)
+4	+2
+4	-2
-4	+2
-4	-2

What conclusions can you draw about how you can tell if a particle is speeding up or slowing down when you know its velocity and acceleration?

You should have come to the conclusion that if the velocity and acceleration of an object have the same sign, the object is speeding up. If they have different signs, the object is slowing down.

Activity 3.5

Your teacher will set up a ramp. You should record how far a toy car travels down the ramp in equal intervals of time (Figure 3.6).

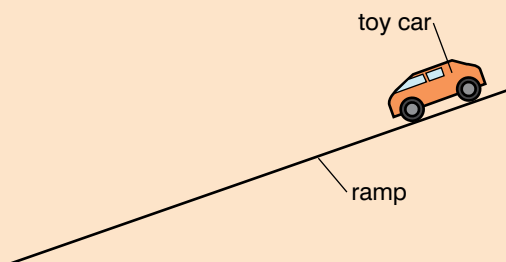

Figure 3.6 Ramp for Activity 3.5

- Plot graphs of distance against time and distance against (time)². What do you notice about the graphs?
- Work out the average velocity and acceleration for different time periods. What do you notice?
- Write a report setting out how you carried out the activity and your results.
- Use the framework given on pages 19–20.

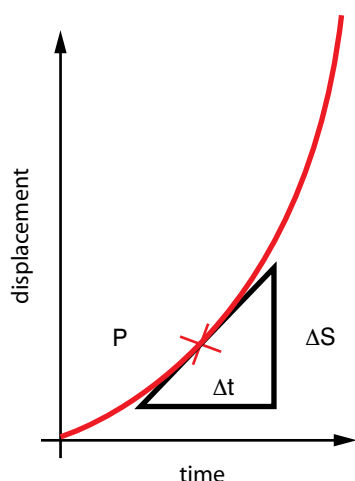

Figure 3.7 Finding the instantaneous velocity from a distance–time graph

The graph of displacement against time for a toy car moving down the ramp will have the form shown in Figure 3.7. If we draw a line that is parallel to the curve at a particular point (a tangent to the curve), we can find the instantaneous velocity by finding the gradient of the line.

Worked example 3.2

The driver of a train travelling at 40 m/s applies the brakes as the train enters a station. The train slows down at a rate of 2 m/s. The platform is 400 m long.

Will the train stop in time?

First, extract the information that we know:

initial velocity, $u = 40$ m/s

final velocity, $v = 0$ m/s

$a = -2$ m/s²

We need to find the stopping distance of the train, s .

We need to select the appropriate equation, which is:

$$v^2 = u^2 + 2as$$

(Look back at page 39, if you are not sure)

Rearranging the equation to make s the subject:

$$2as = v^2 - u^2$$

$$s = (v^2 - u^2)/2a$$

Substituting in the values:

$$s = ((0)^2 - (40)^2)/(2 \times -2)$$

$$s = -1600/-4$$

$$s = 400 \text{ m}$$

Check that the dimensions are correct:

$$s = ((\text{m/s})^2 - (\text{m/s})^2)/(\text{m/s}^2) = \text{m}$$

So the dimensions are correct.

The train will stop in time.

KEY WORDS

free body diagram a simplified diagram of an object showing all the forces acting on it. It can also show the size and direction of the forces.

Freely falling bodies

In Grade 9 you used a weight falling under gravity to pull a person on a board or a bicycle. The weight was being accelerated by the force due to gravity.

A falling object will show almost constant acceleration on its journey. The acceleration is the acceleration due to gravity, which we call g . Close to the surface of the Earth its value is about 9.8 m/s².

The acceleration is ‘almost’ constant because in real life air resistance will oppose the object’s motion and so reduce its acceleration. If the object starts from rest, this air resistance will be zero initially, but as the object speeds up the air resistance on it will increase.

We can also show the forces acting on a body using a **free body diagram**. Figure 3.8 shows free body diagrams for a falling particle at different times in its fall.

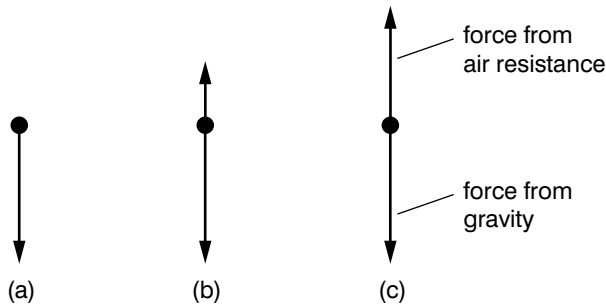

Figure 3.8 A free body diagram showing the forces on a particle at different times during its fall: (a) at the start of the fall; (b) during the fall; (c) at the end of the fall

If you are asked to do a calculation on a falling body, you will have to assume that air resistance has a negligible effect on its progress unless you are told otherwise.

Worked example 3.3

A stone is dropped down a well. You hear a splash after 2 s. Work out the depth of the well. What assumptions have you made in working out your answer?

Assume that movement upwards is positive.

In this case, $u = 0 \text{ m/s}$, $t = 2 \text{ s}$ and $g = -9.8 \text{ m/s}^2$.

We need to find s . The equation linking u , a , t and s is $s = ut + \frac{1}{2}at^2$

Substituting the values into the equation, we get:

$$s = (0 \times 2) + (\frac{1}{2} \times 9.8 \times 2^2) = 0 - 19.6 \text{ m.}$$

So the well is about 20 m deep.

Our assumptions were that air resistance on the stone was negligible and also that the speed of sound is so fast that the time taken to hear the splash at the top of the well can be ignored.

Activity 3.6

Place two marbles or steel balls with different masses on a table. Flip both balls together with the ruler, so that they both go off the edge of the table at the same time.

- What do you notice about when the balls hit the floor?
- How do you explain this?

Activity 3.7

Punch two holes near the bottom of a plastic cup on opposite sides. Put the cup in a bowl and fill the cup with water.

- What happens to the water?

Fill the cup with water again, while holding it over the bucket. Drop the cup into the bucket from a height of at least 2 m.

- What happens to the water while the cup is falling?
- Can you explain why this happens?

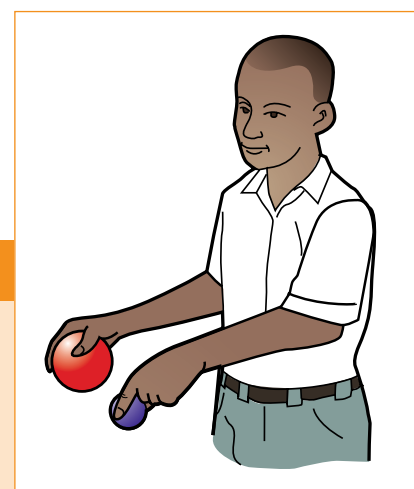

Figure 3.9 The balls are dropped at the same time. Will they hit the ground at the same time?

Galileo's thought experiment

Galileo Galilei (1564–1642) did much of his work as 'thought experiments'. In one of them, he thought about what would happen if he dropped two balls with different masses at the same time from the leaning tower of Pisa. Which one would hit the ground first?

There are three possible outcomes:

- both balls hit the ground at the same time
- the heavier ball falls faster than the lighter one
- the lighter ball falls faster than the heavier one.

He proposed that if the lighter ball covered the distance in a certain time, then if the heavier ball had twice the mass it would cover the distance in half the time.

What happens if we tie the balls together? Suppose that the heavier ball falls faster than the lighter one – it will be slowed down by the lighter ball, which will act a bit like a parachute. But once the balls are tied together, the masses of the two balls are combined and so the two balls should fall faster (think of two balls being tied very closely together).

According to these lines of thinking, when the two balls are tied together they will fall both faster and slower, which is a contradiction! There is only one way to solve this. Both balls fall with the same velocity and will land on the ground at the same time.

Terminal velocity

Figure 3.8 shows that as a particle falls, the force from air resistance increases during its fall. This force increases as the velocity of the particle increases. If the particle is falling for long enough, the force from air resistance will be the same as the force from gravity. As there is no net force on the particle, there is no net acceleration on it and its velocity will not increase any more. This velocity is known as the terminal velocity. You will return to the subject of terminal velocity in Unit 8.

Graphical representation of motion

Displacement–time graphs

Figure 3.10 might represent two people who start on a straight-line race. Every second their distance from the starting point is recorded, and the results plotted on a graph.

One of the runners sets a fast pace so his distance away from the start increases rapidly with time. The other one is much slower; by the time his opponent has reached the end he has covered only half the distance and promptly stops for a rest.

It should be apparent from this example that the steeper the slope, the faster the velocity. A uniform slope means a constant (steady velocity).

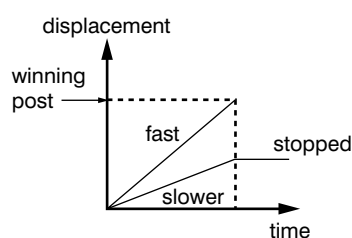

Figure 3.10 The steeper the slope, the faster the velocity

Worked example 3.4

What was the velocity of the journey shown in Figure 3.11?

To work out the velocity of the journey shown in Figure 3.11 find the gradient of the graph as follows:

$$\text{velocity} = \text{displacement}/\text{time taken} = 30 \text{ m}/5 \text{ s} = 6 \text{ m/s}$$

This is both the average velocity and the instantaneous velocity at every moment in the journey because the velocity was constant.

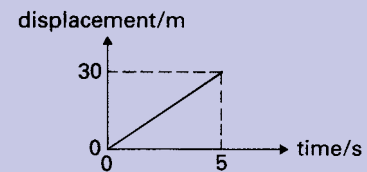

Figure 3.11 Displacement–time graph for a journey

Velocity–time graphs

An alternative way of recording a journey is to describe not where you are but what your velocity is at each moment. This will give you a velocity–time graph (Figure 3.12).

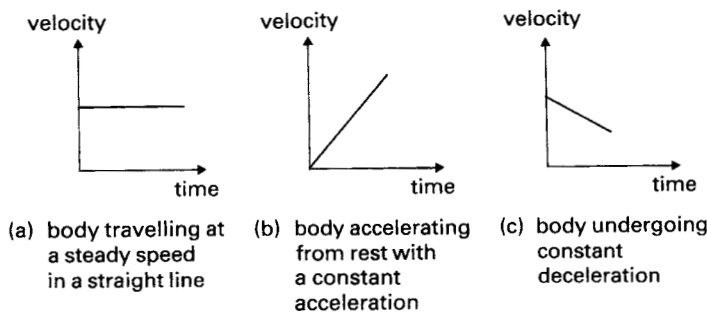

Figure 3.12 Velocity–time graphs

The slope of the graph is your acceleration. The steeper the upwards slope, the greater the acceleration.

It is also possible to deduce how far you have travelled by using a velocity–time graph. Figure 3.14 illustrates the straightforward case of something going at a constant velocity of 2 m/s for 10 s . The displacement will of course be 20 m .

Worked example 3.6

What is the distance travelled in the journey shown in Figure 3.14?

The area of the shaded rectangle is its length multiplied by its width. Read the lengths of the sides from the scales of the graph – do not use a ruler! The area is $2 \text{ m/s} \times 10 \text{ s}$, which works out to be 20 metres .

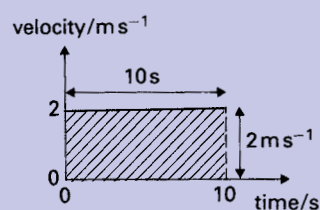

Figure 3.14 You can use a velocity–time graph to find out how far you have travelled.

Activity 3.8

Draw displacement–time, velocity–time and acceleration–time graphs to show the motion of each of the following:

- a bus moving at a constant velocity
- a car accelerating at a constant rate
- a car decelerating at a constant rate.

Compare what each graph shows you for the three types of motion.

Worked example 3.5

What is the acceleration shown on the graph in Figure 3.13?

$$\begin{aligned} \text{acceleration} &= \text{change in velocity}/\text{time taken} \\ &= (8 \text{ m/s} - 2 \text{ m/s})/2 \text{ s} \\ &= 3 \text{ m/s}^2 \end{aligned}$$

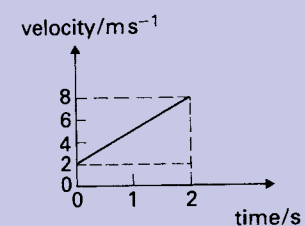

Figure 3.13 A velocity–time graph

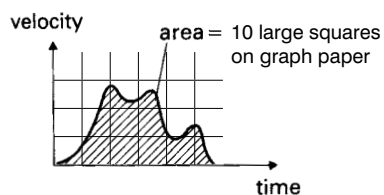

Figure 3.15 The shaded area represents the displacement

This is a particular example of a general rule: the area under a velocity–time graph is the displacement.

Look now at Figure 3.15. You can estimate the area under the graph by counting the number of squares on the graph paper that are under the line. Let us suppose you estimate the area under the line to be 10 large squares on the graph paper. To convert this to find the displacement the journey has produced, you must look at the scales used. Suppose the scale on the time axis is ‘one unit represents 5 s’, while on the vertical axis, one unit represents a velocity of 2 m/s. On this scale, each of the unit squares on the graph paper will have an area of $2 \text{ m/s} \times 5 \text{ s} = 10 \text{ m}$. Therefore the 10 large squares under the graph mean a displacement of 100 m.

Worked example 3.7

A body starts from rest with a constant acceleration of 3 m/s^2 . How far will it have travelled after 4 s?

Method 1: sketch the velocity–time graph, but it does not have to be to scale (Figure 3.16).

displacement = area under velocity–time graph =
 area of triangle = $\frac{1}{2}$ base \times height
 = $\frac{1}{2} \times 4 \text{ s} \times 12 \text{ m/s} = 24 \text{ m}$

Method 2: reason the problem like this. Over the 4 s, the body speeds up steadily from 0 to 12 m/s. Therefore:

Average velocity over the whole journey = $(0 + 12)/2 \text{ m/s} = 6 \text{ m/s}$

If you travel at an average velocity of 6 m/s for 4 s:

displacement = average velocity \times time = $6 \text{ m/s} \times 4 \text{ s} = 24 \text{ m}$.

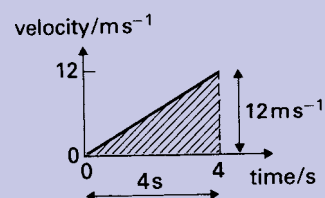

Figure 3.16 How far has the body travelled after 4 seconds?

Activity 3.9

A ball is thrown vertically upwards with a speed of 20 m/s.

Use the equations of motion to work out its velocity and displacement every 0.5 seconds.

Plot graphs of the following:

- displacement against time
- velocity against time
- the path of the ball.

What similarities and differences are there between your graphs?

Worked example 3.8

A train is at rest at a station. The train then moves away from the station and after 20 seconds, its velocity is 15 m/s and moves at this velocity for 60 seconds. Its velocity increases to 20 m/s over 5 seconds. It moves at a velocity of 20 m/s for 120 seconds and then slows down to come to a stop after a further 30 seconds.

- Draw a velocity–time graph for the train’s journey.
- During which period was the acceleration of the train the highest?
- How far did the train travel during this time?

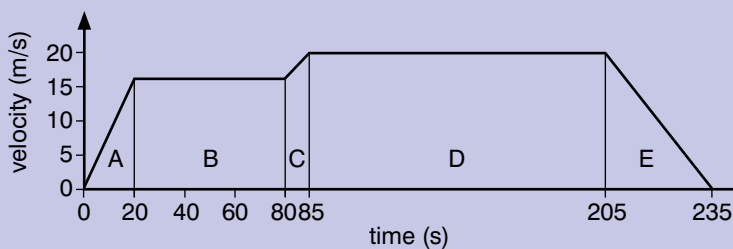

Figure 3.17

- acceleration = change in velocity \div time taken.

The acceleration of the train is the highest where the slope of the graph is the steepest.

In areas B and D, the graph is flat, and there is no increase or decrease in velocity, so the acceleration is zero.

In area A, acceleration = $15/20 = 0.75 \text{ m/s}^2$

In area C, acceleration = $5/5 = 1 \text{ m/s}^2$

In area E, acceleration = $-20/30 = -0.67 \text{ m/s}^2$

So the acceleration was highest in area C, from 80 to 85 seconds after the start of the journey.

- Displacement = area under the graph = area A + area B + area C + area D + area E

$$\begin{aligned}
 &= \left(\frac{1}{2} \times 20 \text{ s} \times 15 \text{ m/s}\right) + (60 \text{ s} \times 15 \text{ m/s}) + \left(\frac{1}{2} \times 5 \text{ s} \times 5 \text{ m/s}\right) \\
 &+ (5 \text{ s} \times 15 \text{ m/s}) + (120 \text{ s} \times 20 \text{ m/s}) + \left(\frac{1}{2} \times 30 \text{ s} \times 20 \text{ m/s}\right) \\
 &= 150 \text{ m} + 900 \text{ m} + 12.5 \text{ m} + 75 \text{ m} + 2400 \text{ m} + 300 \text{ m} \\
 &= 3837.5 \text{ m}
 \end{aligned}$$

Activity 3.10

Draw some simple graphs of motion to illustrate the following:

- displacement–time
- velocity–time.

Practise acting out the motion represented by your graph until you can do it without any pauses.

How did you know to move in the way that you did when acting out the motion of your graphs?

Summary

In this section you have learnt that:

- A frame of reference is needed when recording measurements.
- When the velocity and acceleration of an object have the same signs, the object is speeding up; when they have opposite signs, the object is slowing down.
- Gravity provides a uniform acceleration.
- Two freely falling objects that are dropped at the same time fall at the same velocity when there is no air resistance.
- The forces on a falling object can be shown on a free body diagram.
- The motion of objects can be represented on displacement–time and velocity–time graphs.
- The displacement of an object is given by the area under a velocity–time graph.

Review questions

1. After 2 hours, the displacement of a car is 150 km north. The initial displacement of the car is 0. What is the average velocity of the car?
2. A car travels 100 km due East in 2 hours. It then travels 50 km South in 1 hour. What is its average velocity?
3. A man runs 300 m West in 60 seconds. He then runs 100 m North-west in 20 seconds.
What is his average velocity in metres per second?
4. To get to school, a girl walks 1 km North in 15 minutes. She then walks 200 m South-west in 160 seconds.
What is the girl's average velocity for her walk to school?
5. A body sets off from rest with a constant acceleration of 8.0 m/s^2 . What distance will it have covered after 3.0 s?
6. A car travelling at 5.0 m/s starts to speed up. After 3.0 s its velocity has increased to 11 m/s.
 - a) What is its acceleration? (Assume it to be uniform.)
 - b) What distance does it travel while speeding up?
7. An aeroplane taxis onto the runway going at 10 m/s. If it can accelerate steadily at 3.0 m/s^2 and its take-off speed is 90 m/s, what length of runway will it need?
8. A motorist travelling at 18 m/s approaches traffic lights. When he is 30 m from the stop line, they turn red. It takes 0.7 s before he can react by applying the brakes.



Figure 3.18 An aeroplane taking off from Addis Ababa airport

- The car slows down at a rate of 4.6 m/s^2 . How far from the stop line will he come to rest and on which side of it?
9. A falling stone accelerates at a constant rate of 10 m/s^2 . It is dropped from rest down a deep well, and 3 s later a splash is heard as it hits the water below.
 - a) How fast will it be moving as it hits the water?
 - b) What will be its average speed over the three seconds?
 - c) How deep is the well?
 - d) What have you assumed about the speed of sound?
 10. A ball is thrown at a velocity of 15 m/s vertically upwards.
 - a) What height will the ball reach before it starts to fall?
 - b) How long will the ball take to reach this maximum height?
 11. Draw displacement–time and velocity–time graphs to illustrate the motion of the ball in question 10.
 12. Abeba walks to school. She walks 1 km in 15 minutes. She meets her friend Makeda – they talk for 5 minutes and then carry on walking to school. They walk 800 m in 10 minutes.
 - a) Draw a displacement–time graph to show Abeba’s journey to school.
 - b) What was the average velocity of Abeba’s journey? Give your answer in m/s
 - c) When was Abeba walking the fastest? Explain your answer.
 13. Dahnay travels on a bus to school. He gets on the bus, which then accelerates from rest to 18 m/s in 20 seconds. The bus travels at this velocity for 60 seconds. The bus slows down and comes to rest in 15 seconds. It is stationary for 30 seconds while more people get on the bus. The bus then accelerates to a velocity of 20 m/s in 25 seconds. It travels at 20 m/s for 5 minutes and then slows down to come to rest in a further 20 seconds, where Dahnay gets off the bus.
 - a) Draw a velocity–time graph to show the journey of the bus.
 - b) Between which times is the acceleration of the bus the greatest?
 - c) How far does Dahnay travel on the bus?

3.2 Motion in a plane

By the end of this section you should be able to:

- Analyse and predict, in quantitative terms, and explain the motion of a projectile with respect to the horizontal and vertical components of its motion.
- Derive equations related to projectile motion.
- Apply equations to solve problems related projectile motion.

- Define centripetal force and centripetal acceleration.
- Identify that circular motion requires the application of a constant force directed toward the centre of the circle.
- Distinguish between uniform and non-uniform circular motion.
- Analyse the motion of a satellite.
- Identify that satellites are projectiles that orbit around the Earth.
- Analyse and predict, in quantitative terms, and explain uniform circular motion in the horizontal and vertical planes with reference to the forces involved.
- Describe Newton's law of universal gravitation, apply it quantitatively and use it to explain planetary and satellite motion.
- Determine the relative velocities of bodies moving at an angle relative to each other.
- Use the relative velocity equation to convert from one measurement to the other in reference frames in relative motion

KEY WORDS

projectile *an object that is propelled through space by a force. The action of the force ceases after the projectile is launched.*

trajectory *the path a moving object follows through space*

Projectile motion

A **projectile** is an object that has been launched into the air by the action of a force. A ball that is thrown or a football which is kicked into the air are both projectiles. Javelins thrown in athletics and bullets fired from guns are also projectiles. If the force continues, for example, in a rocket, the object is not a projectile. However, if the force stops, the rocket then becomes a projectile.

You came across the motion of projectiles in Grade 10. Activity 3.11 will remind you of what you learned earlier.



Figure 3.19 *This ball becomes a projectile when the force stops acting on it.*

Activity 3.11

Position a ruler at the edge of a table, with one end over the edge. Put one coin on the end of the ruler that is over the edge of the table, as shown in Figure 3.20. Place the other coin on the table by the ruler. Quickly pivot the ruler about the other end so that the coin on the table is hit by the ruler. This coin will be fired off the table with a horizontal velocity. The other coin should fall off the ruler and drop straight downwards.

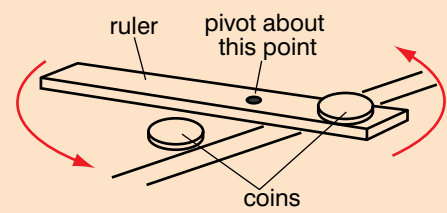
Figure 3.20

When do the coins hit the floor?

Try again with a different height and a different initial horizontal velocity.

Worked example 3.9

A ball is thrown with a velocity of 18 m/s at an angle of 56° above the horizontal.

Neglecting air resistance

- how high will it rise?
- how long will the ball spend in the air before it hits the ground?
- what is the range of the ball?

First we need to resolve the vector into its vertical and horizontal components (Figure 3.21).

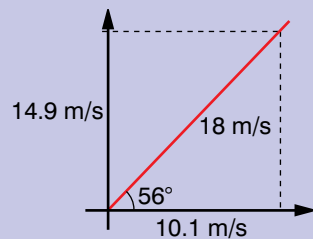
Figure 3.21 Resolving the horizontal and vertical components of the vector

vertical velocity, $v_v = 18$

$$\sin 56^\circ = 14.9 \text{ m/s}$$

horizontal velocity, $v_h = 18$

$$\cos 56^\circ = 10.1 \text{ m/s}$$

The **trajectory** of the ball is shown in Figure 3.22.

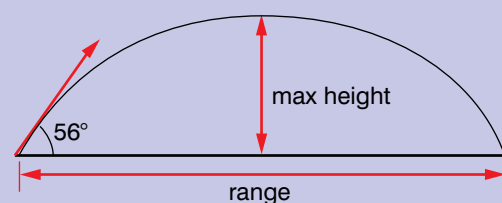
Figure 3.22 Trajectory of the ball

- At the maximum height, the ball has stopped moving upwards and is momentarily at rest.

We only need to consider the vertical component of the motion.

We know the following:

$$u = 14.9 \text{ m/s}$$

$$v = 0$$

$$a = -9.8 \text{ m/s}^2 \text{ (the minus sign is there)}$$

because the force of gravity is *slowing the ball down* while it is moving upwards, which is the same as decelerating.

We need to find s , so must use $v^2 = u^2 + 2as$.

Substituting in the values

$$0^2 = 14.9^2 + (2 \times -9.8 \times s)$$

$$19.6s = 220.01$$

$$s = 11.3 \text{ m}$$

- To find the time of the flight, we must realise that the upward journey and the downward one are symmetrical – in other words, the time to go up is the same as the time taken to descend. To find the complete time taken, all we do is work out how long it takes to reach the top then double it.

The simplest way will be to use $v = u + at$.

In this case, to find the time at the top:

$$0 = 14.9 + (-9.8t)$$

$$9.8t = 14.9$$

$$t = 1.52 \text{ s.}$$

Thus the full time of the flight is $1.52 \times 2 = 3.04 \text{ s.}$

- To find the range of the ball, we need to consider the horizontal component of the motion.

Horizontally, in the absence of air resistance, there is no force to slow the ball down so it keeps travelling along at the same horizontal speed. This will not change until the ball hits something that can supply a force to stop it.

We have found that the ball will hit the ground after 3.04 s.

So the range is $3.04 \text{ s} \times 10.1 \text{ m/s} = 30.7 \text{ m}$

KEY WORDS

maximum height *the vertical distance to the highest point reached by a projectile and the point at which the projectile is momentarily at rest*

range *the horizontal distance travelled by a projectile*

time of flight *the duration of a projectile's motion from launch to landing*

DID YOU KNOW?

Projectile motion can be used to model the motion of a stone when it is fired from a catapult and the motion of a frog when it jumps to catch a fly.

Activity 3.12

A ball is thrown at a speed of 15 m/s at an angle of 30° to the horizontal.

Resolve the movement of the ball into its horizontal and vertical components.

Use the equations of motion to work out the components of the ball's velocity and displacement every 0.5 seconds.

Plot graphs of the following:

- displacement against time, for each component
- velocity against time for each component
- the path of the ball.

What similarities and differences are there between your graphs?

The two components of velocity are independent of each other – the vertical component changes because of the effects of gravity, but the horizontal component is unaffected.

We can use the equations of motion to predict and describe the motion of the ball in the worked example above in vector form. The velocity of the ball could be given as $(14.9 - 9.8t, 10.1)$ and the displacement as $(14.9t - 4.9t^2, 10.1t)$.

We can also use the equations of motion to derive equations which will give the **maximum height** and **range** of the projectile, and the total **time of flight** of the projectile.

Using the equation $v^2 = u^2 + 2as$, at the maximum height, $v_{\text{vert}} = 0$, and $a = -g$.

$$\text{So, } 0 = u_{\text{vert}}^2 - 2gs$$

Rearranging the equation gives:

$$s = u_{\text{vert}}^2 / 2g$$

To derive an equation for the time of the flight of the projectile, use the equation $v = u + at$.

At the maximum height, $v_{\text{vert}} = 0$ and $a = -g$.

$$\text{So } 0 = u_{\text{vert}} - gt$$

$$\text{and } t = u_{\text{vert}} / g$$

As the time in the air is twice this, the expression is: $t = 2u_{\text{vert}} / g$

The range is given by the time in the air multiplied by the horizontal velocity:

$$\text{range, } r = 2u_{\text{vert}} / g \times u_{\text{hor}} = 2u_{\text{vert}} u_{\text{hor}} / g$$

If the initial velocity is given in the form of a velocity at an angle θ above the horizontal, the three equations can be given as:

$$\text{maximum height, } s = (v \sin \theta)^2 / 2g$$

$$\text{time in air, } t = 2v \sin \theta / g$$

$$\text{range, } r = 2v^2 \sin \theta \cos \theta / g$$

The trajectory shown in Figure 3.22 is symmetrical. The angle with the ground at which the projectile starts its motion is the same as the angle just before the projectile hits the ground, and the magnitude of the vertical component of the initial velocity is the same as the vertical component of the velocity just before the projectile hits the ground.

Activity 3.13

A monkey is hanging from a branch of a tree. A hunter aims a rifle at the monkey and fires.

At the instant the rifle fires, the monkey lets go of the branch and begins to fall.

What happens? Use the equations of motion to find out.

What assumptions do you make?

Uniform circular motion

When an object is moving in a circle, there are two ways we can describe how fast it is moving. We can give its speed as it moves around the circle, or we can say that it is going round the circle at a certain number of revolutions per minute.

Radian measure for angles

For all practical work, we would measure angles in degrees. For theoretical work, such as this topic on circular motion, it is often far more convenient to measure angles in radians. A radian is a larger angle than a degree – it is just over 57° . Where does it come from?

Radians are derived directly from circles. An angle of 1 radian provides a sector of a circle of radius r such that the length around the arc of the circle is also r , as shown in Figure 3.23.

Since the circumference of a circle is $2\pi r$, you can fit 2π radians into a complete turn. As a complete turn is also 360° , we can see that:

$$2\pi \text{ radians} = 360^\circ$$

$$\text{and } 1 \text{ radian} = 360^\circ/2\pi = 57.3^\circ$$

Radian measure provides a quick and easy way to work out distances measure round the rim of a sector (Figure 3.24).

When θ is 1 radian, $s = r$. When $\theta = 2$ radians, $s = 2r$. In general, $s = \theta r$.

Angular velocity is given the symbol ω (small omega in the Greek alphabet). In this work we will consider it to be measured not in complete revolutions per minute but in radians per second (rad/s).

There is a connection between the speed v of a body as it goes round a circle of radius r and its angular velocity ω in rad/s.

In time t , the distance travelled round the circle by the body will be vt . The angle traced out will be ωt . We know that $s = \theta r$, so $s = \omega t r$.

We also know that $s = vt$, so

$$vt = \omega t r$$

Cancelling the t s gives us:

$$v = \omega r$$

Acceleration is defined as the rate of change of velocity. We can find it by dividing the change in velocity by the time taken. Let us apply that to a body moving in a circle of radius r . Its linear speed (a scalar) is v and its angular velocity is ω .

Figure 3.25 shows the body in two positions separated by a small time t . The angle covered in that time will be ω . The original velocity is v_1 , the later velocity is v_2 (same speed, different direction).

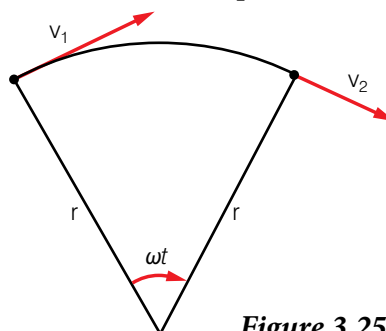

Figure 3.25

KEY WORDS

uniform circular motion

when a body is moving at a constant speed in a circle

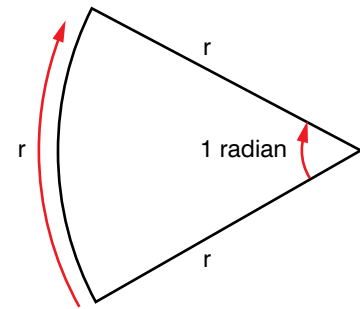

Figure 3.23 The sector of a circle that is formed by an angle of 1 radian

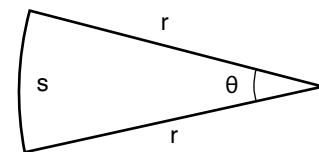

Figure 3.24 Sector of a circle with angle θ

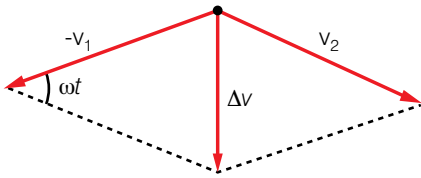

Figure 3.26

By how much has the velocity changed over time t ? We need to find Δv , given by $v_2 - v_1$. These are vectors, so we need to consider their directions when working this out. Remember that $-v_1$ has the same magnitude as v_1 , but is in the opposite direction. We know how to add and subtract vectors from Unit 2 – we can draw a parallelogram, as shown in Figure 3.26.

The first thing to notice is that the direction of Δv , and therefore of the acceleration, is directly towards the centre of the circle.

What is the magnitude of Δv ? This needs a bit more thought. Consider the triangle that makes up the left-hand part of the parallelogram. The body had turned through an angle of ωt , so that is the angle between v_1 and v_2 , and is marked on Figure 3.26.

This is a moment when radian measure helps us. We have an angle ωt in radians, and the sector of the circle has a radius v which is the speed. (It is true that Δv is a straight line and not an arc of a circle, but time t is a very short interval in which case the difference vanishes.)

In terms of magnitudes $s = \theta r$ gives us:

$$\Delta v = \omega t v$$

Acceleration is given by $\Delta v/t$, the acceleration a will be:

$$a = \Delta v/t = \omega t v/t = \omega v$$

But $v = \omega r$, so we can express the acceleration as:

$$a = \omega^2 r = v^2/r \text{ towards the centre of the circle.}$$

Worked example 3.10

A boy is riding a bicycle at a velocity of 4 m/s. The bicycle's wheels have a diameter of 0.8 m.

- What is the velocity of a point on the rim of the wheel? (Ignore the effects of the forward motion of the bicycle)
 - What is the angular velocity of the wheel?
 - What is the acceleration of a point on the rim of the wheel? In what direction is it acting?
- a) First draw a diagram to show the wheel.

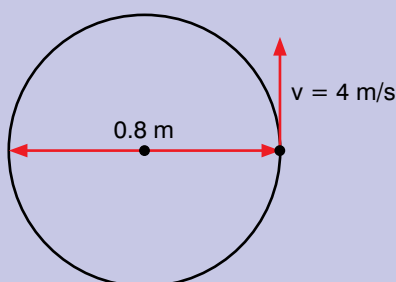

Figure 2.27

The bicycle is travelling at 4 m/s, so in 1 second a point on the rim of the wheel will travel 4 m.

The linear velocity of a point on the rim of the wheel is 4 m/s.

- b) We need to use the equation $v = \omega r$

$$v = 4 \text{ m/s and } r = 0.8 \div 2 = 0.4 \text{ m}$$

Substituting the values into the equation:

$$\omega = v/r = 4 \text{ m/s} \div 0.4 \text{ m} = 10 \text{ rad/s}$$

- c) acceleration = $\omega^2 r$

$$= (10 \text{ rad/s})^2 \times 0.4 \text{ m} = 40 \text{ m/s}^2$$

The direction is towards the centre of the wheel.

We could also use the equation
acceleration = v^2/r

$$v = 4 \text{ m/s, } r = 0.4 \text{ m}$$

$$\text{acceleration} = (4 \text{ m/s})^2 \div 0.4 \text{ m} = 40 \text{ m/s}^2$$

Newton's first law of motion tells us that if no resultant force acts on a moving body, the body will just keep moving at the same speed in the same direction.

When an object is moving in a circle, its direction is constantly changing. We have just shown that there is an acceleration towards the centre of the circle. We can also say that there must be a resultant (unbalanced) force on the object which acts inwards towards the centre of the circle.

This is known as a **radial force**.

Figure 3.29 When an object is moving in a circle, there is a radial force towards the centre of the circle that changes direction constantly, while the magnitude of the velocity stays the same.

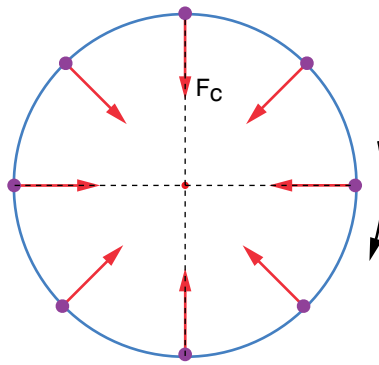

When a car is going round a bend (Figure 3.30), that force must be due to friction between the tyres and the ground: if the road is slippery with spilt oil, such a frictional force may not be available, in which case the car will continue at a steady speed in a straight line!

Worked example 3.11

A bus of mass 2500 kg goes round a corner of radius 50 m at a speed of 5 m/s.

What force is needed for the bus to go round the corner?

$$\begin{aligned} \text{Acceleration} &= v^2/r \\ v &= 5 \text{ m/s and } r = 50 \text{ m} \\ \text{So } a &= 5^2/50 \\ &= 25/50 = 0.5 \text{ m/s}^2 \end{aligned}$$

$$\begin{aligned} \text{Force} &= \text{mass} \times \text{acceleration} \\ &= 2500 \times 0.5 \\ &= 1250 \text{ N} \end{aligned}$$

Motion in a vertical circle

When a body is moving in a horizontal circle, the magnitude of the velocity (or the speed) stays constant. However, when a body moves in a vertical circle, the speed does not stay constant – it decreases as the body moves towards the top of the circle and increases as it moves towards the bottom of the circle.

Figure 3.31 overleaf shows the forces acting on a body moving in a vertical circle. There is **centripetal force** towards the centre of the circle and the force due to gravity, which is always downwards. At the top of the circle, the forces are acting in the same direction, and

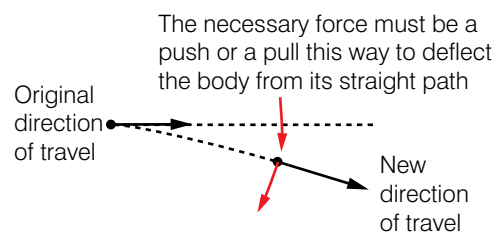

Figure 3.28 There must be a force that is pulling or pushing the body into a circular path

KEY WORDS

radial force the force acting on a body moving in a circle which is directed towards the centre of the circle.

tangential acceleration when a particle is moving in circular motion, the component of a particle's acceleration at a tangent to the circle

radial acceleration acceleration towards the centre of the circle when a particle is moving in a circle

centripetal force the force acting on a body moving in a circle which is directed towards the centre of the circle



Figure 3.30 There is a force on this racing car that enables it to go round the bend

at the bottom they are acting in opposite directions. Halfway up the circle, the two forces are acting at right angles (Figure 3.31).

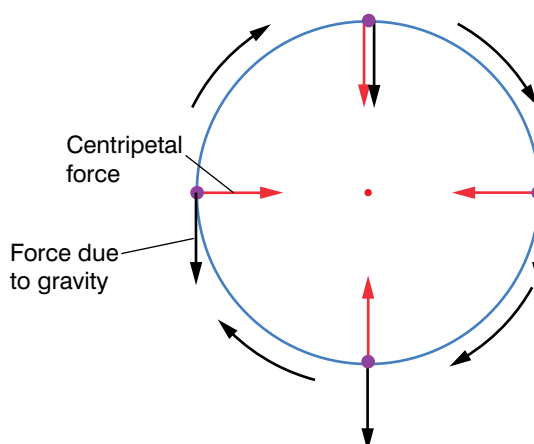

Figure 3.31 Free body diagram for a body moving in a circle

A pendulum moves in an arc of a vertical circle. Its speed is not high enough for it to move round a complete circle, so it oscillates about the bottom of the circle. The period (time for one complete swing backwards and forwards) of a pendulum is given by $T = 2\pi\sqrt{l/g}$ where l is the length of the pendulum.

This equation is only true for small angles of swing (less than 1 radian).

Activity 3.14

You are going to use a simple pendulum to find a value for g .

- Set up the pendulum as shown in Figure 3.32.

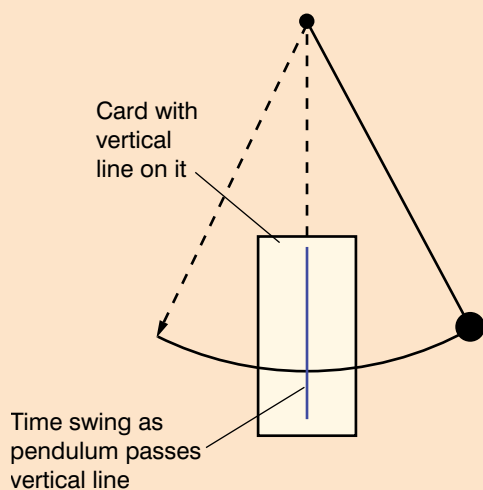

Figure 3.32 Pendulum

- Investigate how the period of the pendulum varies for different lengths of the pendulum.
- Plot a graph of T^2 against l .
- Find the gradient of the graph – this will be equal to $4\pi^2/g$.
- From this find a value for g . How does this compare with the actual value of g ?
- Write a report describing how you carried out your experiment, including what you did to make sure your test was fair, and details of your experimental results. Use the writing frame on pages 19–20 for the structure of your report.

Worked example 3.12

A girl is swinging a bucket on a piece of rope in a vertical circle with a radius of 1 m. What is the minimum speed needed at the top of the circle so that the bucket stays moving in the circle.

At the top of the circle, the forces acting on the bucket are the force due to gravity and the centripetal force, F , which is the tensile force provided by the string.

We also know that force = mass \times acceleration
The acceleration of the bucket is $\frac{v^2}{r}$.

Draw a diagram to show the forces.

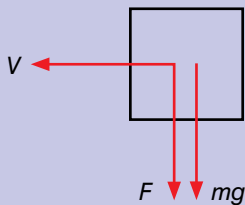

Figure 3.33 Free-body diagram showing forces acting on bucket at the top of the circle.

At the top of the circle:
 $F + mg = \frac{mv^2}{r}$

At the point that the bucket stops moving in a circle, $F = 0$, and $v_y = 0$ so
 $mg = \frac{mv^2}{r}$
 $v^2 = rg$
 $v = \sqrt{rg}$

We know that the radius is 1 m and
 $g = 9.8 \text{ m/s}^2$, so
 $v = \sqrt{(1 \times 9.8)} = 3.1 \text{ m/s}$

Worked example 3.13

An object is moving in a vertical circle attached to a piece of rope which is anchored in the centre of the circle. The circle has a radius of 1 m and the object is moving at a steady speed of 5 m/s. The mass of the object is 3 kg. Assume the rope to be massless.

Work out the tension in the rope at the bottom, top and halfway between the bottom and top of the circle.

First draw a free-body diagram to show the forces acting on the object and water.

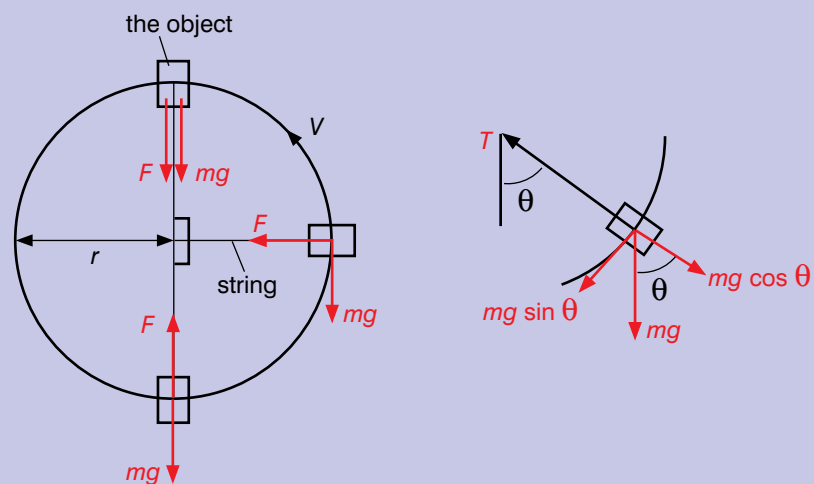

Figure 3.34

The net force to the centre is given by the tension in the rope minus the component of the weight of the object and water that is acting in the same line as the centripetal force, which is the tensile force provided by the rope:

$$F = T - mg \cos \theta$$

$$\text{Now we know that } F = \frac{mv^2}{r}$$

So the tension in the rope is given by

$$T = \frac{mv^2}{r} + mg \cos \theta$$

We know the following values:

$$r = 1 \text{ m}, v = 5 \text{ m/s} \text{ and } m = 3 \text{ kg}$$

At the bottom of the circle, $\theta = 0 \text{ rad}$, so:

$$\begin{aligned} T &= \frac{3 \text{ kg} \times (5 \text{ m/s})^2}{1 \text{ m}} + 3 \text{ kg} \times 9.8 \text{ m/s}^2 \times \cos 0 \\ &= 75 + 29.4 = 104.4 \text{ N} \end{aligned}$$

At the top of the circle, $\theta = \pi$, so

$$\begin{aligned} T &= \frac{3 \text{ kg} \times (5 \text{ m/s})^2}{1 \text{ m}} + 3 \text{ kg} \times 9.8 \text{ m/s}^2 \times \cos \pi \\ &= 75 - 29.4 = 45.6 \text{ N} \end{aligned}$$

Halfway between bottom and top, $\theta = \pi/2$, so

$$\begin{aligned} T &= \frac{3 \text{ kg} \times (5 \text{ m/s})^2}{1 \text{ m}} + 3 \text{ kg} \times 9.8 \text{ m/s}^2 \times \cos \pi/2 \\ &= 75 - 0 = 75 \text{ N} \end{aligned}$$



Figure 3.35 The force of gravity keeps the International Space Station in its orbit of the Earth.

DID YOU KNOW?

Electrical forces are larger than gravitational forces by a factor of 10^{39} times!

Discussion activity

Satellites are all launched from sites as close to the equator as possible. Why do you think this is?

Motion of a satellite

You should remember from work you did in Grade 10 that when two masses M_1 and M_2 are a distance r apart, there is a gravitational force between them which is given by

$$F = \frac{GM_1M_2}{r^2}$$

where G is the gravitational constant and is equal to $6.67 \times 10^{-11} \text{ N m}^2 \text{ kg}^{-2}$

This is known as Newton's law of universal gravitation. Gravitation is solely an attractive force and is very small. Gravity is the force that keeps the Earth in its orbit of the Sun, the Moon in its orbit of the Earth and the International Space Station in its orbit of the Earth.

Worked example 3.14

The Hubble Space Telescope is in orbit 559 km above the surface of the Earth.

- What is its angular velocity?
- How long does it take to complete an orbit of the earth?

The radius of the Earth is about 6400 km. The mass of the Earth is $5.97 \times 10^{24} \text{ kg}$.

- The radius of the orbit of the telescope is $559 + 6400 = 6959 \text{ km} = 6.959 \times 10^3 \text{ m}$

The gravitational force using Newton's law of gravitation is:

$$F = \frac{GM_1M_2}{r^2}$$

As this telescope is in orbit, this is also equal to $F = M_2\omega^2r$ where M_2 is the mass of the telescope.

So

$$M_2\omega^2r = \frac{GM_1M_2}{r^2}$$

$$\omega^2 = \frac{GM_1}{r^3}$$

$$= (6.67 \times 10^{-11} \text{ N m}^2 \text{ kg}^{-2} \times 5.97 \times 10^{24} \text{ kg}) / (6.959 \times 10^3 \text{ km})^3$$

$$= 1.182 \times 10^{-6}$$

$$\omega = \sqrt{1.182 \times 10^{-6}} = 1.087 \times 10^{-3} \text{ rad/s}$$

- Time taken for one orbit = $2\pi/\omega$
 $= 2\pi / 1.087 \times 10^{-3}$
 $= 5780 \text{ seconds}$
 $= 96.33 \text{ minutes}$

Relative velocity

When the velocity of a certain body is given, the value of this velocity is given as noted by an observer. When an observer who is stationary records some velocity, then the velocity is referred to as **absolute velocity**, or simply velocity. On the other hand, any velocity of a body noted by a non-stationary observer is more correctly termed **relative velocity**; that is, it is the velocity if the body relative to the moving observer. For example, if one bus is overtaking another, a passenger in the first bus sees the overtaking bus as moving with a very small relative velocity. But if the passenger was in a stationary bus, then the overtaking bus would be seen to be moving much more quickly.

If the observer is not stationary, then to find the velocity of body B relative to body A, subtract the velocity of body A from the velocity of body B. If the velocity of A is v_A and that of B is v_B , then the velocity of B with respect to A is:

$$\text{relative velocity } v_{BA} = v_B - v_A$$

Worked example 3.15

Nishan is running eastwards at a speed of 10 km/h and at the same time Melesse is running northwards at a speed of 9 km/h. What is the velocity of Nishan relative to Melesse?

We will use the standard frame of reference – velocities to the East are positive, as are velocities to the North.

In vector form, the velocities are:

$$v_A = \begin{bmatrix} 10 \text{ km/h} \\ 0 \text{ km/h} \end{bmatrix}$$

$$v_B = \begin{bmatrix} 0 \text{ km/h} \\ 9 \text{ km/h} \end{bmatrix}$$

Calculate their relative velocity:

$$\text{Relative velocity } v_{AB} = v_A - v_B = \begin{bmatrix} 10 - 0 \\ 0 - 9 \end{bmatrix} = \begin{bmatrix} 10 \\ -9 \end{bmatrix} \text{ km/h}$$

The magnitude is $\sqrt{(100 + 81)} = 13.45 \text{ km/h}$

The direction is $\tan^{-1}(-9/10) = -42^\circ$

The direction is -42° to the east.

So Nishan is moving at 13.45 km/h at an angle of -42° to the east, relative to Melesse. Melesse is moving at 13.45 km/h at an angle of 42° to the east, relative to Nishan.

KEY WORDS

absolute velocity *velocity observed from a stationary frame of reference*

relative velocity *the vector difference between the velocities of two objects*

Activity 3.15

Student A and student B walk at normal walking speed across the classroom, at right angles to each other.

- What is the velocity of the two students walking at from the point of view of the rest of the class?
- What is the velocity of student A from the point of view of student B?
- What is the velocity of student B from the point of view of student A?

Summary

In this section you have learnt that:

- To describe motion using vectors.
- To analyse, predict and explain the motion of a projectile.
- To analyse, predict and explain uniform circular motion in the horizontal and vertical planes.
- To describe and apply Newton's law of universal gravitation.
- To use Newton's law of universal gravitation to explain the motion of the planets and satellites.
- That in circular motion there is a constant force towards the centre of the circle.

Review questions

Take g to be 9.8 m/s^2 and ignore air resistance in questions 1–5.

1. An aircraft flying at a steady velocity of 70 m/s eastwards at a height of 800 m drops a package of supplies.
 - a) Express the initial velocity of the package as a vector. What assumptions have you made about the frame of reference?
 - b) How long will it take for the package to reach the ground?
 - c) How fast will it be going as it lands? Express your answer as a vector.
 - d) Describe the path of the package as seen by a stationary observer on the ground.
 - e) Describe the path of the package as seen by someone in the aeroplane.
2. A stone is thrown upwards with an initial velocity of 25 m/s at an angle of 30° to the ground.
 - a) Show that the vertical component of the velocity at the start is 12.5 m/s upwards.
 - b) Without doing any calculations, state what the stone's vertical velocity will be when it again reaches ground level.
 - c) Using the answer to a), show that the stone will rise to a height of about 8 m .
 - d) How long will it take for the stone to reach its maximum height?
 - e) How long will it take between when the stone was thrown and when it comes back to the ground?
 - f) Explain why the horizontal component of the stone's velocity at the start is 21.7 m/s .
 - g) What will the stone's horizontal velocity be just before it lands?
 - h) Use the answers to parts e)–g) to work out the stone's horizontal range.

3. Ebo throws a ball into the air. Its velocity at the start is 18 m/s at an angle of 37° to the ground.
 - a) Express the initial velocity in component vector form.
 - b) Work out the velocity of the ball as it lands. Give your answer in component vector form.
 - c) Work out the range of the ball.
 - d) What assumptions have been made about the frame of reference?
4. Ebo throws the ball again at an initial velocity of 18 m/s but this time at an angle of 53° to the ground.
 - a) Work out the velocity in component vector form.
 - b) Why will the ball spend a longer time in the air than it did before.
 - c) Calculate the range of the ball.
5. Look at the equations for maximum height, time of flight and range. Check the dimensions of each of these, by putting them into the equations.
6. A mass on the end of a length of rope is being swung in a circle of radius 3.2 m at an angular velocity of 0.71 rad/s. How fast is it moving?
7. A spinning top has a diameter of 10 cm. A point on the outer rim of the top moves through an angle of 8π radians each second.
 - a) What is the angular velocity of the point?
 - b) What is the distance moved by the point in 5 seconds?
 - c) What is the velocity of the point?
 - d) What is the acceleration of the point?
8. A car of mass 800 kg goes round a corner of radius 65 m at a speed of 10 m/s.
 - a) What size force is needed to achieve this?
 - b) Suggest how this force is likely to be obtained.
 - c) What force would be needed if the driver approached the bend at twice the speed?
9. A fishing line will break when the tension in it reaches 15 N. A 3.1 m length of it is used to tie a model aeroplane of mass 280 g to a post so it goes round in circles. What is the fastest speed the aeroplane can reach before the line breaks.

Give your answer both as an angular velocity and in m/s.
10. A centrifuge consists of a container held at a distance of 0.20 m from its axis. When turned on, the centrifuge spins the container and its contents round at 9000 revolutions per minute.
 - a) Find its angular velocity.
 - b) A small mass of 10 g is placed in the drum. Work out what force will need to be provided for it to go round at that rate in a circle of radius 0.20 m.

- c) In which direction must that force act?
d) What supplies that force to the ball?
e) Taking g to be 9.8 N/kg , what size force will the Earth supply to the ball when it is at rest on the floor?
11. A toy car moves around a loop-the-loop track. The loop is 0.5 m high. What is the minimum speed of the car at the top of the loop for it to stay on the track?
12. A boy is swinging a toy on a piece of string in a vertical circle. The toy has a mass of 150 g and the radius of the circle is 0.8 m .
- a) He swings the toy with a linear velocity of 2 m/s . Will the toy move in a circle? Explain your answer.
b) Another boy swings the toy with a linear velocity of 3.5 m/s .
Work out the tension in the string at the top of the circle, at the bottom of the circle and halfway between the top and the bottom of the circle.
13. A geostationary satellite for communications seems to be in a fixed spot above the equator because it has the same angular velocity as the earth.
- a) Show that if it goes round once a day, its angular velocity ω is a little over $7 \times 10^{-5} \text{ rad/s}$.
b) Geostationary satellites are placed in orbits of radius $4.2 \times 10^4 \text{ m}$. Use this information to deduce g , the acceleration of a freely falling body, at this height.
14. At ground level g is 9.8 m/s^2 . Suppose the Earth started to increase its angular velocity. How long would a day be when people on the equator were just 'thrown off'? Why is the expression 'thrown off' a bad one?
15. Two cars A and B are moving along a straight road in the same direction with velocities of 25 km/h and 30 km/h , respectively. Find the velocity of car B relative to car A.
16. Two aircraft P and Q are flying at the same speed, 300 m s^{-1} . The direction along which P is flying is at right angles to the direction along which Q is flying.
- a) Find the magnitude of the velocity of the aircraft P relative to aircraft Q.
b) Find the direction of the velocity.
17. A river flows at 2 m/s . The velocity of a ferry relative to the shore is 4 m/s at right angles to the current. What is the velocity of the ferry relative to the current?

End of unit questions

1. Construct a glossary of the key terms in this unit. You could add it to the one you made for Units 1 and 2.
2. Describe what happens to a ball when you drop it from a height of 2 metres.
3. Explain the difference between average velocity and instantaneous velocity.
4. A bus travels 80 km due south in 2 hours. It then travels 100 km due west in 3 hours. What is the average velocity of the bus?
5. A car is travelling at 50 km/h. The driver sees a child run out into the road 5 m ahead. She applies the breaks and the car stops in 5 seconds. The driver's thinking time is 1.5 s.
 - a) Will the car stop in time?
 - b) If the driver's thinking time is increased to 2.5 s, will the car stop in time?
 - c) What happens if the thinking time is 1.5 s but the car is travelling at 64 km/h?
6. What assumption do you have to make if you are asked to do a calculation on a falling body?
7. A boy walks to school. He walks 3 km in 30 minutes. He meets some friends and they talk for 10 minutes before they carry on walking to school. They walk 1 km in 15 minutes.
 - a) Draw a displacement–time graph to show the boy's journey to school.
 - b) What was the average velocity of the boy's journey? Give your answer in m/s.
8. Explain, in terms of forces and acceleration, what happens when a body is moving in uniform horizontal circular motion.
9. How do the forces on a body moving in a vertical circle vary?
10. What is the difference between radial and tangential acceleration?
11. What is relative velocity?

Contents	
Section	Learning competencies
4.1 The force concept (page 67)	<ul style="list-style-type: none"> Identify the four basic forces in nature. Define and describe the concepts and units related to force.
4.2 Basic laws of dynamics (page 69)	<ul style="list-style-type: none"> Define the term dynamics. Define and describe the concepts and units related to coefficients of friction. Use the laws of dynamics in solving problems. Interpret Newton's laws and apply these to moving objects. Explain the conditions associated with the movement of objects at constant velocity. Solve dynamics problems involving friction. State Newton's universal law of gravitation. Analyse, in qualitative and quantitative terms, the various forces acting on an object in a variety of situations, and describe the resulting motion of the object.
4.3 Law of conservation of linear momentum and its applications (page 75)	<ul style="list-style-type: none"> Define, and when appropriate give examples of, such concepts as gravity and Newton's law of universal gravitation. Describe how Newton's laws of motion and his law of universal gravitation explain the phenomenon of gravity and necessary conditions of 'weightlessness'. Describe the terms momentum and impulse. State the law of conservation of linear momentum. Discover the relationship between impulse and momentum, according to Newton's second law. Apply quantitatively the law of conservation of linear momentum.
4.4 Elastic and inelastic collisions in one and two dimensions (page 82)	<ul style="list-style-type: none"> Distinguish between elastic and inelastic collisions. Describe head-on collisions. Describe glancing collisions.
4.5 Centre of mass (page 85)	<ul style="list-style-type: none"> Define and describe the concepts and units related to torque. Describe centre of mass of a body. Determine the position of centre of mass of a body.
4.6 Momentum conservation in a variable mass system (page 90)	<ul style="list-style-type: none"> Describe explosions and rocket propulsion in relation to momentum conservation.
4.7 Dynamics of uniform circular motion (page 92)	<ul style="list-style-type: none"> Interpret Newton's laws and apply these to objects undergoing uniform circular motion. Solve dynamics problems involving friction.

You have already come across many of the concepts covered in this unit. The concepts will be extended using what you learned about vectors in Unit 2. You covered kinematics in the last unit, which is describing motion. In this unit you will be considering dynamics, which looks at the causes of motion. Dynamics is applied in every branch of physics.

4.1 The force concept

By the end of this section you should be able to:

- Identify the four basic forces in nature.
- Define and describe the concepts and units related to force.

You should know from your earlier studies that a force is something that can change the speed and direction of movement of a body as well as changing the shape of a body. A force can act in any direction, which means that force is a vector.

There are four basic forces in nature:

- gravity: purely attractive force, which can act over long distances
- electromagnetism: attractive and repulsive force, which acts on charged particles
- weak nuclear force: acts on the scale of the atomic nucleus
- strong nuclear force: stronger than the electromagnetic force on the scale of the atomic nucleus – keeps protons and neutrons bound together in the nucleus.

In Unit 2 we looked at adding forces together. Forces can act in all directions. Sometimes we want to resolve a force into components that are perpendicular to each other. These components usually are aligned to the components of the frame of reference we use. The components are usually horizontal and vertical vectors. We know from adding vectors together that the combination of these two forces has the same effect.

Figure 4.1 shows an example of where resolving the forces can be useful. The man is pulling a heavy load using a rope. The rope provides the force needed to move the load along the ground. The rope is at an angle to the horizontal, so the force it provides has a horizontal component and a vertical component.

It is only the horizontal component of the force that causes the load to move. (The vertical component tends to lift the load upwards.) This tells us that the man's force would have more effect if he pulled horizontally; the steeper the angle of the rope the less effective he will be, because the horizontal component will be smaller.

Discussion activity

Discuss what distances the four forces act over.

What effect do they have on our surroundings?

Draw up a table to summarise the results of your discussion.

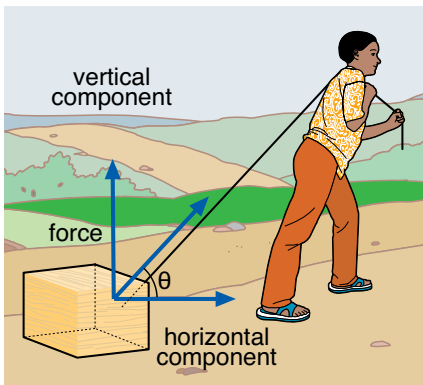

Figure 4.1 The force pulling the load is at an angle to the horizontal. It is the horizontal component of the force that causes the load to move along the ground.



Figure 4.2 Crossing this river is tricky when the river is flowing fast

You can work out the horizontal and vertical components of the force by resolving the force into its horizontal and vertical components. If the force used is F , then

$$\text{vertical component, } F_y = F \sin \theta$$

$$\text{horizontal component, } F_x = F \cos \theta$$

Look at Figure 4.2. The man is pulling a load across the fast-flowing river. The river pushes the raft downstream. To make the raft go straight across, the man has to pull at an angle. One component of his pulling force is needed to counteract the force of the moving water. The other component, at right angles to the riverbank, makes the raft move across to the other side.

Worked example 4.1

A man is pulling a string, which is attached to a box. The string is at an angle of 40° to the horizontal. The force applied to the box is 50 N.

What is the force needed to move the box?

First draw a diagram to show the force and its direction (Figure 4.3).

The component of the force that causes the box to move is the horizontal component.

Using trigonometry

$$\text{horizontal component} = 50 \cos 40^\circ = 38.3 \text{ N}$$

It takes 38.3 N to move the box.

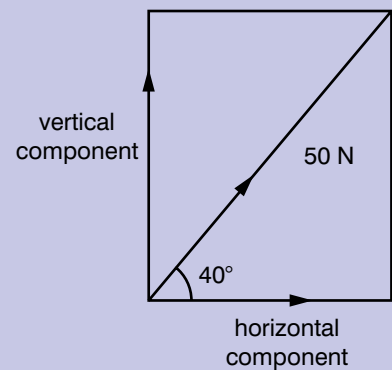

Figure 4.3

Summary

In this section you have learnt that:

- A force can change the speed and direction of a body.
- Force is a vector.
- A force can be resolved into horizontal and vertical components.

Review questions

- Look at Figure 4.1. The man is using a force of 110 N to pull the box. He is pulling at an angle of 50° to the horizontal.
What is the force needed to move the box?
- Look at Figure 4.2. The man is pulling on the rope with a force of 175 N. He is pulling at an angle of 40° to the flow of the river.
 - Draw a diagram to show the directions of the forces.
 - What is the force he is exerting to move the raft across the river?

Activity 4.1

- Attach a length of string to a box on the floor. Attach a newtonmeter to the end of the string.
- Hold the string at an angle to the ground and measure the angle.
- Pull the box until it moves – record the force needed to make the box move.
- Repeat for the string held at different angles.
- Work out the horizontal component of the force for each attempt to move the box. What do you notice?

4.2 Basic laws of dynamics

By the end of this section you should be able to:

- Define, and when appropriate give examples of, such concepts as gravity and Newton's law of universal gravitation.
- Describe how Newton's laws of motion and his law of universal gravitation explain the phenomenon of gravity and necessary conditions of 'weightlessness'.
- Define the term dynamics.
- Define and describe the concepts and units related to coefficients of friction.
- Use the laws of dynamics in solving problems.
- Interpret Newton's laws and apply these to moving objects.
- Explain the conditions associated with the movement of objects at constant velocity.
- Solve dynamics problems involving friction.
- State Newton's universal law of gravitation.
- Analyse, in qualitative and quantitative terms, the various forces acting on an object in a variety of situations, and describe the resulting motion of the object.

KEY WORDS

dynamics *the study of what causes objects to move*

Recap of Newton's laws of motion

In Grade 9, you learned about the basic laws of **dynamics**. Newton's three laws of motion are at the centre of this. They are:

- First law: a body will continue in its state of rest or uniform motion unless a force acts on it.
- Second law: when a force acts on a body, the body is accelerated by this force according to the relationship $F = ma$ where F is the force acting on the body, m is the mass of the body and a is the acceleration of the body.

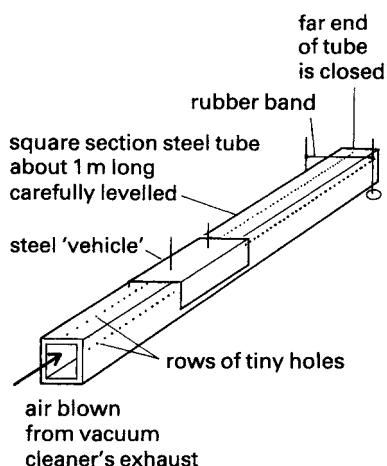

Figure 4.4 An air track can be used to demonstrate Newton's laws of motion.

Discussion activity

What other ways of demonstrating Newton's laws can you think of that use the trolleys shown in Figure 4.5?

Discussion activity

Consider the two students in Figure 4.5. Consider the forces exerted by each student as vectors.

- What do they add up to?
- What about the accelerations?

- Third law: when a body exerts a force on a second body, the second body exerts a force which is equal in size but in the opposite direction to the force exerted by the first body.

Newton's third law can also be expressed as: 'for every action there is an equal and opposite reaction'.

Demonstration of Newton's laws

We can demonstrate Newton's laws using an air track, as shown in Figure 4.4. The air track reduces friction by keeping the 'vehicle' clear of the tube from the air blowing out of the holes in the tube. The 'vehicle' is supported like a hovercraft.

If we push the vehicle and let go, it will keep going because there is no friction to slow it down. If the rubber band was not there to stop it, it would carry on at the same speed.

We can also demonstrate Newton's third law. Two students stand on wheeled trolleys, as shown in Figure 4.5. One student pushes on the other. What happens? Both students move, but in opposite directions. This shows that as the first student exerts a force on the second one, the second student is exerting a force on the first one which is equal in size and opposite in direction.

When the students start moving, their acceleration is determined by Newton's second law.

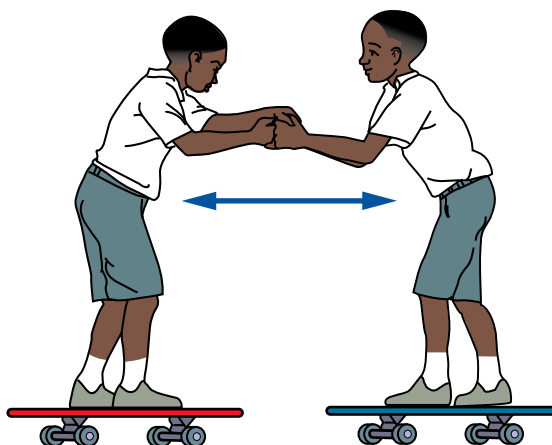

Figure 4.5 What will happen when one student pushes on the other?

Newton's second law

As force is a vector – it has direction – then the acceleration produced by it will also have a direction and will also be a vector. Mass does not have a direction – it is a scalar. The acceleration will be in the same direction as the force because mass is positive and cannot be negative.

The right-hand side of the equation $F = ma$ is a vector multiplied by a scalar, which you came across in Unit 2.

Worked example 4.2

Look at Figure 4.6. The mass of the lorry is 10 tonnes. What will happen to the lorry?

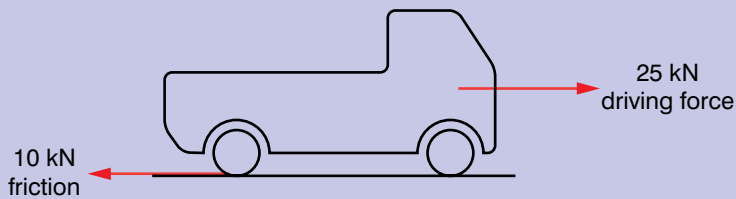
**Figure 4.6**

Consider the horizontal and vertical forces.

Assume that the positive horizontal direction is to the right, and the positive vertical direction is upwards.

There is a force downwards, which is the weight of the lorry, which is balanced by an upwards force from the road, so the net vertical force (F_y) is zero.

There are two horizontal forces acting on the lorry: a driving force acting to the right, +25 kN, and a friction force, acting to the left, -10 kN.

So the net force, $F_x = 25 \text{ kN} - 10 \text{ kN} = 15 \text{ kN}$

There is a net force to the right (positive x-direction), which will produce an acceleration to the right.

So we need to use Newton's second law $F = ma$, but the net force only acts in the x-direction.

$$a_x = F_x/m = 15 \text{ kN}/10\,000 \text{ kg} = 1.5 \text{ m/s}^2$$

(Remember that the mass of the truck needs to be converted to kilograms.)

The truck will accelerate to the right at 1.5 m/s^2 .

Worked example 4.3

A ball of mass 0.5 kg is held on a slope of 20° to the horizontal. The ball is let go. What will the acceleration of the ball be?

First draw a diagram (Figure 4.7). We need to find the component of the weight of the ball that is acting down the slope – this will be the force that is accelerating the ball.

From the diagram we can see the component of the force that is parallel to the slope is $mg \sin 20^\circ$

$$F = ma$$

$$\text{so } ma = mg \sin 20^\circ$$

$$a = g \sin 20^\circ$$

$$= 9.8 \times 0.342 = 3.35 \text{ m/s}^2 \text{ at an angle of } 20^\circ \text{ below the horizontal.}$$

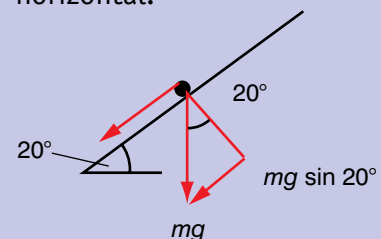
**Figure 4.7**

The ball is let go and it rolls down the slope.

Friction

Friction is the force that stops us from slipping when we walk. There are two types of friction: static friction and kinetic friction. **Static friction** is the friction between two surfaces when there is no movement. For example, when a car is not moving, the static friction between the tyres and road stops the car from sliding.

Kinetic friction is the friction between two surfaces when one of them is sliding over the other. For example, when you push a box along the floor, there is kinetic friction between the box and the floor when the box is moving.

Static friction

Imagine that you try to push a box along a table. With a small force, the box will not move. The force you apply is equal to the frictional force – if it was not, the box would move.

KEY WORDS

kinetic friction the frictional force between two objects sliding over each other

static friction the frictional force between two objects that are trying to move against each other but are not yet moving

KEY WORDS

limiting friction *the maximum value of static friction*

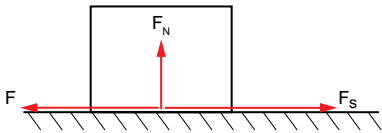

Figure 4.8 Static friction

As you increase the force, you will reach a point where the box will begin to move – the frictional force reaches a maximum value. At this maximum value, the friction is said to be **limiting**. If the box does not move and the friction is limiting, the box is in limiting equilibrium.

When the frictional force is at the maximum, the box will either be moving or on the verge of moving.

The coefficient of static friction is a number between 0 and 1, which represents the friction between two surfaces. The maximum frictional force (in limiting equilibrium) is:

$$F_s = \mu_s F_N$$

where F_s is the frictional force, μ_s is the coefficient of static friction and F_N is the normal force between the two objects, as shown in Figure 4.8.

Activity 4.2

You are going to find the coefficient of static friction between two surfaces – a box and a ramp.

- Measure the weight of the box.
- Put the box on the ramp. Tilt the ramp slowly until the box slides. Record the angle of the ramp.
- Repeat twice.
- Repeat for other materials.
- Work out the coefficient of friction between the surfaces.

Worked example 4.4

A box that weighs 60 N is on a ramp, which is inclined at 30° to the horizontal (Figure 4.9).

The box is in limiting equilibrium. Find the coefficient of friction between the box and the plane.

We need to resolve the weight of the box into components that are parallel and perpendicular to the plane, as shown in Figure 4.10.

The normal force is:

$$F_N = 60 \cos 30^\circ$$

In limiting equilibrium, the frictional force up the slope and the force down the slope are equal and opposite and we know that $F_s = \mu_s F_N$, so:

$$\mu_s F_N = 60 \sin 30^\circ$$

Substituting for F_N :

$$\mu_s 60 \cos 30^\circ = 60 \sin 30^\circ$$

$$\begin{aligned} \mu_s &= \sin 30^\circ / \cos 30^\circ \\ &= 0.5 / 0.866 = 0.58 \end{aligned}$$

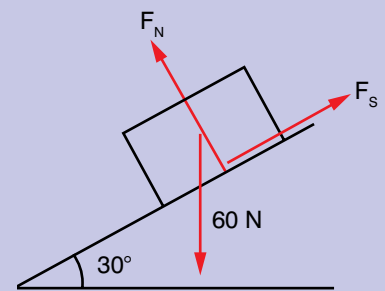

Figure 4.9

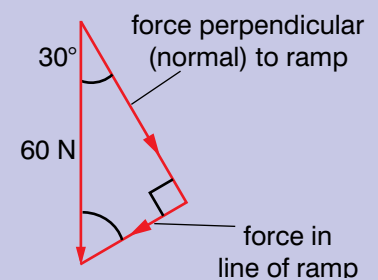

Figure 4.10 Components of weight of box parallel and normal to the ramp

Project work

Prepare a presentation on the importance of friction in everyday life. Where do we try to maximise friction and where do we try to minimise it?

Kinetic friction

The coefficient of kinetic friction is a number between 0 and 1, which represents the friction between two surfaces. The frictional force is:

$$F_k = \mu_k F_N$$

You should have found that static friction is greater than kinetic friction.

Activity 4.3

You are going to find the coefficient of kinetic friction between two surfaces – a box and a table.

- Measure the weight of the box, as you did in Activity 4.2.
- Put the box on the table. Pull the box along the table at a steady speed, as shown in Figure 4.11. Record the force needed to pull the box. (You may need to practise pulling the block at a steady speed a couple of times.)
- Repeat twice at the same speed.
- Repeat for different speeds.
- Repeat for other materials.
- Work out the coefficient of kinetic friction between the surfaces.

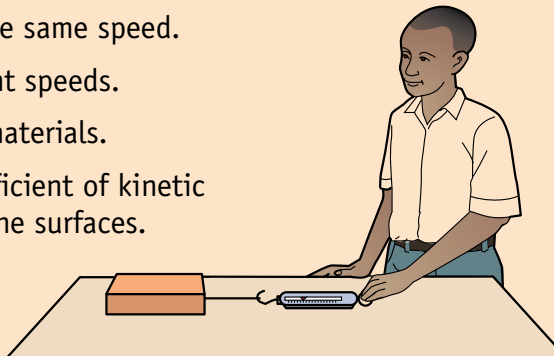

Figure 4.11 Pulling a block along a tabletop

Discussion activity

In about 1600, Galileo carried out a ‘thought’ experiment on motion. The line between A and B represents a surface and the dot at A is a ball. What would happen in each of the three situations shown in Figure 4.13, with and without friction when the ball is released. Why do you think Galileo had to carry this out as a thought experiment?

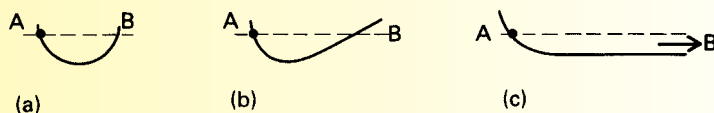

Figure 4.13 Galileo's thought experiment on motion

Newton and gravity

In Unit 3, you learned more about Newton's law of universal gravitation.

Newton's law of universal gravitation states that if two masses M_1 and M_2 are a distance r , then the gravitational force between them is given by the equation:

$$F = \frac{GM_1M_2}{r^2}$$

where G is the universal gravitational constant.

We can use it and Newton's laws of motion to help explain what we call gravity. Consider a mass m held above the Earth's surface and then released (Figure 4.14). It will of course drop, gaining velocity all the time, as they are attracted to each other according to the law of universal gravitation.

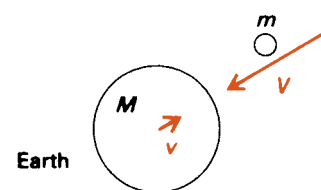

Figure 4.14 Both masses gain momentum

Worked example 4.5

A box is pulled along a flat table. The force used to move the box along the table is 7 N.

The mass of the box is 2 kg.

Work out the coefficient of kinetic friction.

Draw a free body diagram to show the forces (Figure 4.10).

The normal force

$$F_N = mg = 2 \times 9.8 = 19.6 \text{ N}$$

$$F_k = \mu_k F_N \text{ so}$$

$$\mu_k = F_k / F_N = 7 / 19.6 = 0.36$$

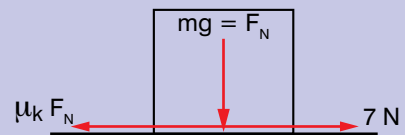

Figure 4.12

Activity 4.4

Repeat Activity 4.3, but this time with the block on a ramp. Measure the force needed to pull the block at a steady speed for different angles of the ramp.

What can you conclude from this?

This is the exact opposite of the case where two masses are moving apart from each other, but otherwise the principles are exactly the same:

$$Mv + mV = 0$$

The object accelerates rapidly towards the Earth, of course, but under the action of the same size force the opposite way, the Earth accelerates with its huge mass very slowly towards the object.

When an astronaut is in the International Space Station in orbit around the Earth, gravity is acting on both the International Space Station and the astronaut. The astronaut experiences the feeling of weightlessness because both the space station and the astronaut are falling continuously towards the centre of the Earth, but the sideways motion (the movement in orbit around the Earth) maintains the distance from the centre of the Earth.

In fact, eventually both the astronaut and the space station would fall to the Earth. In the space station, there is still a gravitational pull, but it is not as strong as it is on the surface of the Earth.

Summary

In this section you have learnt that:

- Newton's three laws of motion are fundamental to the movement of bodies.
- There are two types of friction: static friction and kinetic friction.
- The coefficient of static friction is found from the equation $F_s = \mu_s F_N$ where F_s is the frictional force, μ_s is the coefficient of static friction and F_N is the normal force.
- The coefficient of kinetic friction is found from the equation $F_k = \mu_k F_N$ where F_k is the frictional force, μ_k is the coefficient of kinetic friction and F_N is the normal force.

Review questions

1. A girl is on a bicycle cycling along a flat road. She applies a force to the pedals which produces a driving force of 1 kN. The mass of the girl is 65 kg and the mass of the bicycle is 20 kg.

There is a combined force of 500 N from friction and air resistance.

a) What will happen to the girl and bicycle.

b) The girl now cycles up a slope of 10° . What will happen to the girl and bicycle now?

(Hint: you need to consider the components of the forces that are acting in the plane she is travelling.)

2. Look at the diagram of the truck in Figure 4.15. The truck has a mass of 8 tonnes. What will happen to the truck?

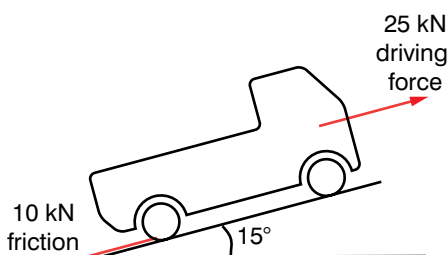

Figure 4.15

3. A book is on a ramp at angle of 10° to the horizontal. The book has a mass of 1.5 kg and the coefficient of static friction between the book and the ramp is 0.2.
Work out the frictional force between the book and the ramp.
4. A man puts a brick down on a concrete slope. The brick just starts to slip.
The angle of the slope is 35° . Work out the coefficient of static friction between the brick and the concrete.
5. A large table has a mass of 150 kg. The coefficient of static friction between the table legs and the ground is 0.45. The coefficient of kinetic friction between the table legs and the ground is 0.4.
a) What force is needed to start the table moving?
b) What force is needed to keep the table moving?
6. A person is dragging a 15 kg box along flat ground using a length of rope. The rope is at angle of 30° to the horizontal and the person is pulling with a force of 58 N.
Work out the coefficient of kinetic friction between the box and the ground.
7. What conditions are associated with an object that is moving at a constant velocity?
8. A truck is facing down a slope of 5° . The truck has a mass of 3000 kg. The driver lets of the brake and the truck accelerates down the slope. What is the acceleration of the truck?
What is the acceleration as a vector in component form?
9. A car is on a slope of 10° above the horizontal. A force of 1000 N is applied to the car up the line of the slope. The car has a mass of 500 kg.
What is the acceleration of the car?
Give your answer in vector form.

4.3 Law of conservation of linear momentum and its applications

By the end of this section you should be able to:

- Describe the terms momentum and impulse.
- State the law of conservation of linear momentum.
- Discover the relationship between impulse and momentum, according to Newton's second law.
- Apply quantitatively the law of conservation of linear momentum.

KEY WORDS

linear momentum *the product of the mass and velocity of a particle*

You learned in Grade 9 the meaning of the term momentum. The greater the mass and velocity of an object, the greater its momentum. Momentum is defined by the equation:

linear momentum = mass \times velocity or $p = mv$

The term linear is used to distinguish it from angular momentum. A body has angular momentum when it is spinning. The units of momentum are kg m/s.

As velocity is a vector and mass is a scalar, momentum is also a vector because when you multiply a vector by a scalar, you get a vector. The linear momentum of a body has the same direction as the velocity of the body.

So far we have used a simplified form of Newton's second law of motion. The full version includes momentum and is:

- **If a resultant force acts on a body, it will cause that body's momentum to change. The momentum change occurs in the direction of the force, at a rate proportional to the magnitude of that force.**

We can also *express* momentum as a vector. According to Newton's second law, the direction of the momentum will always be in the same direction as the velocity because mass always has a positive value.

In vector form: $\mathbf{p} = m\mathbf{v}$

We can also state Newton's second law in terms of momentum. The net force can be expressed in terms of change in momentum divided by time, or the rate of change of momentum.

$$\mathbf{F}_{\text{net}} = \Delta\mathbf{p}/\Delta t$$

Law of conservation of linear momentum

When two masses push each other apart, you can use Newton's third law of motion to predict the movement of one mass when you know the velocity of the other mass.

We can demonstrate this with two similar free-running trolleys – you could use something like the ones shown in Figure 4.16.

Add extra mass to one of them so that it has double the mass of the other one. Compress a stiff spring between them, keeping it squashed with a loop of thread holding it together, as shown in Figure 4.16.

Burn through the thread and the trolleys will push each other apart. All the time this is happening the trolley with double the mass will be accelerating at half the acceleration of the other, so by the end it will only have half its velocity, but in the opposite direction.

Activity 4.5

Consider a ball of mass 150 g thrown into the air with a velocity of 15 m/s at an angle of 60° to the horizontal.

- What happens to the momentum of the ball?
- What do you notice about the momentum when you express it in vector form?

Activity 4.6

Look at the units of each of the quantities in the two equations on the left. Check that the units on the left-hand side of the equation are the same as the ones on the right-hand side.

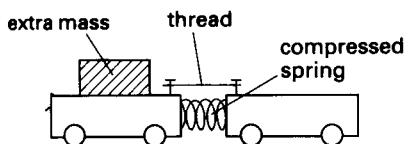

Figure 4.16 Demonstrating the conservation of linear momentum

Worked example 4.6

Consider a large mass and a small mass which are pushing one another apart, as shown in Figure 4.17. The small mass moves away at a velocity of 10 m/s to the right. What is the recoil velocity of the large mass?

According to Newton's third law, the forces exerted by each mass on the other are equal in magnitude but opposite in direction. Each force causes the momentum of the body on which it acts to change. During the time which they push each other apart, A and B gain momentum. Taking our frame of reference to be positive to the right, A gains momentum p_A and B gains momentum p_B .

Using Newton's third law: $p_A = -p_B$

but $p_A = m_A v_A$ and $p_B = m_B v_B$

so $m_A v_A = -m_B v_B$

$$v_A = -m_B v_B / m_A$$

Substituting the values into the equation

$$v_A = -2 \text{ kg} \times 10 \text{ m/s} / 5 \text{ kg}$$

$$= -4 \text{ m/s}$$

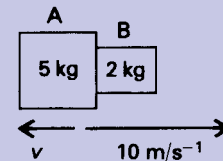

Figure 4.17

This example illustrates a particular case of a general principle – the conservation of linear momentum. The principle is:

- **If two bodies collide or push each other apart and no forces act except for each one pushing on the other, the total momentum of the two bodies does not change.**

Looking at the worked example, at the start the total momentum of both bodies was zero. After the bodies have moved apart the total momentum is

$$p + -p = 0$$

So the total momentum of the two bodies has not changed.

In Grade 9, we applied the law of conservation of momentum in one dimension. Now we will apply the law in two dimensions.

The principle is:

$$m_1 \mathbf{u}_1 + m_2 \mathbf{u}_2 = m_1 \mathbf{v}_1 + m_2 \mathbf{v}_2$$

where \mathbf{u}_1 , \mathbf{u}_2 , \mathbf{v}_1 and \mathbf{v}_2 are vectors.

Activity 4.7

Find two students with approximately the same mass. Ask them to stand on platforms with wheels, facing each other, as shown in Figure 4.18.

One student pushes the other away gently, in an attempt to make him or her move away. What happens?

Does it make any difference which student does the pushing, or if both push?

Try again with students of different masses.

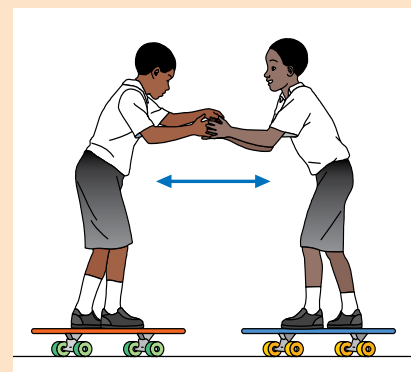

Figure 4.18 What will happen if one student pushes on the other?

Worked example 4.7

Two roads are perpendicular and meet at a junction.

Car A of mass 1000 kg travels along one road at 20 m/s due North.

Car B of mass 1300 kg, travels due West along the other road at 16 m/s.

At the junction the cars collide and move together.

- Write down the initial velocities of the cars before collision in vector form.
- Find the velocity of the cars after collision.

First draw a diagram of the cars before collision (Figure 4.17).

- Assume North and West to be positive in our frame of reference. The initial velocities are:

$$\text{car A: } \begin{bmatrix} 0 \\ 20 \end{bmatrix} \text{ m/s}$$

$$\text{car B: } \begin{bmatrix} 16 \\ 0 \end{bmatrix} \text{ m/s}$$

$$\begin{aligned} \text{b) momentum before collision} &= 1000 \begin{bmatrix} 0 \\ 20 \end{bmatrix} \text{ kg m/s} \\ &+ 1300 \begin{bmatrix} 16 \\ 0 \end{bmatrix} \text{ kg m/s} \\ &= \begin{bmatrix} 20\,800 \\ 20\,000 \end{bmatrix} \text{ kg m/s} \end{aligned}$$

$$\begin{aligned} \text{momentum after collision} &= (1000 + 1300) \mathbf{v} \text{ kg m/s} \\ &= 2300\mathbf{v} \text{ kg m/s} \end{aligned}$$

$$\begin{aligned} \text{So } \mathbf{v} &= \begin{bmatrix} 20\,800/2300 \\ 20\,000/2300 \end{bmatrix} \text{ m/s} \\ &= \begin{bmatrix} 9.04 \\ 8.70 \end{bmatrix} \text{ m/s} \end{aligned}$$

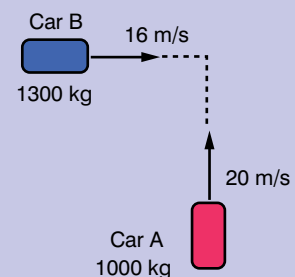

Figure 4.19

Activity 4.8

In each of the following cases, describe what happens and try to explain it in terms of the conservation of momentum.

- One student stands on a trolley. Another student who is standing on the floor throws a ball filled with sand to the student on the trolley.
- Two students are each on stationary trolleys. One of them has a ball filled with sand and throws it to the other student.

Impulse

In Grade 9 you learned that an impulse is when you change the momentum of an object. As the mass does not change, it is the velocity that changes when the momentum is changed. The equation is:

impulse = mass × change in velocity or

$$I = m\Delta v$$

You also learned that the impulse is related to the force used to change the momentum and the length of time the force was applied for. The equation is:

$$I = F\Delta t$$

The units of impulse are newton seconds or N s, which are the same as momentum.

Discussion activity

Put the two equations for impulse together. Can you see a link between them? What equation does it resemble?

Worked example 4.8

A ball of mass 500 g and velocity $\begin{bmatrix} 5 \\ 2 \end{bmatrix}$ m/s bounces off a vertical wall.

- a) What is the impulse of the ball?
 b) The ball changes direction in 0.1 s.
 What is the force exerted by the wall on the ball?

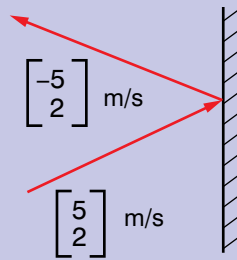

Figure 4.20

- a) First draw a diagram showing the known variable (Figure 4.20).

Assume the frame of reference to be Cartesian coordinates, that is positive x-direction is to the right and positive y-direction is upwards.

Use the equation $p = mv$ to find the momentum before and after collision, and then $I = m\Delta v$ to find the impulse.

$$\text{Momentum before collision} = 0.5 \times \begin{bmatrix} 5 \\ 2 \end{bmatrix} = \begin{bmatrix} 2.5 \\ 1.0 \end{bmatrix} \text{ kg m/s}$$

$$\text{Momentum after collision} = 0.5 \times \begin{bmatrix} -5 \\ 2 \end{bmatrix} = \begin{bmatrix} -2.5 \\ 1.0 \end{bmatrix} \text{ kg m/s}$$

$$\text{Impulse} = \text{change in momentum} = \begin{bmatrix} 2.5 \\ 1.0 \end{bmatrix} - \begin{bmatrix} -2.5 \\ 1.0 \end{bmatrix} \text{ kg m/s}$$

$$= \begin{bmatrix} 5 \\ 0 \end{bmatrix} \text{ kg m/s}$$

- b) Use the equation $I = F\Delta t$ and rearrange it to find the force exerted by the wall.

$$F = I/\Delta t$$

$$\text{Force exerted by wall} = \begin{bmatrix} 5 \\ 0 \end{bmatrix} / 0.1 = \begin{bmatrix} 50 \\ 0 \end{bmatrix} \text{ N}$$

DID YOU KNOW?**The recoil-less rifle**

During the Second World War, a so-called recoil-less rifle was developed. It is so effective that a person can fire a shell that can pierce a tank's armour without suffering so much recoil that the person's shoulder is broken.

It does not defy Newton's third law, though. It fires two objects simultaneously in opposite directions. The shell comes out of the front of the gun, of course. At the back, a blast of compressed gases comes out, which is so intense that it could kill someone standing behind the rifle.

Newton's cradle

Figure 4.21 A Newton's cradle relies on the law of conservation of linear momentum to work.

Seat belts

The effect of a force is to change a body's motion. Or, if you want to change the motion of a body, you need to apply a force.

When you drive a car and have to do an emergency stop, you put your foot hard on the brake pedal. The brakes exert a decelerating force on the car. You keep moving at the same velocity until you come across something that will provide the force to change your motion. If you are wearing a seat belt, this will exert a force on you which will change your motion. If you don't, you will hit the windscreen and the windscreen will provide the force to change your motion.

Crumple zones on cars

One way to reduce potential injuries in a car accident is to reduce the force exerted on the body to stop it. To reduce the force, you need to reduce the deceleration.

Another way of looking at this is to increase the time it takes for your momentum to change. One way of doing this is to have crumple zones on a car. As a car crashes, it compresses and so your momentum changes in a longer time, and the forces on you are less.

Activity 4.9

A car hits a wall at 20 m/s. The mass of one of the passengers is 75 kg.

The passenger comes to a halt in 0.01 s.

A second car hits a similar wall at the same speed. This car has crumple zones at the front. As the car hits the wall, the crumple zone works and the passenger comes to a halt in 0.1 s (Figure 4.22).

Draw free body diagrams to show the forces on the passengers.

Analyse the forces and accelerations on the two passengers, using the impulse-momentum equations given above.

What conclusions can you draw about the passengers in the two cars? What implications does this have for safety features in a car.

Figure 4.22
Crash testing
a car



Summary

In this section you have learnt that:

- Linear momentum is mass multiplied by velocity and is a vector.
- Total momentum of a system of bodies stays the same unless a force acts on them to change the momentum.
- The law of conservation of momentum can be used to help explain gravity.
- Impulse is the change in momentum.
- Impulse and momentum have the same units.
- Increasing the length of time to change the momentum reduces the size of the force needed to change the momentum.

Review questions

1. A ball of mass 4 kg falls on to the floor with a velocity of $\begin{bmatrix} 4 \\ -9 \end{bmatrix}$ m/s.
It bounces off the floor with a velocity of $\begin{bmatrix} 4 \\ 9 \end{bmatrix}$ m/s.
What is the impulse of the ball?
The ball changes direction in 0.15 s. What is the force exerted by the floor on the ball?
2. A boy drops a stone of mass 200 g from a height of 2 m.
 - a) What is the momentum of the stone just before it hits the floor?
 - b) What is the impulse of the stone?
 - c) The stone comes to a halt in 0.05 s. What is the force exerted on the stone?
3. A bullet of mass 0.01 kg is fired with a velocity of $\begin{bmatrix} 200 \\ 0 \end{bmatrix}$ m/s into a sack of sand of mass 9.99 kg which is swinging from a rope. At the moment the bullet hits, the sack has a velocity of $\begin{bmatrix} 0 \\ 0.2 \end{bmatrix}$ m/s.
Work out the velocity of the bullet and sack just after the bullet hits the sack.
4. Particle A is travelling at a velocity of $\begin{bmatrix} 6 \\ -2 \end{bmatrix}$ m/s. It collides with particle B which has a velocity of $\begin{bmatrix} 10 \\ 8 \end{bmatrix}$ m/s. The particles move together. The mass of particle A is 2 kg and the mass of particle B is 3 kg.
Find the velocity of the combined particles after the collision.

KEY WORDS

elastic collision *a collision between two particles where kinetic energy is conserved*

inelastic collision *a collision between two particles where kinetic energy is not conserved*

Activity 4.10

We can also demonstrate collisions using an air track, such as the one shown in Figure 4.4. How would you demonstrate elastic and inelastic collisions?

DID YOU KNOW?

Collisions are used in atomic and nuclear physics to investigate the properties of particles. Particles have been discovered by looking at the tracks of particles after they have collided.



Figure 4.23 Particles are collided in a particle accelerator like this one.

4.4 Elastic and inelastic collisions in one and two dimensions

By the end of this section you should be able to:

- Distinguish between elastic and inelastic collisions.
- Describe head-on collisions.
- Describe glancing collisions.

In Grade 9, you learned that in a collision, momentum is conserved and you applied this in one dimension. Here, we will extend this to collisions in two dimensions.

Consider two identical masses approaching each other. One has velocity v , the other has velocity $-v$. Their combined momentum is $mv + (-mv)$, which is zero.

We know that after they collide their total momentum will still be zero, but we cannot predict exactly what will happen without further information.

If they were both balls of soft uncooked dough, they would merge together to form a single stationary lump of mass. As v is now zero, the total momentum is zero, and momentum has been conserved. This is an **inelastic collision**.

If they were two balls of hard spring steel, they would rebound off each other. The first ball would now have a velocity of $-v$ and the second one a velocity of $+v$. The total momentum is still zero, so momentum has been conserved. This is an elastic collision. Molecules in a gas collide like this.

In all collisions momentum is conserved. The difference between an elastic collision and an inelastic collision is that kinetic energy is conserved in an **elastic collision**, but not in an inelastic collision. The kinetic energy is transferred into other forms of energy.

Activity 4.11

Use two toy cars or laboratory trolleys. Attach magnets so that they repel each other when they collide.

- Push one car towards the other; observe how momentum is transferred to the second one.
- Try adding masses to the cars. How does this affect how they move after the collision?
- What happens if both cars are moving when they collide?
- Reverse one of the magnets so that the cars stick together when they collide. Does momentum still appear to be conserved?

Worked example 4.9

The cue ball in a pool game is travelling at $\begin{bmatrix} 3 \\ -2 \end{bmatrix}$ m/s. It collides with a pool ball which is stationary. After the collision, the pool ball moves with a velocity of $\begin{bmatrix} 2 \\ 0.5 \end{bmatrix}$ m/s.

What is the velocity of the cue ball after the collision?

The cue ball has a mass of 90 g, and the pool ball has a mass of 100 g.

First draw a diagram showing the known variables and the unknown one (Figure 4.24).

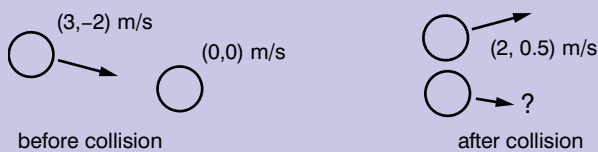

Figure 4.24

$$\text{Momentum before collision} = 0.09 \times \begin{bmatrix} 3 \\ -2 \end{bmatrix} = \begin{bmatrix} 0.27 \\ -0.18 \end{bmatrix} \text{ kg m/s}$$

$$\begin{aligned} \text{Momentum after collision} &= 0.1 \times \begin{bmatrix} 2 \\ 0.5 \end{bmatrix} + 0.09 \times \begin{bmatrix} x \\ y \end{bmatrix} \text{ kg m/s} \\ &= \begin{bmatrix} 0.2 \\ 0.05 \end{bmatrix} + \begin{bmatrix} 0.09x \\ 0.09y \end{bmatrix} \text{ kg m/s} \end{aligned}$$

As momentum after collision = momentum before collision

$$\begin{bmatrix} 0.2 \\ 0.05 \end{bmatrix} + \begin{bmatrix} 0.09x \\ 0.09y \end{bmatrix} = \begin{bmatrix} 0.27 \\ -0.18 \end{bmatrix}$$

$$\begin{bmatrix} 0.09x \\ 0.09y \end{bmatrix} = \begin{bmatrix} 0.27 - 0.2 \\ -0.18 - 0.05 \end{bmatrix}$$

$$\begin{bmatrix} x \\ y \end{bmatrix} = \begin{bmatrix} 0.07/0.09 \\ -0.23/0.09 \end{bmatrix} = \begin{bmatrix} 0.78 \\ -2.56 \end{bmatrix} \text{ m/s}$$

So the velocity of the cue ball is $\begin{bmatrix} 0.78 \\ -2.56 \end{bmatrix}$ m/s

Head-on collisions

You learned about collisions in one dimension in Grade 9. A collision in one dimension is also known as a **head-on collision**. We can use the law of conservation of linear momentum and the fact that kinetic energy is conserved in an elastic collision.

Glancing collisions

A **glancing collision** is a collision in two dimensions. We apply the principles in exactly the same way as for a head-on collision, but in two dimensions.

Activity 4.12

Carry out some collisions with billiard balls on a smooth surface. Have one billiard ball stationary on the smooth surface. Roll another billiard ball down a ramp and onto the flat surface so that it collides with the stationary billiard ball.

- Work out the velocity of the first billiard ball before collision. How can you do this if you know the height of the ramp?
- Measure the velocities of the two balls after collision.
- Plan your experiment and carry it out.
- Can you use your results to predict the results of another collision?
- Write up a report of your experiment using the writing frame in Unit 1.

KEY WORDS

glancing collision a collision in two dimensions, where the objects rebound in the same plane but not necessarily the same direction as the original motion

head-on collision a collision in one dimension, where the objects rebound on straight line paths that coincide with the original direction of motion

Worked example 4.10

Car A collides with car B, which is stationary and then both cars move together.

Before the collision, car A had a velocity of 5 m/s. The masses of car A and car B are 1250 kg and 1500 kg, respectively.

What is the speed of the two cars after the collision?

First draw a diagram to show all the known variables and the unknown.

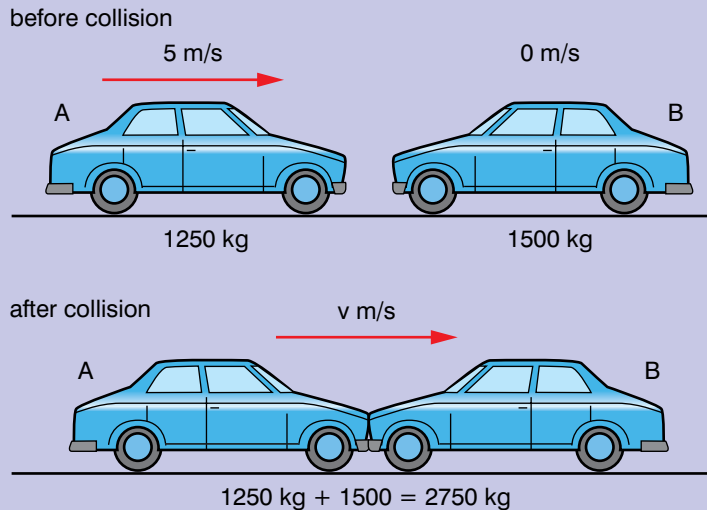

Figure 4.25

Use the law of conservation of momentum and the equation $p = mv$

$$m_A v_A + m_B v_B = (m_A + m_B)v$$

As $v_B = 0$, this term in the equation is zero. Rearrange the equation to find v_{AB} :

$$v_{AB} = m_A v_A / (m_A + m_B)$$

Substituting in the values:

$$v_{AB} = (1250 \text{ kg} \times 5 \text{ m/s}) / (1250 \text{ kg} + 1500 \text{ kg})$$

$$= 6250 \text{ kg m/s} \div 2750 \text{ kg} = 2.3 \text{ m/s}$$

Summary

In this section you have learnt that:

- Kinetic energy is conserved in an elastic collision but not in an inelastic collision.
- The total momentum of a system of bodies before a collision is the same as the total momentum of the system after the collision.
- Problems involving collisions can be solved by considering the momentum before and after the collision.

Review questions

1. A is a sphere that is travelling with a velocity of $(3, 7)$ m/s and had a mass of 5 kg.
It collides with sphere B and both particles move together with a velocity of $(1, 4)$ m/s after the collision. Sphere B has a mass of 4 kg.
Find the velocity of B before the collision.
2. Two particles collide and come to rest. The first particle has mass 5 kg and a velocity $(8, -9)$ m/s before the collision. The second particle has a mass of 2 kg.
Find the velocity of the second particle before the collision.
3. A pool ball of mass 100 g and velocity $(5, -4)$ m/s collides with a stationary pool ball of the same mass. After the collision, one of the pool balls has a velocity $(2, -3)$ m/s.
Find the velocity of the other pool ball.

4.5 Centre of mass

By the end of this section you should be able to:

- Define and describe the concepts and units related to torque.
- Describe centre of mass of a body.
- Determine the position of centre of mass of a body.

KEY WORDS

centre of mass *the point in a body from which the force of gravity on that body appears to be acting*

torque *the turning effect of a force round a point*

When you apply two forces to an object, as shown in Figure 4.26, the forces cause the body to rotate. This turning effect of the forces is called a moment or torque. Think back to the work you did on levers – you found that you could move a large mass using a lever if the distance you applied the load was a long way from the pivot. The forces are not acting in the same line. There are moments about the pivot.

The moment of a force or **torque** is defined as the magnitude of the force multiplied by the perpendicular distance from the point to the force of the line of action of the force. A moment, or the torque, is also the vector product of the force and the distance from the point. Torque has direction and so is also a vector.

Look at Figure 4.27 overleaf, which shows two masses connected by a rod. There is a point between the two masses m_1 and m_2 where they will balance, like a see-saw. The torque tries to move the objects around the point.

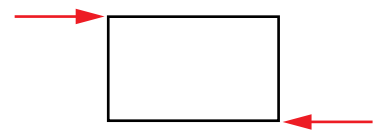

Figure 4.26 *The turning effect of two forces acting on a block*

Activity 4.13

Set up a see-saw using a ruler and pivot. Put one mass on one side of the pivot. Can you use the principle of moments to predict where you will need to put double the mass on the other side of the pivot?

Activity 4.14

Stand a box on its smallest side on a flat surface. Push it over slightly and let it go.

Push it over a bit further and let it go. What happens?

Keep increasing the angle you push the box over to.

Can you find the angle where the box balances?

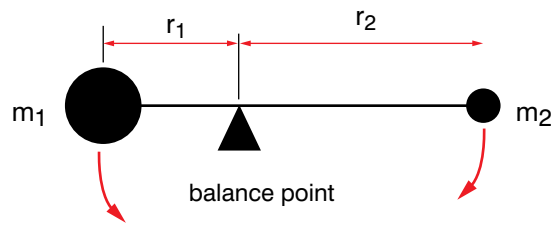

Figure 4.27 Torque acting on masses

In Figure 4.27, when the **centre of mass** is above the balance point, the rods balance. At this point the torque on m_1 is balanced by the torque on m_2 . The torque on m_1 is trying to turn the rod anti-clockwise and the torque on m_2 is trying to turn the rod clockwise. Both force and displacement are vectors.

Worked example 4.11

Look at Figure 4.28. The two masses are balanced. What is the distance of the 2.5 kg mass from the balance point?

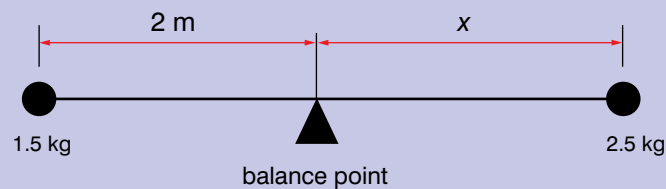

Figure 4.28 Balanced system of two masses

When the system is balanced, the moments about the balance point sum to zero.

$$\text{On the left: } \tau_1 = -2 \text{ m} \times (1.5 \times 9.8) \text{ N}$$

$$\text{On the right: } \tau_2 = x \times (2.5 \times 9.8) \text{ N}$$

$$\tau_1 + \tau_2 = 0$$

$$-2 \text{ m} \times (1.5 \times 9.8) \text{ N} + x \times (2.5 \times 9.8) \text{ N} = 0$$

$$x = (2 \times 1.5) / 2.5 = 1.2 \text{ m}$$

The anticlockwise moment is:

$$\tau_1 = r_1 \times m_1 g$$

The clockwise moment is:

$$\tau_2 = r_2 \times m_2 g$$

When the system is balanced:

$$\tau_1 + \tau_2 = 0$$

We can also say that the system is balanced because the centre of mass is above the pivot point. Taking moments about a point helps us to explain the centre of mass. The position of the centre of mass explains why some objects are stable and others are not.

Finding the centre of mass

We can use moments to find the position of the centre of mass in a system.

Worked example 4.12

The diagram shows a rod with two masses attached to it. The distances from P are shown on the diagram. The rod is massless.

The moments of the two masses can be balanced by a single force F acting at a distance x from the left hand end of the rod. Calculate x .

Use the equation $\tau = rF$

Draw a diagram to show the forces acting on the rod.

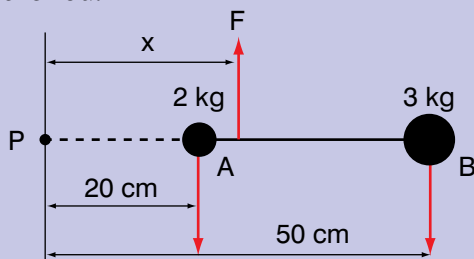

Figure 4.29

Anticlockwise moment about P = xF

Clockwise moment about P = $x_A m_A g + x_B m_B g$

When the rod is balanced, $F = m_A g + m_B g$

and $xF - x_A m_A g - x_B m_B g = 0$

$$\text{So } x = \frac{(x_A m_A g + x_B m_B g)}{F}$$

Substituting for F :

$$x = (x_A m_A g + x_B m_B g) / (m_A g + m_B g)$$

$$= (x_A m_A + x_B m_B) / (m_A + m_B)$$

Substituting in the values:

$$x = (0.2 \text{ m} \times 2 \text{ kg} + 0.5 \text{ m} \times 3 \text{ kg}) / (2 \text{ kg} + 3 \text{ kg})$$

$$= (0.4 + 1.5) / 5 = 1.9 / 5 = 0.38 \text{ m}$$

So the force would need to be applied 38 cm from the left hand end of the rod.

The worked example above shows us that the centre of mass of the two masses is 38 cm from the left hand end of the rod. We can extend this result to find the centre of mass of any system of particles in two dimensions:

$$x_{\text{cm}} = \frac{m_1 x_1 + m_2 x_2 + \dots}{m_1 + m_2 + \dots}$$

$$y_{\text{cm}} = \frac{m_1 y_1 + m_2 y_2 + \dots}{m_1 + m_2 + \dots}$$

where the distances are the distances from a common reference point.

When the centre of mass is directly above a point that is inside the base of an object, it will be stable, as shown in Figure 4.30. When the centre of mass is directly above a point which is outside the base of an object, the object will become unstable and fall over. The object will fall into a position where the centre of mass is directly over a point that is inside the new base of the object.

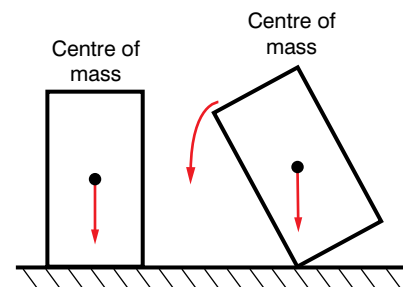

Figure 4.30 How the position of the centre of mass affects the stability of an object

Activity 4.15

You are going to find the centre of mass of a piece of card (Figure 4.31).

- Hang the card from one corner. Draw a vertical line from the point where the card is hanging.
- Repeat for different parts of the card.
- The place where the lines cross is the centre of mass.
- Cut an irregular shape from a piece of card and find its centre of mass.



Figure 4.31 Finding the centre of mass of a planar object

Activity 4.16

Kneel on a flat surface with your forearms flat on the surface and your elbows touching your knees (Figure 4.32a).

Place a short object such as a cigarette lighter or a matchbox at the tips of your outstretched fingers.

Now place your hands behind your back and try to tip the object over with your nose without losing your balance (Figure 4.32b).

Can you do it? Can you explain why?

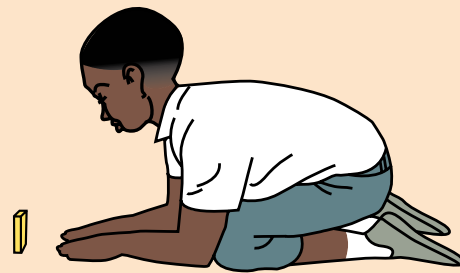

Figure 4.32a



Figure 4.32b

DID YOU KNOW?

High jumpers use the Fosbury flop to help them get over the bar. When they do this, they bend their bodies so that their bodies clear the bar, but their centre of mass does not!



Figure 4.33 A high jumper doing the Fosbury flop

Summary

In this section you have learnt that:

- Torque is the turning effect of a force.
- The centre of mass is where the whole of the force of gravity on that body appears to be acting from.
- The centre of mass can be outside an object.
- Objects are stable when the centre of a mass is above a point that is inside the base of the object.

Review questions

1. A 250 g mass is 15 cm from the centre of a bar. Where should a 400 g mass be placed to balance the bar?
2. A bar is 20 cm long. A 100 g mass is placed on one end and a 150 g mass on the other. Where is the balance point of the bar?
3. Two masses (3 kg and 5 kg) are placed at opposite ends of a massless rod of length 1.5 m.
Find the distance of the centre of mass from the 3 kg mass.
4. Find the distance of the centre of mass of the system shown in the diagram from point A. The rod is massless.

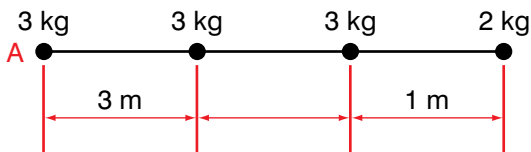

Figure 4.34

5. Find the centre of mass of each of the following systems with respect to corner O. The frame joining the masses is massless.

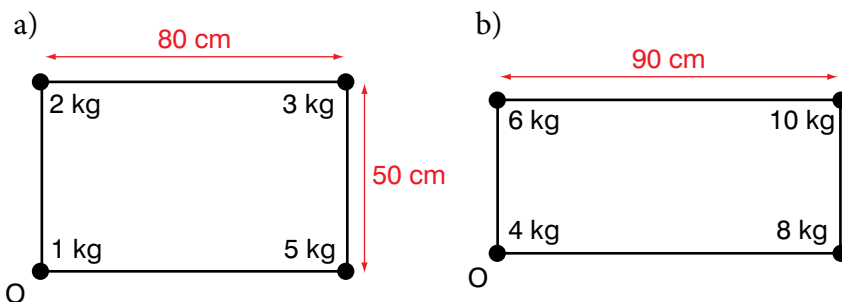

Figure 4.35

6. Calculate the mass of mass A in the diagram. The frame joining the masses is massless.

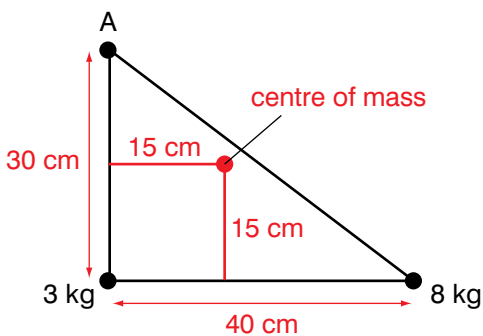

Figure 4.36

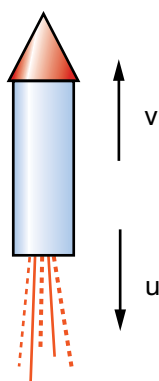

Figure 4.37 A rocket

Activity 4.17

Consider a rocket as shown in Figure 4.37. In small groups discuss the following:

- What happens to its mass?
- What happens to the acceleration of the rocket?
- How does the acceleration change while the engine is running?
- Do you think the rate of change of momentum is constant?

4.6 Momentum conservation in a variable mass system

By the end of this section you should be able to:

- Describe explosions and rocket propulsion in relation to momentum conservation.

A rocket uses Newton's third law of motion to move. The upwards force on the rocket is balanced by the downwards force from the gases going out through the rocket nozzle (Figure 4.37). However, we cannot apply Newton's second law of motion directly because the mass of the rocket is not constant. The mass of the rocket decreases as more gases are pushed out of the nozzle of the rocket. This also means that the rocket is losing some momentum as the gases leave the rocket.

We can express Newton's second law in this form:

$$F + u\Delta m = ma$$

where F is the force on the rocket, u is the velocity of the exhaust gases relative to the centre of mass of the rocket, $\frac{\Delta t}{\Delta m}$ is the mass of exhaust gases expelled at a point in time (or the rate of change of mass of the rocket), m is the mass of the rocket and a is the acceleration (or the rate of change in v , velocity of the rocket).

When the rate of change of mass is zero, this becomes Newton's second law of motion.

We need a generalisation of Newton's second law, which we covered in Section 4.3:

force = rate of change of momentum

Worked example 4.13

A toy rocket produces a force of 10 N. The mass of the rocket at launch is 200 g.

What is the acceleration of the rocket?

First draw a diagram showing the forces on the rocket (Figure 4.38).

There is a force downwards on the rocket which is the weight of the rocket. So the net force on the rocket is:

$$F = 10 \text{ N} - 0.2 \text{ kg} \times 9.8 \text{ m/s}^2 = 10 - 1.96 = 8.04 \text{ N}$$

$$\text{acceleration} = \frac{8.04}{0.5} \text{ m/s}^2 = 16.1 \text{ m/s}^2$$

So the acceleration of the rocket is 16.1 m/s² upwards.

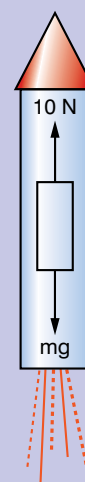

Figure 4.38

A raindrop is another example of a variable mass system. Droplets of condensed water vapour combine until they start falling through the cloud as a raindrop. The raindrops then get bigger as they combine with other droplets of water to form bigger raindrops. As the mass of raindrop increases, the momentum of the raindrop increases.

The force acting on the raindrop at a certain time can be expressed as:

$$F = \text{rate of change of momentum} = ma + \frac{u\Delta m}{\Delta t}$$

where F is the force on the raindrop, m is the mass of the raindrop, u is the velocity of the extra mass that has been added to the raindrop and u is the velocity of the extra mass.

We can also consider what happens in explosions.

Worked example 4.14

An 1 kg object explodes and breaks up into three pieces.

One piece has a mass of 400 g and has a velocity of $\begin{bmatrix} 15 \\ 10 \end{bmatrix}$ m/s.

A second piece has a mass of 250 g and has a velocity of $\begin{bmatrix} 25 \\ -10 \end{bmatrix}$ m/s.

What is the velocity of the third piece?

First draw a diagram to show the explosion (Figure 4.39).

We know that the total mass is 1 kg and the masses of the other two pieces are 400 g and 250 g, so the mass of the third piece is 350 g.

As the momentum before the explosion is zero, the total momentum after the explosion is also zero. So:

$$0.4 \times \begin{bmatrix} 15 \\ 10 \end{bmatrix} + 0.25 \times \begin{bmatrix} 25 \\ -10 \end{bmatrix} + 0.35 \times \begin{bmatrix} x \\ y \end{bmatrix} = 0$$

$$\begin{bmatrix} 6 \\ 4 \end{bmatrix} + \begin{bmatrix} 6.25 \\ -2.5 \end{bmatrix} + \begin{bmatrix} 0.35x \\ 0.35y \end{bmatrix} = 0$$

$$\begin{bmatrix} 0.35x \\ 0.35y \end{bmatrix} = \begin{bmatrix} -12.25 \\ 1.5 \end{bmatrix}$$

$$\begin{bmatrix} x \\ y \end{bmatrix} = \begin{bmatrix} -35 \\ 4.3 \end{bmatrix} \text{ m/s}$$

So the velocity of the third piece is $\begin{bmatrix} -35 \\ 4.3 \end{bmatrix}$ m/s.

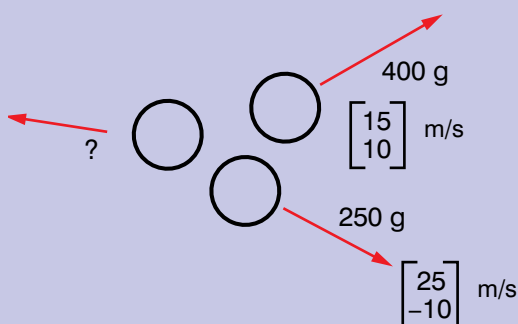

Figure 4.39

Activity 4.18

Attach a balloon to a trolley by holding it inside netting (Figure 4.40). Blow up the balloon and let the trolley go.

- What acceleration does the balloon give the trolley?
- What happens if you put a board immediately behind the trolley? Does this increase or decrease the acceleration of the trolley?

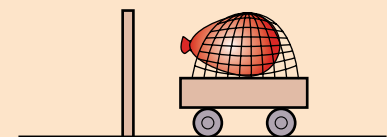

Figure 4.40

Summary

In this section you have learnt that:

- In a rocket, the mass changes while the engine is running.
- When the force is constant, the acceleration on a rocket increases while the engine is running.
- The law of conservation of momentum can be used to solve problems involving explosions.

Review questions

1. A toy rocket has a mass of 350 g at launch. The force it produces is 15 N and it is fired at an angle of 65° to the horizontal. What is the initial acceleration of the rocket as a vector?
2. A body of mass 50 kg explodes and splits into three pieces. The first piece has a mass of 10 kg and a velocity of $\begin{bmatrix} -18 \\ 23 \end{bmatrix}$ m/s, the second piece has a mass of 18 kg and a velocity of $\begin{bmatrix} 25 \\ -12 \end{bmatrix}$ m/s. What is the velocity of the third piece?
3. A body explodes and splits into three pieces. The first piece has a mass of 1.25 kg and a velocity of $\begin{bmatrix} 30 \\ -10 \end{bmatrix}$ m/s, the second piece has a mass of 3.25 kg and velocity of $\begin{bmatrix} -17 \\ 10 \end{bmatrix}$ m/s. The third piece has a velocity of $\begin{bmatrix} 35.5 \\ 40 \end{bmatrix}$ m/s
 - a) What is the mass of the third piece?
 - b) What was the total mass of the body before the explosion?

4.7 Dynamics of uniform circular motion

By the end of this section you should be able to:

- Interpret Newton's laws and apply these to moving objects undergoing uniform circular motion.
- Solve dynamics problems involving friction.

In Unit 3, we looked at uniform circular motion in both horizontal and vertical circles. Here we are going to look at the forces involved in keeping a body moving in uniform circular motion.

When a car is going round a bend, there is a force towards the centre of a circle that keeps the car moving in an arc of a circle round the bend. This force is provided by friction between the tyres of the car and the road.

One way of reducing the force needed to keep a car moving in a circle is to bank the track. Racetracks use this principle and well-constructed roads also use banking to make them safer.

Activity 4.19

You are designing a fairground ride where people will be spun round in circles on the inside of a drum. The floor of the drum is taken away leaving the riders stuck to the inner surface of the drum.

The drum then lifts up and rotates at an angle of 45° to the horizontal.

What data would you need to design the ride so that people are safe when the floor is removed and it tips up to 45° to the horizontal?

Worked example 4.15

A boy is sitting on the horizontal part of a roundabout 1 m from the centre. When the angular velocity of the roundabout exceeds 1 rad/s, the boy starts to slip.

Find the coefficient of friction between the boy and the surface.

First draw a diagram (Figure 4.41).

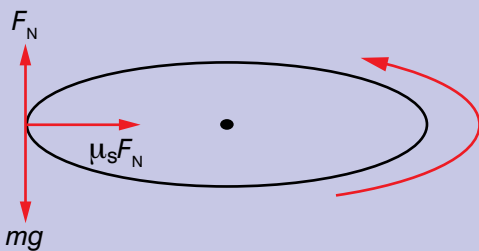

Figure 4.41

For the boy to just not slip or not to be moving with respect to the surface of the roundabout, the friction must be limiting. The forces in both the horizontal and the vertical directions are equal, as shown in the diagram

$$\text{Normal force} = mg$$

In the horizontal direction the frictional force is:

$$F_s = \mu_s F_N = \mu_s mg$$

but the force towards the centre is also his mass multiplied by his acceleration

$$F = m\omega^2 r$$

$$\text{So } \mu_s mg = m\omega^2 r \text{ and}$$

$$\mu_s = \omega^2 r / g = 1^2 \times 1 / 9.8 = 0.11$$

The coefficient of friction between the boy and the surface of the roundabout is 0.11.

Figure 4.42 This cycle track makes use of banked curves, which means that the cyclists can go around the bends at each end of the track quicker.



Worked example 4.16

A racetrack has a bend that is banked at an angle of 10° and has a radius of 200 m. A racing car has a mass of 750 kg and the coefficient of static friction between the tyres and the road surface is 0.6.

What is the fastest speed the racing car can go round this bend?

Draw a free body diagram showing the forces (Figure 4.43).

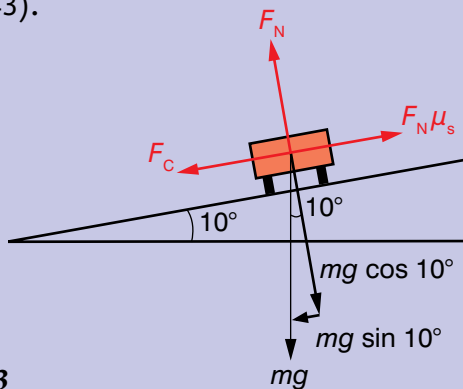

Figure 4.43

There is a centripetal force acting towards the centre of curvature of the bend, which is given by the equation

$$F_c = \frac{mv^2}{r}$$

The force normal to the plane of the racetrack is given by the component of the racing car's weight, which acts in this direction and is given by

$$F_N = mg \cos 10^\circ$$

The frictional force between the racing car's wheels and the track is given by the equation:

$$F_s = \mu_s F_N = \mu_s mg \cos 10^\circ$$

When the car starts to slip, the friction is limiting. The force of friction will be equal to the centripetal force acting on the car

$$F_c = F_s$$

$$\text{So } \frac{mv^2}{r} = \mu_s mg \cos 10^\circ$$

$$v^2 = \frac{\mu_s mg \cos 10^\circ r}{m}$$

$$= \mu_s g \cos 10^\circ r$$

$$= 0.6 \times 9.8 \text{ m/s} \times 0.985 \times 200 \text{ m}$$

$$= 1158 \text{ m}^2/\text{s}^2$$

$$\text{So } v = \sqrt{1158} = 34 \text{ m/s}$$

Activity 4.20

Set up a newtonmeter, string and mass up as shown in Figure 4.44. With one hand, hold on to the newtonmeter. With the other hand, hold on to the tubing and swing the mass in a horizontal circle.

- What force are you measuring?
- What do you notice about the force?
- Now try swinging the mass in a vertical circle. What do you notice about the force?

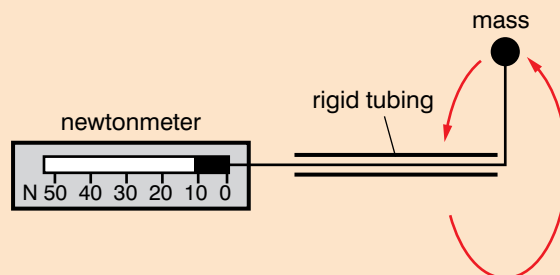

Figure 4.44

The forces acting on a body that is moving in a vertical circle are not constant. The centripetal force depends on the angle θ . The forces are shown in Figure 4.45.

The radial force (towards the centre of the circle) is $T - mg \cos \theta$.

The tangential force is $mg \sin \theta$.

We also know that the radial force is mv^2/r or $m\omega^2r$

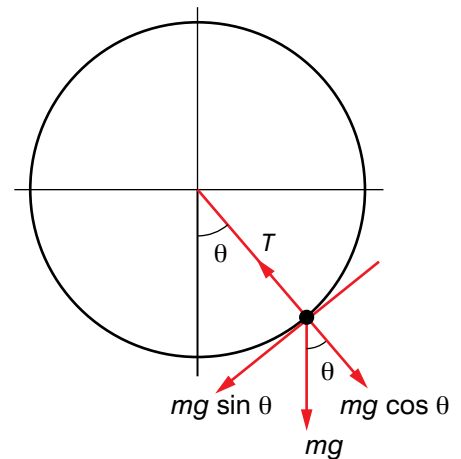

Figure 4.41

Worked example 4.17

A roller coaster moves through a loop. At an angle of 60° to the bottom of the loop it has a velocity of 14 m/s.

The mass of the roller coaster and riders is 750 kg. The diameter of the loop is 20 m.

What is the force acting on the roller coaster at an angle of 60° to the bottom of the loop?

Draw a free body diagram for when the roller coaster is at an angle of 60° (Figure 4.46).

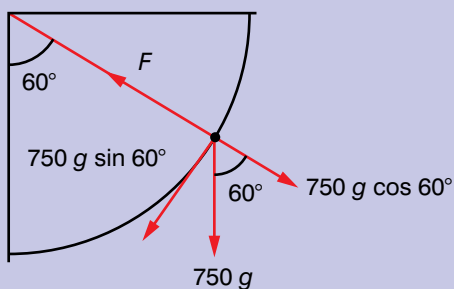

Figure 4.46

At this angle $F_N - mg \cos 60^\circ = mv^2/r$

$$\text{So } F_N = \frac{mv^2}{r} + mg \cos 60^\circ$$

Substituting in values for m etc:

$$\begin{aligned} F_N &= (750 \times 14^2/10) + (750 \times 9.8 \times 0.5) \\ &= 14\,700 + 3675 \\ &= 18\,375 \text{ N} \end{aligned}$$

Activity 4.21

Look at Figure 4.45. Consider the force T . How does it vary with the angle θ ?

Consider how the equations above vary with the angle θ .

Activity 4.22

Design your own simple fairground ride, giving details of the forces involved and any minimum speeds required.

What is a reasonable maximum force for riders to experience?

Project work

Prepare a presentation on the applications of dynamics to an activity. Choose an activity such as sports, any ball game, seat belts, rocket travel and apply what you have learnt in this unit to your chosen activity.

Summary

In this section you have learnt that:

- The maximum velocity of a vehicle going round a bend can be increased by banking the surface.
- The radial force on a body is constant when the body is in uniform horizontal motion.
- The radial force on a body varies when the body moves uniformly in a vertical circle.
- The dynamics of uniform circular motion and friction can be used to solve many problems.

Review questions

1. A fairground ride consists of a large vertical drum that spins so fast that everyone inside it stays pinned against the wall when the floor drops away. The diameter of the drum is 10 m. Assume that the coefficient of static friction between the drum and the rider's clothes is 0.15.
 - a) What is the minimum speed required for the riders so that they stay pinned against the inside of the drum when the floor drops away?
 - b) What is the angular velocity of the drum at this speed?
2. A person is trying to ride a bike all the way round the inside of a pipe for a stunt in a film. The filmmaker wants to know what speeds are involved. The pipe has a diameter of 8 m. The mass of the bike and rider is 400 kg. The rider goes at a constant speed of 5 m/s.
 - a) What is its acceleration at the bottom?
 - b) What is the force on the bike at an angle of 30° up from the bottom?
 - c) What is the minimum velocity at the top for the bike and rider to stay moving in a circle?
 - d) Do the bike and rider have sufficient velocity to stay moving on a circle at the top?

End of unit questions

- Construct a glossary of all the key terms in this unit. You could add it to the one you made for Units 1–3.
- How does the law of conservation of momentum relate to Newton's second law of motion?
- What is the difference between static friction and kinetic friction?
- A jet engine generates 160 kN of force as it propels a 20 000 kg plane down a runway. If 40 kN of friction opposes the motion of the plane, how much time will it take for the plane to reach a speed of 33 m/s from rest.
- A packing crate of weight 50 N is placed on a plane inclined at 35° from the horizontal. If the coefficient of static friction between the crate and the plane is 0.65, will the crate slide down the plane?
- How does friction affect the maximum velocity of a car going round a bend?
- Four billiard balls, each of a Mass 0.5 kg, are all travelling in the same direction on a billiard table, with speeds 2 m/s, 4 m/s, 8 m/s and 10 m/s. What is the linear momentum of this system?
- A 60 kg man standing on a stationary 40 kg boat throws a 0.2 kg ball with a velocity of m/s. Assuming there is no friction between the man and the boat, what is the speed of the boat after the man throws the ball?
- A spaceship moving at 1000 m/s releases a satellite of mass 1000 kg at a speed of 10 000m/s. What is the mass of the spaceship if it slows down to a velocity of 910 m/s?
- The drawing in Figure 4.43 represents the steering wheel of a car. The driver exerts two equal and opposite forces on it as shown.

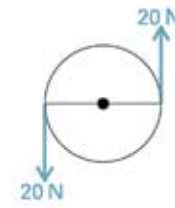

Figure 4.43

Will the wheel be in equilibrium? Explain your answer.

- A roller coaster goes through a vertical loop. When are the forces on the riders:
 - the smallest?
 - the greatest?

Contents	
Section	Learning competencies
5.1 Work as a scalar product (page 99)	<ul style="list-style-type: none"> Differentiate between energy, work and force.
5.2 Work done by a constant and variable force (page 101)	<ul style="list-style-type: none"> Describe and explain the exchange among potential energy, kinetic energy and internal energy for simple mechanical systems, such as a pendulum, a roller coaster, a spring, a freely falling object.
5.3 Kinetic energy and the work–energy theorem (page 103)	<ul style="list-style-type: none"> Identify the relationship between work and change in kinetic energy. Analyse and explain common situations involving work and energy, using the work–energy theorem.
5.4 Potential energy (page 107)	<ul style="list-style-type: none"> Determine the energy stored in a spring. Describe and explain the exchange among potential energy, kinetic energy and internal energy for simple mechanical systems, such as a pendulum, a roller coaster, a spring, a freely falling object.
5.5 Conservation of energy (page 111)	<ul style="list-style-type: none"> Predict velocities, heights and spring compressions based on energy conservation. Apply the law of mechanical energy conservation in daily life situations. Describe and explain the exchange among potential energy, kinetic energy and internal energy for simple mechanical systems, such as a pendulum, a roller coaster, a spring, a freely falling object. Solve problems involving conservation of energy in simple systems with various sources of potential energy, such as springs.
5.6 Conservative and dissipative forces (page 114)	<ul style="list-style-type: none"> Distinguish between conservative and non-conservative forces. Analyse situations involving the concepts of mechanical energy and its transformation into other forms of energy according to the law of conservation of energy.
5.7 Power (page 116)	<ul style="list-style-type: none"> Define and work out power.

You have met the concepts of energy and work before in Grade 9. An understanding of energy is essential to many things you use every day.

5.1 Work as a scalar product

By the end of this section you should be able to:

- Differentiate between energy, work and force.

KEY WORDS

work the product of displacement and the force in the direction of the displacement. It is measured in joules.

You covered the concept of work in Grade 9. You do **work** whenever you move a displacement when exerting a force in the direction of the displacement. Work done is defined as the magnitude of the force exerted in the direction of the displacement (or distance moved) multiplied by the displacement.

Remember that the unit of energy is the joule.

$$1 \text{ joule} = 1 \text{ newton} \times 1 \text{ metre}$$

So 1 joule is the work done when a force of 1 newton moves through a distance of 1 metre. This is the definition of the joule.

Here is a worked example to remind you.

Worked example 5.1

The girl in Figure 5.1 is lifting a heavy box onto a table. She uses a force of 200 N. The top of the table is 1.2 m above the floor. How much work does she do?

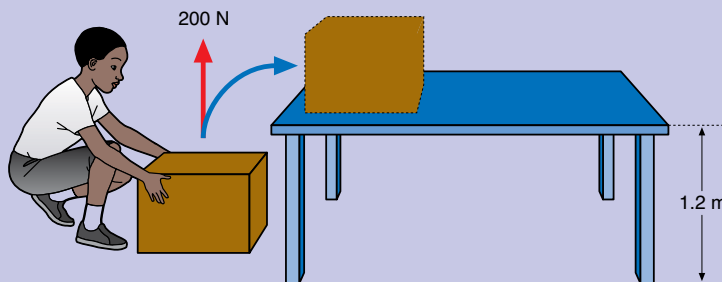

Figure 5.1 A girl lifting a heavy load

We know the force and the distance moved, so we can calculate the work done:

$$\begin{aligned} \text{work done} &= \text{force} \times \text{distance moved by the force} \\ &= 200 \text{ N} \times 1.2 \text{ m} = 240 \text{ J} \end{aligned}$$

So the girl does 240 J of work. We can also say that 240 J of energy has been transferred from the girl to the box.

The box has gained 240 J of potential energy because it is higher up than it was before.

Activity 5.1

In small groups, discuss the difference between carrying a box down a corridor and pushing the same box. What work is done in each case?

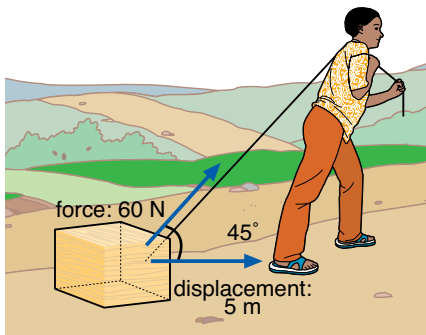

Figure 5.2 How much work is this man doing?

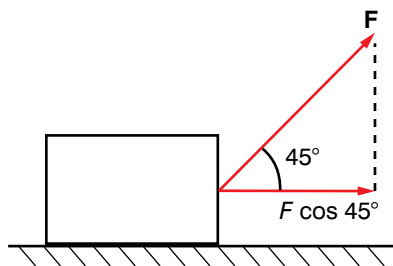

Figure 5.3

In the worked example on page 99, the girl is doing work against the force of gravity.

Both force and displacement moved are vectors. Work done is the scalar product of force and displacement:

$$W = \mathbf{F} \cdot \mathbf{d} = Fd \cos \theta$$

where F and d are the magnitudes of the vectors.

Work done is a scalar – it does not have directional properties.

Look at Figure 5.2. We can calculate the work done by the man in moving the box.

We can show the forces on a free body diagram (Figure 5.3).

The force in the direction of the displacement is $F \cos 45^\circ$, so work done is

$$W = Fd \cos \theta$$

which is the equation for the scalar product of the force and displacement vectors. In Unit 2, you learnt that the scalar product of two vectors can also be expressed as:

$$\mathbf{a} \cdot \mathbf{b} = a_x b_x + a_y b_y$$

where the vectors are given in component form and are $\mathbf{a} = \begin{bmatrix} a_x \\ a_y \end{bmatrix}$ and $\mathbf{b} = \begin{bmatrix} b_x \\ b_y \end{bmatrix}$.

Worked example 5.2

A box is attached to a rope, which runs over a pulley above the box. The man pulls the rope with a force of 75 N at an angle of 50° to the horizontal. The man raises the box 1.5 m. Use the scalar product to find the work done on the box.

Draw a free body diagram to show the forces (Figure 5.4).

In component form, the force is: $\mathbf{F} = \begin{bmatrix} 48.21 \\ 57.45 \end{bmatrix}$ and the

displacement is $\mathbf{d} = \begin{bmatrix} 0 \\ 1.5 \end{bmatrix}$.

The work done is:

$$W = \mathbf{F} \cdot \mathbf{d} = (48.21 \times 0) + (57.45 \times 1.5) = 0 + 86.175 = 86.175 \text{ J}$$

Alternatively you could work out the work done using the formula involving the angle between the vectors. Figure 5.4 shows that this angle is 40° . So the work done is:

$$\begin{aligned} W &= Fd \cos 40^\circ \\ &= 75 \text{ N} \times 1.5 \text{ m} \times \cos 40^\circ \\ &= 75 \text{ N} \times 1.5 \text{ m} \times 0.766 \\ &= 86.175 \text{ J} \end{aligned}$$

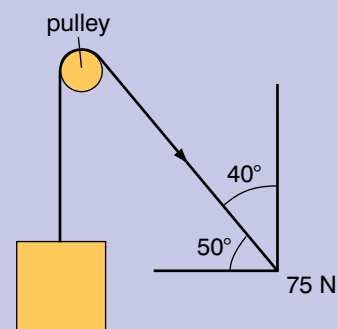

Figure 5.4

In this worked example, note that the angle between the vectors is 40° , as shown in Figure 5.4.

Summary

In this section you have learnt that:

- Work done is the scalar product of the force and displacement vectors.

Review questions

1. A water container is dragged up a slope. The displacement is $\begin{bmatrix} 5 \\ 1 \end{bmatrix}$ metres and the force used is $\begin{bmatrix} 50 \\ 25 \end{bmatrix}$ N.
What is the total work done?
2. A man drags a box $\begin{bmatrix} 20 \\ -1 \end{bmatrix}$ m with a force of $\begin{bmatrix} 35 \\ 25 \end{bmatrix}$ N.
How much work does the man do on the box?

5.2 Work done by a constant and variable force

By the end of this section you should be able to:

- Describe and explain the exchange among potential energy, kinetic energy and internal energy for simple mechanical systems, such as a pendulum, a roller coaster, a spring, a freely falling object.

Work is a term that you will already be familiar with both in everyday use and from your earlier studies of physics. The way we use the word 'work' in physics is not the same as the way we use it in everyday life. We may say, for example, that it is hard work to sit at a desk and read this book, but in the physics sense no work is being done.

If we are to do work in the physics sense, two things must happen. They are:

- we must exert a force
- while exerting the force, we must move a distance in the direction of the force.

These conditions are met when we slide a piece of furniture across a rough floor (we do work against the opposing force of friction), when we lift a heavy object off the ground (doing work against the opposing force of gravity) or when we stretch a spring (doing work against the tension in the spring as it tries to contract again).

Activity 5.2

You are going to pull a block up a slope and find the work done in pulling the block up the slope.

- Arrange a wooden board to form a slope at an angle of about 30° to the horizontal.
- Place a block of wood on the slope and attach a newtonmeter.
- Pull the block slowly up the slope and record the force needed to pull the block. Try to pull the block with a constant force – you may need to practise a couple of times.
- Measure the length of the slope.
- Calculate the work done in moving the block up the slope.
- Also record the vertical height of the slope and the mass of the block – you will need this for Activity 5.7 on page 115.

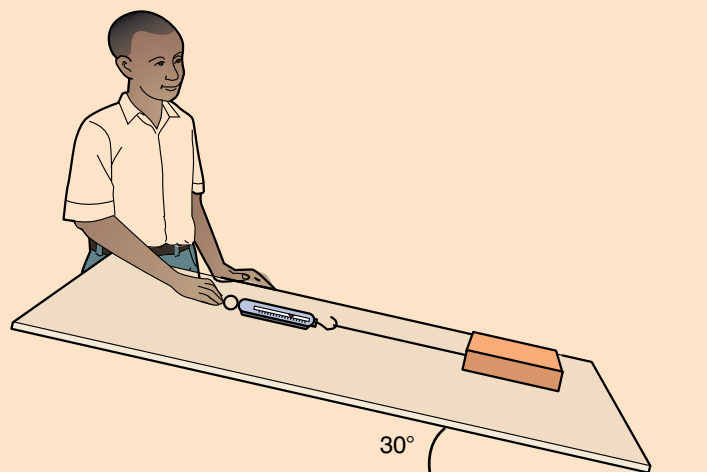

Figure 5.5 Doing work: pulling a block up a slope

Variable force

So far we have only dealt with constant forces. In practice many forces are not constant. For example, when a driver changes the position of an accelerator pedal in a vehicle, the driving force of the engine is changed. Drivers do not keep the accelerator pedal in the same position but vary it – so the force being applied is not constant.

We cannot use the equation $\text{work done} = \text{force} \times \text{distance moved}$ when the force varies – this equation needs the force to be constant. However, if we can find the average force used, then we can calculate the amount of work done using the equation.

In Unit 2, you learnt that when you plot a graph of velocity against time, the area under the graph is the displacement. The same principle applies when we draw a graph of force against displacement.

When a force is constant, the graph will be a horizontal straight line, as shown in Figure 5.6. The work done is $5 \text{ N} \times 10 \text{ m} = 50 \text{ N m}$.

When a force varies, we cannot use the equation work done = force \times distance moved. But the relationship for the area under the graph is still true. If we are able to record the force used and the displacement and plot a graph, we could find the work done by finding the area under the graph, as shown in Figure 5.7.

You could find an approximation to the area by breaking it down into thin vertical strips and finding the area of each strip. However, if you know the average force or can find an estimate of it, you can estimate how much work has been done. The work done is then the average force multiplied by the displacement.

For example, look at Figure 5.7. You can estimate the average force by putting a ruler on top of the graph as though you were going to draw a horizontal line. Adjust the position of the ruler so that the area between the graph line and the ruler is about the same above the ruler as it is below the ruler – this will give you an estimate of the average force.

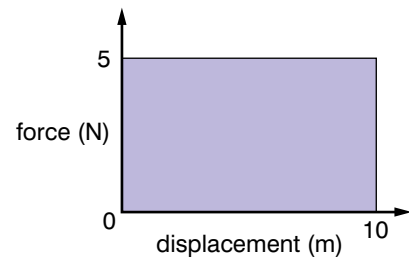

Figure 5.6 Graph of force against displacement for a constant force

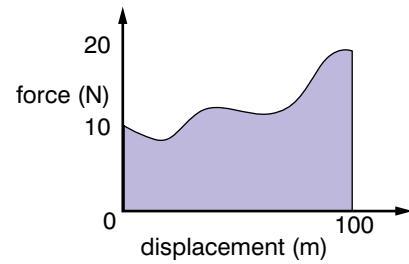

Figure 5.7 Graph of force against displacement for a variable force

Summary

In this section you have learnt that:

- Work, energy and force are different things.
- When a force varies, you can calculate the work done directly if you know the average force exerted.
- Work done by a force can be calculated from the area under a graph of force against displacement.

Review question

1. Imagine that you have dragged a heavy box 100 m. Draw a graph of force against distance to show how the force might vary with distance.

5.3 Kinetic energy and the work–energy theorem

By the end of this section you should be able to:

- Identify the relationship between work and change in kinetic energy.
- Analyse and explain common situations involving work and energy, using the work–energy theorem.

Energy is not an easy concept. You may associate energy with motion, but not all forms of energy involve motion. For example, potential energy is based on the position or configuration of an

KEY WORDS

energy the amount of work that can be performed by a force; it is a scalar quantity and is measured in joules

KEY WORDS

kinetic energy *the energy that a moving object has. The faster an object is moving, the more energy it has.*

REMEMBER

Remember that friction is not a form of energy – it is a force. You have to exert a force to overcome the static friction and then the kinetic friction once the object is moving. So you have to do work against the force, and work is done to achieve this.

Discussion activity

In small groups discuss the following questions.

- What are positive work and negative work?
- What effect do they have on the kinetic energy of a body?
- What forms can energy take and how can it be transformed between these different forms?

Report your conclusions back to the rest of the class.

object. You can measure most forces that cause work to be done and you can measure the displacement of the object that was caused by the force, but you cannot measure the energy directly. You need to multiply together the two quantities that you can measure (force and displacement) to find the work done or energy.

In Grade 9 you learnt about **kinetic energy** and the work–energy theorem. All moving objects have kinetic energy – the amount of energy is related to the velocity of the object. Kinetic energy is given by the equation:

$$E_k = \frac{1}{2}mv^2$$

where E_k is the kinetic energy of the object, m is the mass of the object and v is the magnitude of the velocity of the object. Even though velocity is a vector, kinetic energy is a scalar quantity.

The work–energy theorem states that if the kinetic energy of an object changes because of a force acting on the body, the mechanical work is the difference in kinetic energy. It is given by the equation:

$$W = \Delta E_k = E_{k2} - E_{k1} = \frac{1}{2}m(v_2^2 - v_1^2)$$

where W is the work done, ΔE_k is the change in kinetic energy, E_{k2} and E_{k1} are the kinetic energies after and before the force acts, respectively, and v_2 and v_1 are the velocities of the body after and before the force acts.

We can derive the work–energy theorem from Newton’s second law of motion. We will use the direction of the force as a frame of reference, as shown in Figure 5.8. A force F acts on a body of mass m over a distance s . At displacement 0, the velocity is v_1 and at displacement s , the velocity is v_2 .

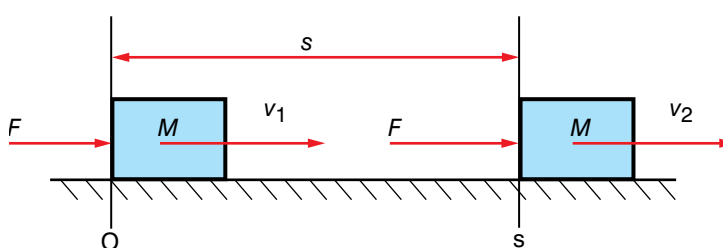

Figure 5.8 A constant force acting on a body over a distance s

According to Newton’s second law of motion:

$$F = ma$$

We can use the equation of motion $v^2 = u^2 + 2as$ to find an expression for a and substitute this into the equation for Newton’s second law:

$$v_2^2 = v_1^2 + 2as$$

$$2as = v_2^2 - v_1^2$$

$$a = (v_2^2 - v_1^2)/2s$$

So the force acting on the body is:

$$F = m(v_2^2 - v_1^2)/2s$$

Now the work done on the body is:

$$W = Fs = \frac{m(v_2^2 - v_1^2)}{2s} \times s = \frac{1}{2}mv_2^2 - \frac{1}{2}mv_1^2$$

Worked example 5.3

A boy throws a ball. The ball leaves the boy's hand with a velocity of 16 m/s and has a mass of 200 g.

Assuming that the boy's hand moved through 1.2 m when throwing the ball, what is the average force the boy applied to the ball?

As the ball was at rest, the work done on the ball is the kinetic energy of the ball, according to the work–energy theorem.

Kinetic energy of ball, $E_k = \frac{1}{2}mv^2$

$$E_k = Fd$$

$$\text{So } F = E_k/d = \frac{1}{2}mv^2/d$$

Substituting the values into the equation:

$$F = \frac{1}{2} \times 0.2 \text{ kg} \times 16^2 \text{ m}^2/\text{s}^2 / 1.2 \text{ m} = 21.3 \text{ N}$$



Figure 5.9 Energy is transferred to the ball when it is thrown.

In the worked example above, the action of the force by the boy's hand on the ball transferred energy from the boy to the ball (Figure 5.9).

Worked example 5.4

A car of mass 1250 kg is travelling at a velocity of 15 m/s due East. The driver applies the brakes to slow the car down to a velocity of 3 m/s due East.

- What is the work done in slowing the car down?
- Assume that the car took 3 seconds to slow down. What was the force of the brakes?

First draw a diagram to show the velocities (Figure 5.10).

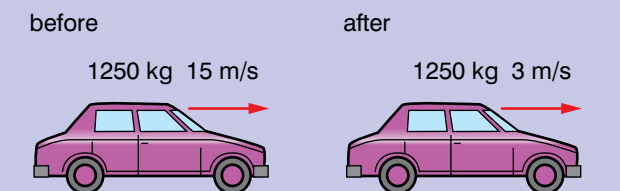

Figure 5.10

- Using the equation above:

$$W = \frac{1}{2}m(v_2^2 - v_1^2)$$

Substituting in the values:

$$W = \frac{1}{2} \times 1250(3^2 - 15^2) = \frac{1}{2} \times 1250 \times -216 = -135\,000 \text{ J}$$

- Use Newton's second law:

$$F = ma$$

Work out the acceleration from the initial and final velocities and the time taken for the change in speed:

$$a = (v - u)/t$$

$$\text{So } F = m(v - u)/t$$

Substituting in the values:

$$\begin{aligned} F &= 1250 \text{ kg} \times (3 \text{ m/s} - 15 \text{ m/s}) \div 3 \text{ s} \\ &= 1250 \text{ kg} \times -12 \text{ m/s} \div 3 \text{ s} \\ &= -5000 \text{ N} \end{aligned}$$

The minus sign means that the force is acting to the left, opposite to the direction the car is travelling in.

In the worked example 5.4, as the car is being slowed down, the acceleration is in a direction opposite to that in which the car is travelling. This also means that the force is in the opposite direction and so negative work is done, because the mechanical energy of the car has decreased.

Also, it was assumed that the car was travelling along a flat road. If the road was sloping, the mechanical energy of the car would also have been changing because of the force due to gravity as well as the force from the brakes.

When this book is sitting on a table, the force of gravity is acting on the book and there is a force of mg being exerted upwards by the table on the book. But no work is done by the table on the book because no energy is transferred into or out of the book.

Project: mousetrap car

You are going to make a toy car powered by a mousetrap that will go the greatest distance, have the highest speed or highest average speed.

In Grade 9 you made a car using a mousetrap – you built a car that was powered only by the spring of a mousetrap (Figure 5.11). Here you are going to have another go.

Can you improve your design so that your car does better?

Can you make your car go the greatest distance, have the highest speed or highest average speed?

Remember that your car may not work well at first. You will need to test your car to see how well it works – you will then probably want to make improvements to your design.

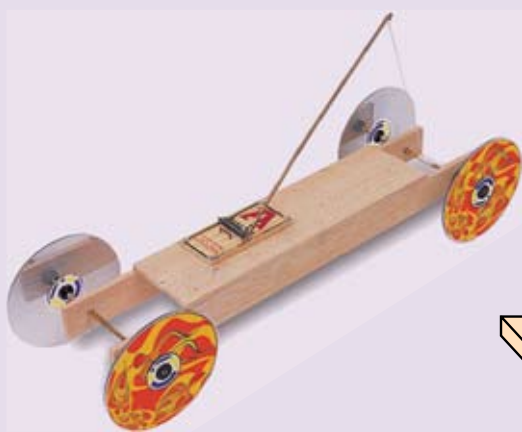

Figure 5.11 A mousetrap car

Basic design

The car makes use of the spring in the mousetrap. You attach one end of a piece of string to the 'snapper' part of the mousetrap. The other end of the string is attached to the drive axle of your car by a hook. You then wind the string round the drive axle by turning the wheels backwards so that the snapper arm is pulled back towards the axle (Figure 5.12).

When the drive wheels are released, the string is pulled off the drive axle by snapper moving forwards because of the spring of the mousetrap.

If you decide that you want to go for the highest speed, you need the energy stored in the spring to be released quickly. If you want to go for the longest distance, you need the energy stored in the spring to be released slowly.

The record for the longest distance a mousetrap car has travelled is over 180 metres!

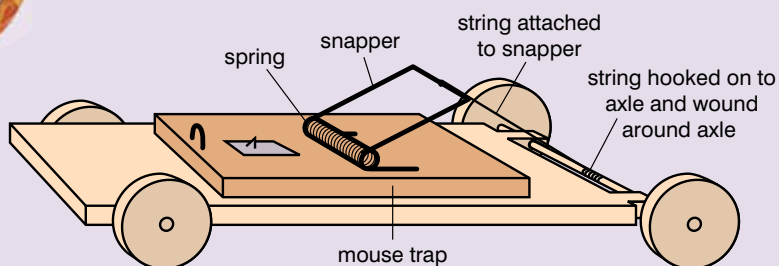

Figure 5.12 Principle of how a mousetrap car works

Summary

In this section you have learnt that:

- The work–energy theorem can be derived from Newton’s second law of motion.

Review questions

1. A football of mass 550 g is at rest on the ground. The football is kicked with a force of 108 N. The footballer’s boot is in contact with the ball for 0.3 m.
 - a) What is the kinetic energy of the ball?
 - b) What is the ball’s velocity at the moment it loses contact with the footballer’s boot?
2. A car of mass 1200 kg accelerates from 5 m/s to 15 m/s. The force of the engine acting on the car is 6000 N.
Over what distance did the force act?

5.4 Potential energy

By the end of this section you should be able to:

- Determine the energy stored in a spring.
- Describe and explain the exchange among potential energy, kinetic energy and internal energy for simple mechanical systems, such as a pendulum, a roller coaster, a spring, a freely falling object.

You do work when you push or pull something against a force that is opposing you. When you stop pulling or pushing, does the system tend to fly back to its original position if you let it? If so, then at least some of the energy you have fed in must have been stored as potential energy. **Potential energy** tends to get released as the system returns to its original state. Some examples of where energy is stored as potential energy are gravitational potential energy and elastic potential energy.

When you raise something from the floor to a high shelf, the object gains gravitational potential energy. You have forced the object and the Earth apart against their gravitational attraction. If you let them, the two will pull each other back together – in other words, the object will fall back to the ground.

When you compress or stretch a spring or bend a bow to fire an arrow, energy is stored as elastic potential energy.

When you lift something, you do work on it against the force of gravitational attraction. The energy gained by the object is the force multiplied by the distance moved. We can express this in a slightly

KEY WORDS

potential energy *the energy possessed by an object because of its position or configuration. Its units are joules.*

Discussion activity

How can you use the fact that work is the scalar product of force and displacement to explain that no work is done when you carry a box at the same height, but work is done if you change the object's height?

Can you also use this to explain negative work?

Worked example 5.5

A boy climbs a flight of stairs. His mass is 65 kg and the displacement is $\begin{bmatrix} 4 \\ 4 \end{bmatrix}$ m.

How much potential energy has he gained?

Vertical distance is 4 m.

Gain in gravitational potential energy

$$= 65 \text{ kg} \times 9.8 \text{ m/s}^2 \times 4 \text{ m} \\ = 2548 \text{ J}$$

Discussion activity

How does your choice of frame of reference affect the amount of gravitational energy an object appears to have?

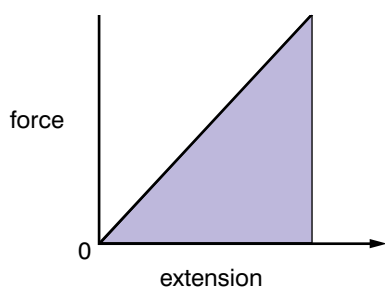

Figure 5.14

different way. The force is the mass of the object multiplied by the acceleration due to gravity. The distance moved is the increase in height.

$$\text{So work done, } W = mg\Delta h$$

The work done is energy and we say that the object has gained gravitational potential energy. So we can say that the gain in gravitational potential energy is given by the equation:

$$\text{GPE} = mg\Delta h$$

Activity 5.3

You are going to find out how much a spring stretches when masses are hung on it. Use different masses and measure the extension.

The basic set up for the apparatus is shown in Figure 5.13.

Plan your experiment.

What are you going to measure?

How will you measure it?

What will you do to make your results more reliable?

Can you find a relationship between the length of the spring and the mass that you hang on the end of it?

Make a prediction of what the length of the spring will be when you hang a certain mass on it. Hang the mass on the spring and see if your prediction is correct.

Write a report of your experiment using the writing frame in Unit 1.

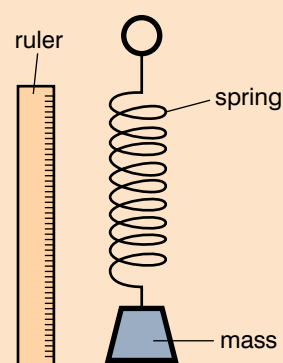

Figure 5.13

You should have found from Activity 5.3 that there is a linear relationship between the force on the spring and the extension of the spring. The expression is:

$$F = -kx$$

where F is the force on the spring, x is the extension of the spring and k is the spring constant.

Figure 5.14 shows a graph of the force on a spring against the extension of the spring. Extension is the same as distance – in Section 5.2 we saw that the area under the graph is the work done. In Figure 5.14, this is the amount of work done on the spring to stretch it by a certain distance. This is also the amount of energy stored in the spring.

So the energy stored in a spring can be written as the area of the triangle which is

$$E = \frac{1}{2}Fx$$

From before $F = kx$, so

$$E = \frac{1}{2}kx \times x = \frac{1}{2}kx^2$$

Worked example 5.6

A mass of 125 g is attached to a horizontal spring that sits on a frictionless surface. One end of the spring is attached to a block that is massive. The spring is stretched by 10 cm and the spring constant is 200 N/m.

- How much energy is stored in the spring?
 - The mass is let go. What is the highest velocity of the mass?
- a) First draw a diagram to show all of the variables.

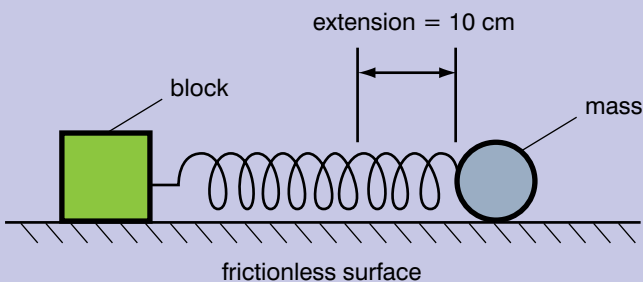

Figure 5.15

The energy stored in the spring is given by the equation

$$E = \frac{1}{2}kx^2$$

Substituting in the values:

$$E = \frac{1}{2} \times 200 \text{ N/m} \times (0.1 \text{ m})^2 = 1 \text{ J}$$

- When the mass is let go, the spring will contract and the mass will move.

When the mass is moving the fastest, all of the stored energy will have been transferred to kinetic energy.

Use the equation $E = \frac{1}{2}mv^2$

$$\text{So } v^2 = 2E/m$$

$$\text{and } v = \sqrt{(2E/m)}$$

Substituting in the values:

$$v = \sqrt{(2 \times 1 \text{ J} \div 0.125 \text{ kg})} = \sqrt{(16 \text{ m}^2/\text{s}^2)} = 4 \text{ m/s}$$

Activity 5.4

- Describe the energy changes that take place as a roller coaster goes from its starting position, up to the top of the first slope, then down the slope and round a loop-the-loop.

Will the roller-coaster keep all its mechanical energy?
Explain why or why not.

- A spring is set up with a mass hanging from it like you used in Activity 5.3. The mass is pulled down and then let go. The mass oscillates up and down.

Describe the energy changes that are taking place in the mass and spring as it oscillates.

Summary

In this section you have learnt that:

- Gravitational potential energy is given by the equation $GPE = mg\Delta h$, where Δh is the change in height.
- The extension x of a spring is given by the equation $F = kx$, where F is the force and k is the spring constant.
- The energy stored in a spring is given by the equation $E = \frac{1}{2}kx^2$, where k is the spring constant and x is the extension.
- In an oscillation, energy is transferred between potential energy and kinetic energy.

Review question

- a) A boy walks up a hill. His displacement from his starting point is (800, 150) m.
How much gravitational potential energy has he gained?
 - b) The boy then walks to a village. The displacement from his starting point is (400, -50) m.
How much gravitational potential energy did he lose going from the top of the hill to the village?
 - c) What was the boy's net change in gravitational potential energy from his starting point to the village?
2. A spring has a spring constant of 75 N/m. It is stretched by 20 cm.
How much energy is stored in the spring?
3. A force of 40 N is used to stretch a spring which has a spring constant of 350 N/m.
How much energy is stored in the spring?
4. A spring has a spring constant of 150 N/m and a mass is 100 g is attached to it. The spring sits on a horizontal frictionless surface and the other end of the spring is attached to a solid block.
The mass is pulled by 10 cm to stretch the spring and then let go.
What is the highest velocity of the mass?

5.5 Conservation of energy

By the end of this section you should be able to:

- Predict velocities, heights and spring compressions based on energy conservation.
- Apply the law of mechanical energy conservation in daily life situations.
- Describe and explain the exchange among potential energy, kinetic energy and internal energy for simple mechanical systems, such as a pendulum, a roller coaster, a spring, a freely falling object.
- Solve problems involving conservation of energy in simple systems with various sources of potential energy, such as springs.

In Grade 9, you learnt about the law of conservation of energy, which states that energy cannot be created or destroyed. It can only be changed from one form to another.

In a system the mechanical energy of the system stays constant unless there is a force such as friction acting on the system. The total mechanical energy is:

$$E = U + E_k$$

where E is the total mechanical energy, E_k is the kinetic energy and U is the potential energy. The potential energy can be gravitational potential energy or energy stored in a spring, for example.

When a spring is stretched, work is done because a force has been used to move one end of the spring by a certain displacement. Work is also done against gravity when you walk up stairs and you gain gravitational potential energy. When you walk down stairs, work is done by gravity and you lose gravitational potential energy.

We can show this as:

Work done against gravity, $W = \Delta U$

Work done by gravity, $W = -\Delta U$

In Unit 3, we used the equations of motion to solve the problem of how high a ball will go before falling back to earth when it is thrown into the air. We can use the law of conservation of energy to help us solve the same problem.

When a ball is thrown into the air, all of its energy is kinetic energy. As the vertical component of the ball's velocity decreases, its total kinetic energy decreases. Some of the kinetic energy is transferred to gravitational potential energy. When the ball reaches its maximum height, all of the kinetic energy from the vertical component of the ball's velocity has been transferred to potential energy.

Activity 5.5: Energy changes in a pendulum bob

You are going to explore the energy changes in a pendulum bob as it swings to and fro.

Set up a pendulum by attaching it securely to a support bar. Mount a metre stick horizontally, as shown in Figure 5.16. Hold the pendulum bob to one side as shown and let the bob go.

What happens to the bob? Where does the bob reach on the other side?

What is happening to the energy of the bob as it swings backwards and forwards?

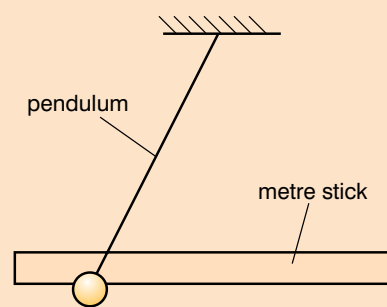

Figure 5.16 Pendulum for Activity 5.5

Worked example 5.7

A ball is thrown with a velocity of 20 m/s at an angle of 20° to the horizontal. The mass of the ball is 200 g.

What is the maximum height reached by the ball?

Draw a diagram to show the ball's path (Figure 5.17).

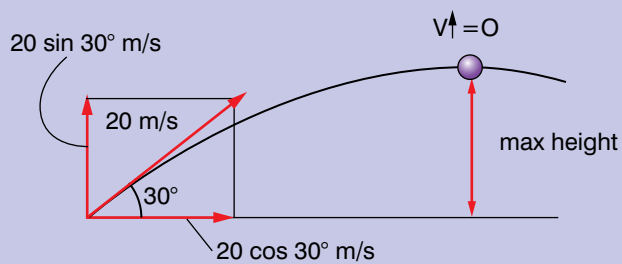

Figure 5.17

Resolve the velocity of the ball into horizontal and vertical components.

$$\mathbf{v} = \begin{bmatrix} 20 \cos 30^\circ \\ 20 \sin 30^\circ \end{bmatrix}$$

When the ball is thrown, the kinetic energy of the vertical component of its velocity is:

$$KE = \frac{1}{2}mv_y^2$$

At the maximum height, all of this energy is transferred to gravitational potential energy:

$$GPE = mg \Delta h$$

$$\text{So } mg\Delta h = \frac{1}{2}mv_y^2$$

$$\Delta h = \frac{1}{2}v_y^2/g$$

Substituting in the values:

$$\begin{aligned} \Delta h &= \frac{1}{2}(20 \sin 30^\circ)^2/9.8 \\ &= 5.1 \text{ m} \end{aligned}$$

Worked example 5.8

A 2 kg mass hangs from a piece of rope of length 3 m. It is pulled out on one side a perpendicular distance of 0.5 m and let go.

What is the velocity of the mass as it passes through the lowest point?

First draw a diagram (Figure 5.18).

The lowest point is when the mass is at A. We need to work out the height that the mass falls during its swing. This is the height of B above A.

Using Pythagoras' theorem, $x^2 = 9 - 0.25 = 8.75$

$$\text{So } h = 3 - \sqrt{8.75}$$

Gravitational potential energy at B = mgh

Kinetic energy at A = $\frac{1}{2}mv^2$

As the mechanical energy of the system does not change (we can ignore the effects of air resistance):

$$\frac{1}{2}mv^2 = mgh$$

$$v^2 = 2gh$$

Substituting the values into the equation:

$$\begin{aligned} v^2 &= 2 \times 9.8 \times (3 - \sqrt{8.75}) \text{ m}^2/\text{s}^2 \\ &= 0.822 \text{ m}^2/\text{s}^2 \end{aligned}$$

$$\text{So } v = \sqrt{0.822} \text{ m/s} = 0.91 \text{ m/s}$$

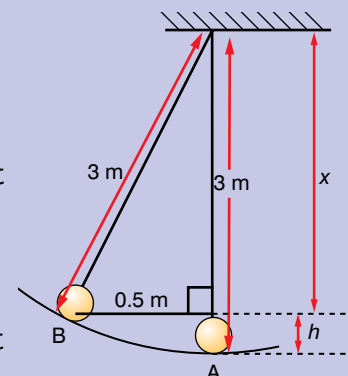

Figure 5.18

Collisions

In Unit 4 you learnt about elastic and inelastic collisions and that momentum is conserved in all collisions. Kinetic energy is not conserved in all collisions. If the collision is elastic, kinetic energy is conserved. If the collision is inelastic, kinetic energy has not been conserved.

Worked example 5.9

Two roads are perpendicular and meet at a junction.

Car A of mass 1000 kg travels along one road at 20 m/s due North.

Car B of mass 1300 kg, travels due West along the other road at 16 m/s.

At the junction the cars collide and move together with a velocity of $\begin{bmatrix} 9.04 \\ 8.70 \end{bmatrix}$ m/s.

Is the collision elastic or inelastic?

We need to work out the kinetic energies of the cars before and after collision.

$$\begin{aligned} \text{KE of car A} &= \frac{1}{2}mv^2 = \frac{1}{2} \times 1000 \times 20^2 \\ &= 200\,000 \text{ J} \end{aligned}$$

$$\text{KE of car B} = \frac{1}{2} \times 1300 \times 16^2 = 166\,400 \text{ J}$$

$$\begin{aligned} \text{Total KE of cars before collision} \\ &= 200\,000 + 166\,400 = 366\,400 \text{ J} \end{aligned}$$

Use Pythagoras to find the magnitude of velocity of two cars after collision:

$$v^2 = 9.04^2 + 8.70^2$$

KE of two cars after collision

$$\begin{aligned} &= \frac{1}{2} \times (1000 + 1300) \times (9.04^2 + 8.70^2) \\ &= 181\,023 \text{ J} \end{aligned}$$

The collision is inelastic because kinetic energy has not been conserved.

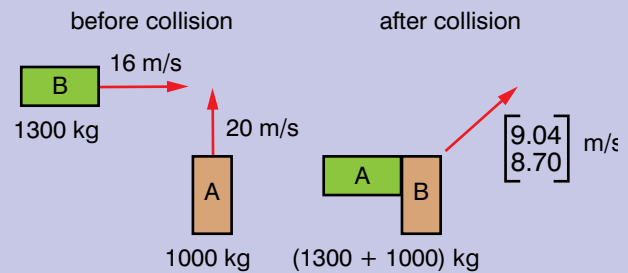

Figure 5.19

Summary

In this section you have learnt that:

- The law of conservation of energy states that energy cannot be created or destroyed.
- The law of conservation of energy can be used to solve problems involving kinetic and potential energy.
- Kinetic energy is conserved in an elastic collision, but not in an inelastic collision.

Review questions

1. A ball of mass 500 g is kicked into the air at an angle of 45° . It reaches a height of 12 m.
What was its initial velocity?
2. A pendulum bob has a mass of 1 kg. The length of the pendulum is 2 m. The bob is pulled to one side to an angle of 10° from the vertical.
 - a) What is the velocity of the pendulum bob as it swings through its lowest point?
 - b) What is the angular velocity of the pendulum bob?
3. A pool ball of mass 100 g and velocity $\begin{bmatrix} 5 \\ -4 \end{bmatrix}$ m/s collides with a stationary pool ball of the same mass. After the collision, the pool balls have velocities $\begin{bmatrix} 2 \\ -3 \end{bmatrix}$ m/s and $\begin{bmatrix} 3 \\ -1 \end{bmatrix}$ m/s. Is the collision elastic? Explain your answer.

5.6 Conservative and dissipative forces

By the end of this section you should be able to:

- Distinguish between conservative and non-conservative forces.
- Analyse situations involving the concepts of mechanical energy and its transformation into other forms of energy according to the law of conservation of energy.

Activity 5.6

One student picks up a book from a desk and places it directly on a high shelf. A second student picks up a book from the same desk, walks away briefly from the desk before putting it on the high shelf. A third student picks up a book from the same desk, walks around the classroom several times and then places it on the high shelf.

Which book has had more work done on it? Why?

Discuss in small groups and report back to the rest of the class.

The mechanical energy of a system is the sum of the potential energy and the kinetic energy of the system. Some forces cause mechanical energy to be lost from a system, whereas others do not.

Look at Figure 5.20a. Suppose you pick up the pen from the table and move it through the air. You then put the pen back on the table in the same place. What can you say about the work done on the pen? It is zero (we are assuming that there is no friction from the air). The force on the pen is the gravitational attraction of the Earth. The pen gained some gravitational potential energy when it was lifted up off the table. It then lost this gravitational potential energy when it was put back on the table.

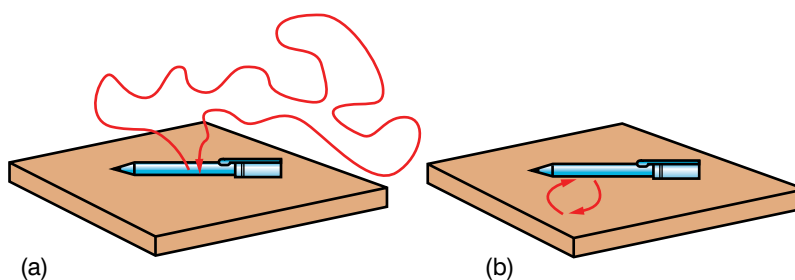

Figure 5.20 Conservative (a) and dissipative (b) forces

Look at Figure 5.20b. Suppose you push the pen across the table and then push it back again to its original position. In this case work has been done on the pen, because you had to apply a force to push the pen across the table. The force is due to friction between the table and the pen.

The first example is an example of a **conservative force**. Gravity is an example of a conservative force. It does not matter which path you take – it is the vertical distance that determines whether you have gained or lost gravitational potential energy. If you return to the same place, the net change in your gravitational potential energy is zero. A spring is another example of something that exerts a conservative force.

The second example showed a **dissipative force**. When you push the pen across the table, you have to do work to overcome the frictional force. When you return the pen to its original place, there has been some work done on the pen, and it has lost mechanical energy because of the frictional force. Another example of a dissipative force is drag caused by the air.

In the absence of friction, mechanical energy is conserved. When friction is present, mechanical energy is not conserved and the mechanical energy lost is equal to the work done against friction.

We can express this in the following relationship:

$$W_{nc} = E_f - E_i$$

where W_{nc} is the work done by non-conservative forces, E_f is the final energy of the system and E_i is the initial energy of the system.

When a block is dragged over a surface, W_{nc} is the work done by a force in overcoming the friction of the surface to move the block through a displacement d .

Summary

In this section you have learnt that:

- When a conservative force acts on a body, the work done is independent of the path taken by the body.
- Springs and gravity are examples of conservative forces.
- A dissipative force causes mechanical energy to be lost from a body when it is moving.
- Friction is an example of a dissipative force.

Review question

1. What are the differences between conservative and dissipative forces?

KEY WORDS

conservative force *a force that does no work when a body moves on a closed path*

dissipative force *a force that does work when a body moves on a closed path*

Activity 5.7

Look at your results from Activity 5.2 earlier in this unit.

- Work out how much gravitational potential energy the block will have gained at the top of the slope.
- What was the work done in moving the block?
- Why is this different to the gain in gravitational potential energy?
- What else can you work out from your results?

Discussion activity

What examples of conservative and dissipative forces can you think of? Justify why you think each force is conservative or dissipative.

KEY WORDS

power *the rate at which work is done or energy is expended. Its units are watts.*

Worked example 5.10

An engine raises a load of 100 kg from a mine that is 300 m deep in 2 minutes.

What is the power of the engine?

The force needed to lift the load is:

$$\text{force} = \text{weight of load} = 100 \text{ kg} \times 9.8 \text{ m/s}^2 = 980 \text{ N}$$

Calculate the work done in raising the load:

$$\begin{aligned} \text{work done} &= \text{force} \times \text{distance} \\ &= 980 \text{ N} \times 300 \text{ m} = 294\,000 \text{ N} \end{aligned}$$

Calculate the power:

$$\text{power} = \frac{\text{work done}}{\text{time taken}}$$

$$\text{time taken} = 2 \times 60 = 120 \text{ seconds}$$

$$\text{power} = 294\,000/120 = 2450 \text{ W}$$

Project work

Investigate what the major source of energy used in houses in your area is. Is there more than one main source?

Write a report on your findings.

5.7 Power

By the end of this section you should be able to:

- Define and work out power.

In Grade 9, you learnt about **power**. As for work and energy, the term power as has a different meaning in physics to its meaning in everyday life. We can describe a truck as powerful, but we really mean that it is capable of exerting a large force.

Power is the rate at which work is done, or the work done per second. It is measured in the units joules per second (j/s), which are also called watts (W).

$$\text{power} = \frac{\text{total work done}}{\text{total time taken}}$$

Activity 5.8

You are going to find the power of your arm muscles.

You do work when you lift an object, because you have to move the box upwards – you are doing work against gravity. The faster you move the box, the greater your power.

- Find the mass of the object.
- Hold the object in one hand and put your arm down by your side.
- Lift the weight up above your head so that your arm is stretched vertically above your head.
- Drop your arm by your side.
- Repeat nine times.
- Use a stopwatch to measure the time it takes you to raise and lower the object ten times.
- Measure the vertical distance you move the object through.
- Calculate the work done.
- Calculate your power ($= \frac{\text{work done}}{\text{time taken}}$)
- What time should you use to work out your power? Why do you think this?

Summary

In this section you have learnt that:

- Power = work done \div total time taken.

Review questions

- A weightlifter lifts 200 kg through 1.8 m in 2 s.
 - What is the weightlifter's power?
 - Why is his actual power likely to be higher than this?
- A petrol engine raises 200 litres of water in a well from a depth of 7 m in 6 seconds. Show that the power of the engine is about 2330 W.
- Look at question 1 on page 101 . It takes 4 seconds to drag the container up the slope. What is the power?
- Look at question 2 on page 101. The man takes 12 seconds to drag the box. What is his power?
- A spring with a spring constant of 275 N/m is stretched 20 cm in 2 seconds.
What is the power applied to stretch the spring?

End of unit questions

- Construct a glossary of all the key terms in this unit. You could add it to the one you made for Units 1–4.
- Figure 5.21 shows a smooth bowl XYZ. A ball is released from point X.
 - Describe how the ball will move.
 - What energy changes occur as the ball moves?
 - How would your answers to parts a) and b) be different if the surface of the ball was rough?
- Two children with the same mass climb a ladder to the top of a slide. One of them goes down the slide and returns to the base of the ladder. The other child comes back down the ladder. Has each child lost the same amount of energy? Explain your answer.
- What are the differences between work, energy and force?
- What energy changes take place in a stone that falls from a cliff?
- Dahnay carried a box (5, 4) m. The box had a mass of 5 kg. Dahnay says that over 300 J of work was done on the box. Is Dahnay correct? Explain your answer.
- How can you find the work done from a graph of force against displacement?
- How can you derive the work–energy theorem from Newton's second law of motion?

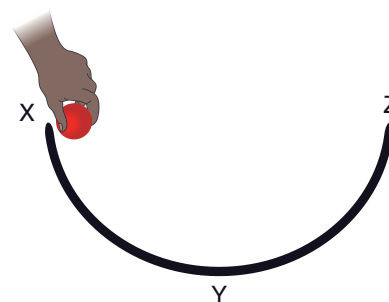

Figure 5.21

Contents	
Section	Learning competencies
6.1 Rotation about a fixed axis (page 119)	<ul style="list-style-type: none"> Describe the motion of a rigid body about a pivot point. Give the angular speed and angular velocity of a rotating body. Determine the velocity of a point in a rotating body.
6.2 Torque and angular acceleration (page 120)	<ul style="list-style-type: none"> Solve problems involving net torque and angular acceleration. Determine the velocity and acceleration of a point in a rotating body. Express torque as a cross product of \mathbf{r} and \mathbf{F}. Apply the cross product definition of torque to solve problems.
6.3 Rotational kinetic energy and rotational inertia (page 124)	<ul style="list-style-type: none"> Solve problems involving the moment of inertia. Apply the concepts of rotation dynamics and kinetic energy to solve problems. Identify factors affecting the moment of inertia of a body.
6.4 Rotational dynamics of a rigid body (page 129)	<ul style="list-style-type: none"> Derive equations of motion with constant angular acceleration. Use equations of motion with constant angular acceleration to solve related problems.
6.5 Parallel axis theorem (page 133)	<ul style="list-style-type: none"> State the parallel axis theorem. Use it to solve problems involving the moment of inertia.
6.6 Angular momentum and angular impulse (page 135)	<ul style="list-style-type: none"> Express angular momentum as a cross product of \mathbf{r} and \mathbf{p}. Derive an expression for angular momentum in terms of I and ω. Use the relationship between torque and angular momentum, according to Newton's second law. Apply the relationship between torque and angular momentum to solve problems involving rigid bodies.
6.7 Conservation of angular momentum (page 138)	<ul style="list-style-type: none"> State the law of conservation of angular momentum. Apply the law of conservation of angular momentum in understanding various natural phenomena, and solving problems.
6.8 Centre of mass of a rigid body (circular ring, disc, rod and sphere) (page 140)	<ul style="list-style-type: none"> Determine the location of centre of mass of a uniform rigid body.

In Unit 4 you learnt about uniform circular motion. In this unit you will learn how to apply the laws of motion for bodies moving in lines to bodies moving in circles. You will see that all of the equations of linear motion have equivalent equations for rotational motion.

6.1 Rotation about a fixed axis

By the end of this section you should be able to:

- Describe that motion of a rigid body about a pivot point.
- Give the angular speed and angular velocity of a rotating body.
- Determine the velocity of a point in a rotating body.

A rotating object spins about its **axis of rotation**. For example, the Earth's axis of rotation goes between the geographic north and south poles.

You learnt in Unit 4 that a body that is in uniform circular motion has a radial force acting on it. The body moves around an axis of rotation.

You should have noticed that when the object was spinning faster, the mass was pulled higher and so the tension in the string was higher. This means that the radial force keeping the object moving in the circle is higher when the object is moving faster.

We will now look at rigid bodies rotating around a fixed axis of rotation.

In everyday applications this rate of rotation may be described in terms such as the number of rotations per minute. In all theoretical work in physics, however, we specify it in radians per second. Remember that there are 2π radians in one complete turn.

If the flywheel turns through an angle θ in a time t , its angular velocity ω is defined by

$$\omega = \theta/t$$

In Unit 4, you learnt that the linear speed v and angular speed ω of a point on a rotating body are connected by the equation:

$$v = r\omega$$

where r is the distance of the point from the axis of rotation.

Remember that radians are dimensionless units and so are ignored when working out the dimensions of a quantity.

Worked example 6.1

A flywheel spins 250 times each minute. What is its angular velocity?

The angle turned through in $60\text{ s} = 250 \times 2\pi$ radians

Use the equation: $\omega = \theta/t$

Substituting in the values $\omega = 250 \times 2\pi/60 = 26\text{ rad/s}$

KEY WORDS

axis of rotation *the axis about which a body rotates*

Activity 6.1

- Set up a string, hollow tube and two masses as shown in Figure 6.1. The string should be able to move freely in the tube.
- Hold the tube vertically and swing the upper mass so that it is moving in a circle, with the tube as its axis of rotation.
- Increase the speed of rotation. What happens?
- Decrease the speed of rotation. What happens?

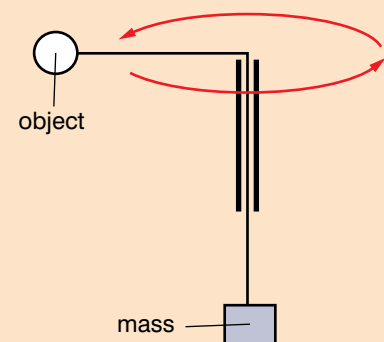

Figure 6.1 Apparatus for Activity 6.1

Worked example 6.2

A CD is rotating at 4800 revolutions per minute. What is the linear velocity of a point on the CD, 40 mm from the axis of rotation?

First find the angular velocity of the CD.

Angle turned through in 60 s = $4800 \times 2\pi$ radians

Use the equation: $\omega = \theta/t$

Substituting in the values
 $\omega = 4800 \times 2\pi/60 = 502.7$ rad/s

Velocity of point = $r\omega$

Substituting in the values
 $v = 0.04 \text{ m} \times 502.7 \text{ rad/s}$
 $= 20.1 \text{ m/s}$

KEY WORDS

torque *the turning effect of a force round a point; it is also a force*

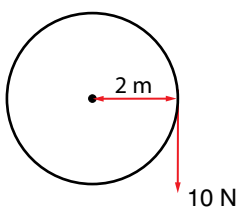

Torque about axis =
 $10 \text{ N} \times 2 \text{ m} = 20 \text{ N m}$

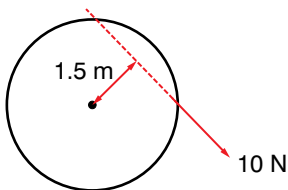

Torque about axis =
 $10 \text{ N} \times 1.5 \text{ m} = 15 \text{ N m}$

Figure 6.2 The value of a torque depends on the distance from the axis.

Summary

In this section you have learnt that:

- A rotating body rotates about its axis of rotation.
- Angular velocity ω and linear velocity v are connected by the equation $v = r\omega$.

Review questions

1. A car engine rotates at 3000 revolutions per minute. What is its angular velocity in rad/s?
2. The linear velocity of a point on a music CD is a constant 1.2 m/s when it is being played.

At the start of a CD, this point is 23 mm from the axis of rotation. At the end it is 58 mm from the axis of rotation. What is the angular velocity of the point at the start and the end?

3. A car is travelling at 16 m/s. The car wheel has a diameter of 0.7 m. What is the angular velocity of the wheel? Give your answer in rad/s.
4. A turbine is rotating at 3000 rev/min.
 - a) What is the angular velocity of the turbine? Give your answer in rad/s.
 - b) A turbine blade is 0.4 m long.

Calculate the linear velocity of a point on the end of a turbine blade and halfway down a blade.

6.2 Torque and angular acceleration

By the end of this section you should be able to:

- Solve problems involving net torque and angular acceleration.
- Determine the velocity and acceleration of a point in a rotating body.
- Express torque as a cross product of \mathbf{r} and \mathbf{F} .
- Apply the cross product definition of torque to solve problems.

Torque

In Unit 4, you learnt that a **torque** is a turning effect. It is the total moment acting on that body about the axis of rotation and is measured by multiplying the force by its perpendicular distance from the axis (Figure 6.2). The linear equivalent of a torque is a force.

Worked example 6.3

What is the torque shown in each of the diagrams in Figure 6.2?

Torque = force \times perpendicular distance

a) torque = $10 \text{ N} \times 2 \text{ m} = 20 \text{ N m}$

b) torque = $10 \text{ N} \times 1.5 \text{ m} = 15 \text{ N m}$

Look at Figure 6.4, which shows the directions of the force and displacement vectors. If the nut is being tightened up, then the nut will also move downwards as well as rotating.

In Unit 2, you learnt about the vector product of two vectors which is:

$$\mathbf{a} \times \mathbf{b} = |\mathbf{a}| |\mathbf{b}| \sin \theta \hat{\mathbf{n}}$$

where $|\mathbf{a}|$ and $|\mathbf{b}|$ are the magnitudes of \mathbf{a} and \mathbf{b} , respectively, θ is the smaller angle between \mathbf{a} and \mathbf{b} (θ is between 0° and 180°) and $\hat{\mathbf{n}}$ is a unit vector, which is perpendicular to the plane that \mathbf{a} and \mathbf{b} are in.

You also learnt that the direction of the unit vector is given by the right-hand rule, as shown in Figure 6.5. Hold the first two fingers and thumb of your right hand at right angles as shown in the diagram. Take the displacement to be in the direction of the index finger (\mathbf{a} on the diagram) and force to be in the direction of the middle finger (\mathbf{b} on the diagram). The direction of the unit vector is then given by the direction the thumb is pointing.

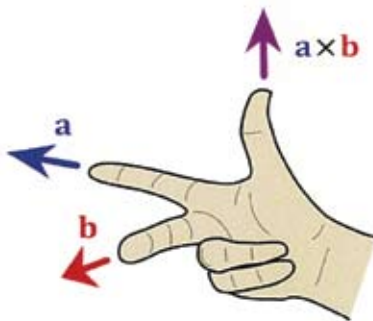

Remember that this only works when displacement and force are at right angles to each other.

Figure 6.5 The right-hand rule for finding the direction of the unit vector in the vector product of two vectors

If \mathbf{a} is force and \mathbf{b} is displacement, then you can see that applying the right hand-rule does give the direction of movement shown in Figure 6.4.

So we can say that torque is also the vector product of two vectors:

$$\boldsymbol{\tau} = \mathbf{r} \times \mathbf{F}$$

In Figure 6.2, the force and the displacement are at right angles to each other. What happens if they are not and the force is acting at an angle? By using the vector product we can find the torque.

From above, you can see that

$$\boldsymbol{\tau} = \mathbf{r} \times \mathbf{F} = |\mathbf{r}| |\mathbf{F}| \sin \theta$$

From Unit 2, you should also remember that we can also express the vector product as:

$$\boldsymbol{\tau} = (r_y F_z - r_z F_y) \hat{\mathbf{i}} + (r_z F_x - r_x F_z) \hat{\mathbf{j}} + (r_x F_y - r_y F_x) \hat{\mathbf{k}}$$



Figure 6.3 A mechanic uses torque to tighten up and undo nuts.

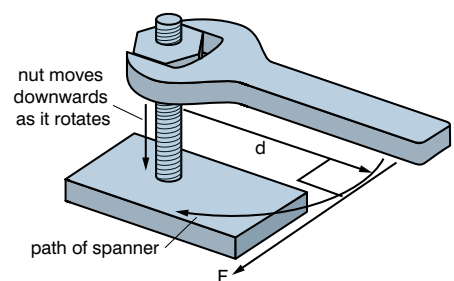

Figure 6.4 Force and displacement on a spanner

Activity 6.2

Try to undo a nut with a small spanner. Try with a much larger spanner. What do you notice? How can you explain this in relation to what you already know about torque?

Attach a newtonmeter to the end of the spanner. What force is required to make the spanner move?

Worked example 6.4

A force $\begin{bmatrix} 1 \\ 3 \end{bmatrix}$ acts at a displacement of $\begin{bmatrix} 4 \\ 2 \end{bmatrix}$. What is the torque produced by the force?

First draw a diagram to show the force and displacement (Figure 6.6).

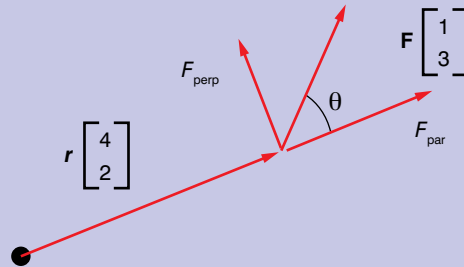

Figure 6.6

The component of the force \mathbf{F} that is perpendicular to the displacement \mathbf{r} is the part that we need to calculate the torque. This is given by:

$$F_{\text{perp}} = F \sin \theta$$

But we don't know what the angle θ is without calculating it. We could use the vector product:

$$\boldsymbol{\tau} = \mathbf{r} \times \mathbf{F} = |\mathbf{F}| |\mathbf{r}| \sin \theta \hat{\mathbf{n}}$$

but this also requires us to calculate $\sin \theta$. So we could use the other form of the vector product which is:

$$\boldsymbol{\tau} = \mathbf{r} \times \mathbf{F} = (r_x F_y - r_y F_x) \hat{\mathbf{k}}$$

$$\text{So } \boldsymbol{\tau} = (3 \times 4 - 1 \times 2) = 10 \text{ N m } \hat{\mathbf{k}}$$

As the torque is positive, this indicates that the torque is in the positive direction of the unit vector. Using the right-hand rule, we can see that this is out of the plane of the paper.

In linear terms the work done by a force is $\mathbf{F} \cdot \mathbf{s}$, the force \mathbf{F} multiplied by the displacement \mathbf{s} it moves in that direction. The rotational equivalent of linear displacement is angular displacement. Angular displacement is θ . The angular equivalent of force is torque, $\boldsymbol{\tau}$. So, when a torque turns a body, the work it does is the torque multiplied by the angle it turns through. Substitute $\boldsymbol{\tau}$ and θ into the equation for work done ($W = \mathbf{F} \cdot \mathbf{s}$):

$$W = \boldsymbol{\tau} \cdot \boldsymbol{\theta}$$

Torque has the same units as work done, newton metres (N m), but the units are not called joules, unlike for work done. The energy in work done is always a scalar (coming from the scalar product of force and displacement) but torque is a vector because it is the vector product of force and displacement. The displacement is the angle through which the torque acts.

Discussion activity

In small groups, discuss what causes an object to rotate more quickly or more slowly. How does this relate to rotational work done and rotational energy?

Report the conclusions for your discussion to the rest of the class.

Worked example 6.5

A mechanic tightens a nut and turns it through half a turn. A force of 270 N is used at a perpendicular distance of 50 cm. How much work is done by the mechanic? First draw a diagram (Figure 6.7). Half a turn is π radians.

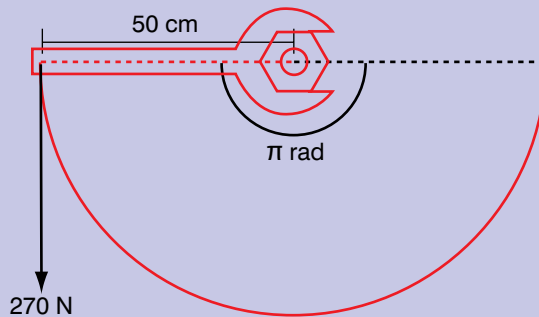
**Figure 6.7**

To find the torque, use the equation

$$\tau = \mathbf{r} \times \mathbf{F}$$

To find the work done, use the equation

$$W = \tau \cdot \theta$$

As displacement and force are perpendicular

$$\tau = rF \mathbf{k}$$

$$\text{So } W = (rF \mathbf{k}) \cdot \theta = rF\theta$$

Substituting the values into the equation:

$$W = 0.5 \text{ m} \times 270 \text{ N} \times \pi \text{ rad} = 424 \text{ J}$$

KEY WORDS

angular acceleration *the rate of change of angular velocity.*

Angular acceleration

Consider a flywheel that is rotating with an angular velocity ω . When the rate of rotation of the flywheel begins to increase, it is experiencing an **angular acceleration** α . If its angular velocity increases uniformly by $\Delta\omega$ over a time t , this is defined by:

$$\text{angular acceleration } \alpha = \Delta\omega/t$$

The units of angular acceleration are rad/s^2 .

Summary

In this section you have learnt that:

- A torque is a turning effect.
- Torque is the vector product of displacement and force.
- Angular acceleration is the change in angular velocity divided by the time taken for the change.

Worked example 6.6

A flywheel is rotating with an angular velocity of 4.2 rad/s. A force accelerates it uniformly to an angular velocity of 10.6 rad/s over 4 seconds.

What is the angular acceleration of the flywheel?

angular acceleration

$$\alpha = \Delta\omega/t$$

$$\begin{aligned} \Delta\omega &= 10.6 - 4.2 \text{ rad/s} \\ &= 6.4 \text{ rad/s} \end{aligned}$$

$$\begin{aligned} \alpha &= 6.4 \text{ rad/s} \div 4 \text{ s} \\ &= 1.6 \text{ rad/s}^2 \end{aligned}$$

Review questions

1. A CD in a CD drive in a computer accelerates from rest to 2000 revolutions per minute in 4 seconds. What is its angular acceleration?
2. A mechanic has two spanners, one 15 cm long and the second 20 cm long.
He applies a force of 30 N with the first spanner, and 20 N with the second. The forces are perpendicular to the spanner.
 - a) With which spanner does he produce the greatest torque?
 - b) How much work does he do with each spanner if he turns a nut one quarter of a turn?
3. A force $\begin{bmatrix} 2 \\ -5 \end{bmatrix}$ acts at a displacement of $\begin{bmatrix} 3 \\ 1 \end{bmatrix}$ from a point.
What is the torque exerted by the force?
4. A hard drive in a computer accelerates from rest to 5400 rev/min in 2 seconds.
What is the angular acceleration of the hard drive?
5. A tap in a hospital has a rod attached to the top of it which is 0.25 m long.
The rod is perpendicular to the axis of rotation of the tap.
It takes a force of 25 N quarter of a turn to turn the tap on.
 - a) What is the torque exerted on the tap?
 - b) How much work is done in turning on the tap?

KEY WORDS

rotational inertia *a measure of an object's resistance to changes in its speed of rotation over a certain time. Also known as moment of inertia*

6.3 Rotational kinetic energy and rotational inertia

By the end of this section you should be able to:

- Solve problems involving the moment of inertia.
- Apply the concepts of rotation dynamics and kinetic energy to solve problems.
- Identify factors affecting the moment of inertia of a body.

Rotational inertia

In linear motion, when a force F acts on a body of mass m , the body has an acceleration a , according to the equation $F = ma$.

When a body is rotating at a constant angular velocity and is acted on by a torque τ , this will produce an acceleration, α , so

$$\tau = I\alpha$$

where I is known as the **rotational inertia**, or moment of inertia. It is the rotational equivalent of mass.

The moment of inertia of a body is defined as:

$$I = \sum m_i r_i^2$$

where m_i is the mass of a point of the body and r_i is the distance of the point from the axis of rotation (see Figure 6.8).

The moment of inertia of a body is a measure of the manner in which the mass of that body is distributed in relation to the axis about which that body is rotating. It depends on the:

- mass of the body
- size of the body
- which axis is being considered.

If we put the dimensions in the equation $\tau = I\alpha$, we can work out its dimensions.

$$I = \tau/\alpha = \text{N m}/(\text{rad}/\text{s}^2)$$

When considering dimensions we ignore radians, and as the dimension of newtons are also $\text{kg m}/\text{s}^2$, the dimensions of I are:

$$I = \text{kg m}/\text{s}^2 \times \text{m} \times \text{s}^2 = \text{kg m}^2.$$

The moments of inertia of some bodies are:

A disc of mass M and radius R (as with the first flywheel):

$$I = \frac{1}{2}MR^2$$

A sphere of mass M and radius R : $I = \frac{2}{5}MR^2$

A thin rod or bar: $I = \frac{1}{12}ML^2$ where L is the length of the bar.

Note: these moments of inertia only apply when the axis of rotation goes through the centre of mass of the body.

Thin rod or bar being rotated about its end: $I = \frac{1}{3}ML^2$, where L is the length of the bar.

The moment of inertia of a body is not constant for that body because it depends on the axis chosen for it to rotate around. As indicated above, it may be defined for a given body about a given axis as the sum of mr^2 for every particle in that body (where m is the mass of the particle and r is its distance from the axis).

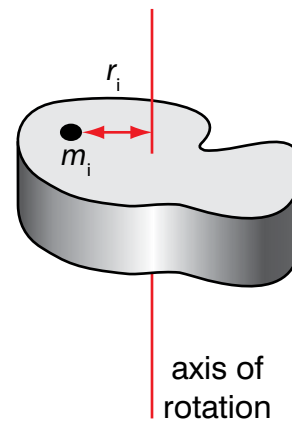

Figure 6.8

Worked example 6.7

A rotating drum in a fairground ride is accelerated from rest by a torque of 5000 N m. The moment of inertia of the drum is 16 000 kg m².

What is the angular acceleration of the drum?

Angular acceleration,
 $\alpha = \tau/I$

Substituting in the values
 $\alpha = 5000 \text{ N m}/16\,000 \text{ kg m}^2$
 $= 0.3125 \text{ rad}/\text{s}^2$

Table 6.1 Moments of inertia for different bodies

Body							
disc	solid sphere	hollow sphere	thin rod or bar	thin rod or bar	thin cylindrical shell	solid cylinder	rectangular slab
Moment of inertia when axis of rotation goes through centre of body							
$\frac{1}{2}MR^2$	$\frac{2}{5}MR^2$	$\frac{2}{3}MR^2$	$\frac{1}{12}ML^2$	$\frac{1}{3}ML^2$ (when rotated about the end of the thin rod or bar)	MR^2	$\frac{1}{2}MR^2$	$\frac{1}{12}M(h^2 + w^2)$

Activity 6.3

You are going to find the moment of inertia of a flywheel and then use it to find the moment of inertia of other objects.

Set up your apparatus as in Figure 6.9.

It consists of a spindle of radius r with a platform mounted on top of it. A string is attached to the spindle, wrapped around it and taken over a pulley. A weight is attached to the end of the string. When the weight is released, it falls downwards and pulls the string off the spindle, which applies a torque to the spindle and platform.

When the weight is released, it accelerates downwards with acceleration a . We can use Newton's second law of motion to find the tension T in the string:

$$F = ma$$

$$ma = mg - T$$

$$\text{so } T = mg - ma$$

The tension in the string produces a torque on the spindle, which leads to an angular acceleration.

The torque is given by:

$$\tau = I\alpha \text{ and } \tau = Tr$$

$$\text{So } I\alpha = (mg - ma)r$$

$$I = m(g - a)r/\alpha$$

You need to measure the acceleration of the weight falling downwards, and the angular acceleration of the spindle.

When you have calculated the moment of inertia for the platform, place an object on the platform and find its moment of inertia. You will need to make sure that the centre of mass of the object is on the axis of rotation of the platform.

Plan your experiment, carry it out and then write a report using the writing frame in Section 1.4, page 19–20.

What potential errors are there in your data? What is the uncertainty in your data?

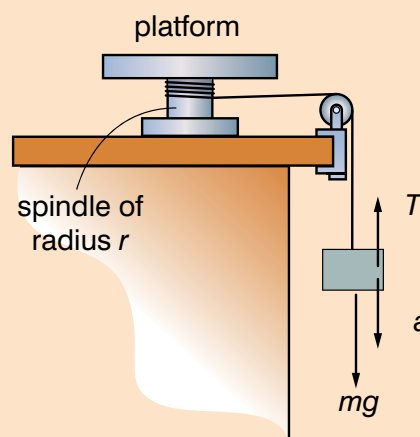

Figure 6.9 Apparatus for Activity 6.3

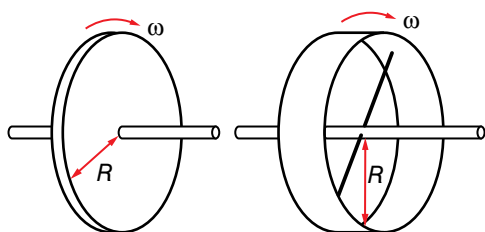

Figure 6.10 Two wheels of the same mass but different construction

Rotational kinetic energy

A spinning flywheel possesses kinetic energy, but how much? The amount of that energy depends partly on how rapidly it is going round, that is, how large its angular velocity is. The expression $E_k = \frac{1}{2}mv^2$ still applies of course, but the difficulty is that different parts of the flywheel are moving at different speeds – the regions further from the axis are moving faster.

With linear motion the kinetic energy is determined solely by the mass of the body and its speed. With the flywheel the mass and the angular velocity are important but there is now a third factor – how that mass is distributed in relation to the axis. Consider two wheels each of mass M but one is made in the form of a uniform disc whereas the other consists of a ring of the same radius R fixed to the axle by very light spokes (Figure 6.10). Both are spinning with the same angular velocity ω .

We can easily calculate the kinetic energy stored in the second flywheel because all its mass is at the rim. You know from your

earlier studies that for a point mass going steadily in a circle of radius r at a linear speed v , that the speed is related to angular velocity by:

$$\omega = v/r \text{ so } v = r\omega$$

This flywheel has an angular velocity ω , and since the whole of its mass is moving in a circle of radius R it is all travelling at a linear speed $v = R\omega$. The kinetic energy, $\frac{1}{2}mv^2$ of the flywheel will be $\frac{1}{2}MR^2\omega^2$.

What can we say about the first flywheel? Its total kinetic energy will be less, because most of its mass is moving at a slower speed than v . How can we go further than that?

A way forward is to think of the wheel as consisting of a large number of separate particles. There is no need to relate them to the individual atoms of the metal – we are just imagining it to be made up of a huge number of very small bits.

One of these bits, of mass m and distance r out from the axis, will have its share of the kinetic energy given by $\frac{1}{2}mv^2$, which can be expressed as $\frac{1}{2}mr^2\omega^2$, since $v = r\omega$.

The total kinetic energy of the whole flywheel is just the sum of that of every particle in it. Those particles have different speeds v , but every one has the same angular velocity ω .

Adding all those kinetic energies, and denoting each particle with a subscript 1, 2, 3 etc, we get:

$$\text{total kinetic energy} = \frac{1}{2}m_1r_1^2\omega^2 + \frac{1}{2}m_2r_2^2\omega^2 + \frac{1}{2}m_3r_3^2\omega^2 + \dots$$

We can rewrite this as:

$$\text{total KE} = \frac{1}{2}(m_1r_1^2 + m_2r_2^2 + m_3r_3^2 + \dots)\omega^2$$

We can simplify it if we replace all those separate values of r^2 by the average value of r^2 for all the particles in that body. It then becomes the total mass M of the body (which can be measured with an ordinary balance) multiplied by the average value of r^2 for all the particles (which can be calculated by a geometrical exercise for various shapes of body).

The expression in the brackets is the equivalent of mass for the rotational equivalent of $\frac{1}{2}mv^2$ and is the moment of inertia.

So we can express the **rotational kinetic energy** of a body as:

$$E_k = \frac{1}{2}I\omega^2$$

Worked example 6.8

The rotating drum in the previous worked example has an angular velocity of π rad/s.

How much rotational kinetic energy does it have?

$$\text{Rotational kinetic energy} = \frac{1}{2}I\omega^2$$

$$\text{Substituting in the values} = \frac{1}{2} \times 16\,000 \times \pi^2 = 78.96 \text{ kJ}$$

KEY WORDS

rotational kinetic energy
the amount of kinetic energy a rigid body has from its rotational movement

Activity 6.4

Set up an inclined plane. You will be given two identical cans – both of them are filled with a liquid, but one of them has been frozen. Roll the cans down the plane together.

What do you notice about the motion of the cans?

Activity 6.5

Set up an inclined plane. Roll different objects down the plane. What does this tell you about the mass distribution in the body?

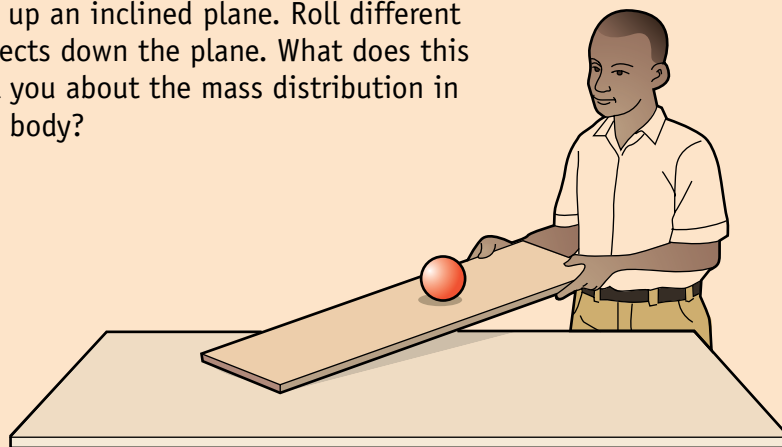

Figure 6.11 Rolling an object down an inclined plane

Summary

In this section you have learnt that:

- The moment of inertia is a measure of an object's resistance to changes in its speed of rotation.
- The moment of inertia depends on the axis of rotation for many objects.
- The rotational equivalent of Newton's second law ($F = ma$) is $\tau = I\alpha$, where τ is the torque, I is the moment of inertia and α is the angular acceleration.
- The rotational kinetic energy of a body is given by the equation $E_k = \frac{1}{2}I\omega^2$, where ω is the angular velocity.

Review questions

Figure 6.12

1. In Figure 6.12 a long cylinder is spun first about its longitudinal axis (a) and then about a perpendicular axis (b).
If both rotations have the same angular velocity, which rotation will have the greater kinetic energy? Explain your answer fully.
2. The Earth may be considered as a sphere of mass 6.0×10^{24} kg and radius 6.4×10^6 m.
 - a) Given that it spins on its axis once a day, work out its angular velocity.
 - b) Work out its kinetic energy of rotation. Use the information in the section above.
3. A starter cord for a generator is 1 m long. It is wound onto a drum with a diameter of 10 cm.
A person starts the generator by pulling with a force of 100 N.
 - a) What torque does he apply to the engine?
 - b) How much work does he do?

6.4 Rotational dynamics of a rigid body

By the end of this section you should be able to:

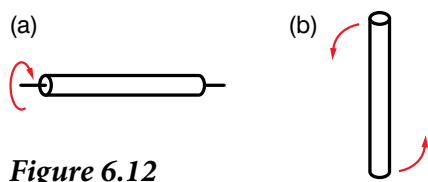
- Derive equations of motion with constant angular acceleration.
- Use equations of motion with constant angular acceleration to solve related problems.

You should already be familiar with the four equations of linear motion, which you used in earlier units. Each of these equations has an equivalent equation for rotational motion. The quantities in the equations are replaced with their rotational equivalents.

The linear quantities and their rotational equivalents are given in Table 6.2.

Table 6.2 Linear and rotational motion

Linear motion		Rotational motion	
Quantity	Unit	Quantity	Unit
displacement, s	m	angular displacement, θ	rad
velocity, v	m/s	angular velocity, ω	rad/s
acceleration, a	m/s ²	angular acceleration, α	rad/s ²
mass, m	kg	rotational inertia, I	kg m ²
force, F	N	torque, τ	N m

We can use these equations to solve problems in exactly the same way as we did for linear motion. For example, the equation $s = ut + \frac{1}{2}at^2$ may be applied in cases of uniform rotational acceleration as well. All you need to do is replace distance s by the angle θ and u and v by the values of ω at the start and finish and a by the angular acceleration α .

So the equations of motion are:

Linear motion	Rotational motion
$v = u + at$	$\omega_2 = \omega_1 + \alpha t$
$s = ut + \frac{1}{2}at^2$	$\theta = \omega_1 t + \frac{1}{2}\alpha t^2$
$v^2 = u^2 + 2as$	$\omega_2^2 = \omega_1^2 + 2\alpha\theta$
$s = \frac{(u + v)t}{2}$	$\theta = \frac{(\omega_1 + \omega_2)t}{2}$



Figure 6.14 A cat will try to turn its body during a fall so that it is facing the ground.

We use a frame of reference when we apply these equations to rotational motion, in the same way that we have a frame of reference with linear motion.

In rotational motion, positive angular displacement, velocity and acceleration are in the anticlockwise direction, and negative angular displacement, velocity and acceleration are in the clockwise direction (Figure 6.13).

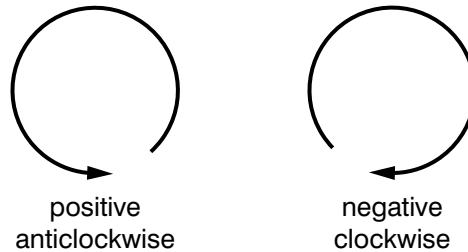

Figure 6.13 Frame of reference for rotational motion

There is a myth that when cats fall they always end up on their feet – but they don’t always. Figure 6.14 shows what cats try to do – they try to turn in mid-air.

If a cat falls back first, it will try to stick out its rear legs and then twist the front half of its body towards the ground. The back half rotates in the opposite direction, but not as far. The cat then extends its front legs, tucks its back legs in and rotates them towards the ground.

Activity 6.6

Look at the photo of the falling cat in Figure 6.14. How can you use rotational inertia to explain what happens?

Activity 6.7

Construct a yo-yo using a discarded metal spool. Attach a string to the inner spindle and wrap it several times around the spindle.

Can you work out what makes the best yo-yo? Can you explain this in terms of what you know about rotational motion?

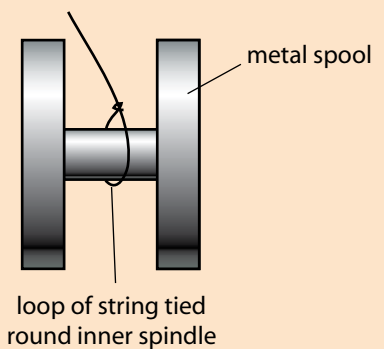

Figure 6.15

Worked example 6.9

You are on a big wheel at a fairground which makes 1 revolution every 8 seconds. The operator of the wheel decided to stop the wheel by applying the brakes. The brakes produce an acceleration of -0.1 rad/s^2 .

Your seat is 4 m from the axis of rotation.

- What is the angular velocity of the wheel?
- What is your velocity before the brakes are applied?
- How long does it take the big wheel to stop?
- How many revolutions does the wheel make before it comes to a stop?
- How far do you travel while the wheel is slowing down?

First draw a diagram to help you (Figure 6.16).

- The wheel does 1 revolution in 8 seconds.

The angle turned through in 1 second is $1/8 \times 2\pi$ radians = $\pi/4$ radians

Angular velocity is $\pi/4$ or 0.785 rad/s

- Velocity = $r\omega = 4 \times 0.785 = 3.14 \text{ m/s}$

- Use the equation that involves initial and final angular velocity, angular acceleration and time: $\omega_2 = \omega_1 + \alpha t$

$$t = (\omega_2 - \omega_1)/\alpha = (0 - 0.785)/-0.1 = 7.85 \text{ seconds}$$

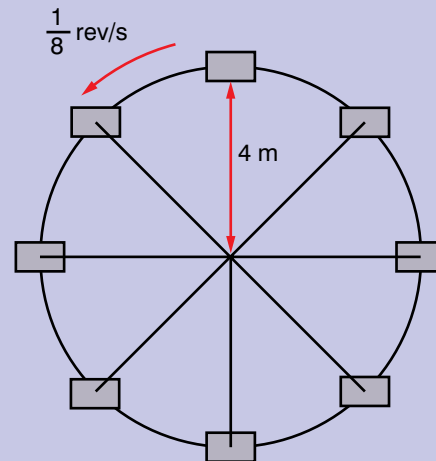

Figure 6.16

- Use the equation that involves initial and final angular velocity, angular acceleration and distance: $\omega_2^2 = \omega_1^2 + 2\alpha\theta$

$$\theta = (\omega_2^2 - \omega_1^2)/2\alpha$$

$$= (0 - 0.785^2)/2 \times -0.1 = 3.081 \text{ rad}$$

1 revolution is 2π radians, so this is $3.081/2\pi$ of a revolution = 0.49 of a revolution

- Distance = $r\theta = 4 \times 3.081 = 12.3 \text{ m}$

Worked example 6.10

A string is wrapped round a cylinder of mass 500 g and radius 10 cm, which is sitting on a flat surface. The string comes off the top of the cylinder horizontally. The string is pulled with a force 10 N. The coefficient of static friction between the cylinder and surface is 0.4.

What is the acceleration of the cylinder if the cylinder rolls without slipping?

First draw a diagram as shown in Figure 6.17. Remember that there is a static friction force acting on the cylinder.

$I = R$ (pulling force – force due to static friction)

$$= R(F - \mu_s F_N)$$

But torque = moment of inertia \times angular acceleration $I = I\alpha$

$$= \frac{1}{2}MR^2\alpha$$

$$\frac{1}{2}MR^2\alpha = R(F - \mu_s F_N)$$

$$\alpha = \frac{2(F - \mu_s F_N)}{MR}$$

$$= \frac{2(5 - 0.4 \times 0.5 \times 9.8)}{0.5 \times 0.1}$$

$$= \frac{2 \times 3.04}{0.05}$$

$$= 121.6 \text{ rad/s}^2$$

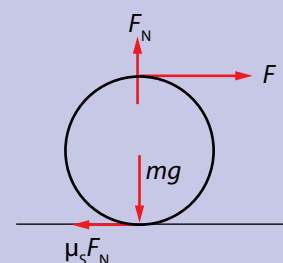

Figure 6.17

Activity 6.8

Consider a ring, sphere and solid cylinder all with the same mass. They are all held at the top of an inclined plane which is at 20° to the horizontal. The top of the inclined plane is 1 m high. The shapes are released simultaneously and allowed to roll down the inclined plane. Assume the objects roll without slipping and that they are all made from the same material. Assume the coefficient of static friction between the objects and plane to be 0.3.

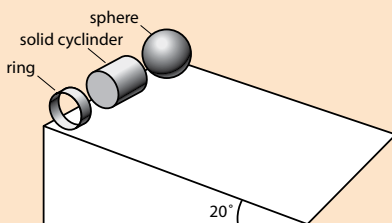

Figure 6.18

By considering the equations of motion, work out what order they would get to the bottom of the slope. How long will it take each shape to reach the bottom the slope?

Worked example 6.11

A mechanic applies a torque of 100 N m over a half turn and takes 2 seconds. What is the power?

Angular velocity $\omega = \pi/2$ rad/s

Power = $\tau\omega$

Substituting in the values

$$p = 100 \text{ N m} \times \pi/2 \text{ rad/s} \\ = 50 \pi \text{ W or } 157 \text{ W.}$$

In Section 6.2, you learnt that the work done by a torque is:

$$\text{Work done} = \text{torque} \times \text{angle moved through} = \tau\theta$$

We can also calculate the power, which is work done divided by time.

$$\text{Power} = \tau\theta/t$$

Now θ/t is also angular velocity ω , so power is

$$P = \tau\omega$$

Summary

In this section you have learnt:

- The linear variables of motion all have rotational equivalents.
- The equations of rotational motion are equivalent to the equations of linear motion.
- How to apply the rotational equations of motion.
- To calculate the power of a torque.

Review questions

1. A flywheel begins rotating from rest, with an angular acceleration of 0.40 rad/s^2 .
 - a) What will its angular velocity be 3 seconds later?
 - b) What angle will it have turned through in that time?
2. A flywheel is rotating with an angular velocity of 1.4 rad/s and is acted on by an acceleration of 0.6 rad/s^2 .
 - a) What angular velocity will it have attained after three complete turns?
 - b) How long will it take to do those three turns?
3. A flywheel of mass 3.0 kg consists of a flat uniform disc of radius 0.40 m. It pivots about a central axis perpendicular to its plane.
 - a) Calculate its moment of inertia, using information from this unit.
 - b) A torque of 6.8 N m acts on it. How will it respond?
4. A vehicle is being planned that is driven by a flywheel engine. It has to run for at least 30 minutes and develop a steady power of 500 W.
 - a) How much energy will the flywheel need to supply?
 - b) The largest flywheel that can be fitted has a moment of inertia of 20 kg m^2 . Work out how fast (in revolutions per minute) it will need to be turning at the beginning.
 - c) Suggest a way in which such a vehicle might be refuelled.

5. A big wheel has a diameter of 5 m and a mass of 1500 kg when fully laden with people.
- Work out the moment of inertia of the big wheel. (Hint: which shape from the ones given on p114 would be most suitable?)
 - When the wheel is rotating at full speed, a person has a linear velocity of 3 m/s.
What is the angular velocity of this person?
 - What is the rotational kinetic energy at this speed?
 - A motor takes 10 seconds to accelerate the wheel from rest to a linear velocity on the circumference of 3 m/s. What is the power of the motor?

6.5 Parallel axis theorem

By the end of this section you should be able to:

- State the parallel axis theorem.
- Use it to solve problems involving the moment of inertia.

In Section 6.4 you learnt about the moment of inertia of a body and how you can find the moment of inertia when the axis of rotation for the moment of inertia went through the body's centre of mass.

What happens when you want to rotate the body about an axis that does not pass through the body's centre of mass? If the axis of rotation is parallel to the axis that is used to calculate the moment of inertia about the centre of mass, there is a simple relationship between the two moments of inertia:

$$I_p = I_{cm} + Md^2$$

where I_p is the moment of inertia about the axis parallel to the one used to calculate the moment of inertia about the centre of mass, I_{cm} is the moment of inertia about the centre of mass, M is the mass of the body and d is the displacement of I_p from I_{cm} .

This is known as the parallel axis theorem, which states that if you know the moment of inertia about the centre of mass, you can find it about any pivot point using the parallel axis theorem provided that the axes of rotation are parallel.

For example, the moment of inertia around the centre of mass for a rod is $\frac{1}{12}ML^2$ where L is the length of the rod. If we now rotate it about one of its ends, as shown in Figure 6.20, using the parallel axis theorem:

$$\begin{aligned} I_p &= I_{cm} + Md^2 \\ &= \frac{1}{12}ML^2 + M(L/2)^2 = \frac{1}{12}ML^2 + \frac{1}{4}ML^2 = \frac{4}{12}ML^2 = \frac{1}{3}ML^2 \end{aligned}$$

This is the result that is shown in Section 6.4.

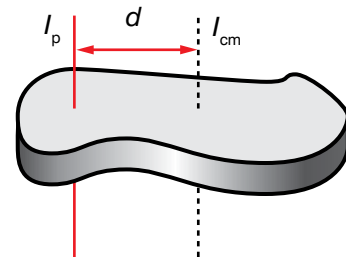

Figure 6.19 Parallel axis theorem

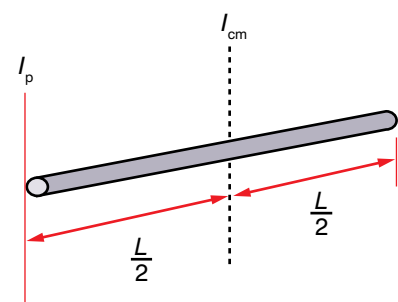

Figure 6.20 Applying the parallel axis theorem to a rod

Activity 6.9

You are going to investigate the parallel axis theorem. Carry out Activity 6.6 in Section 6.4 again, but this time with one of the objects off to one side of the platform. Measure the distance you move the object from the centre of the axis of rotation of the platform.

Can your results show that the parallel axis theorem is true?

Note that the displacement of I_p from I_{cm} can also be a vector. If it is, you need to find the magnitude of the vector to apply it in the parallel axis theorem.

Worked example 6.12

A body of mass 2 kg has a moment of inertia about its centre of mass of 20 kg m^2 . It is then rotated about an axis which has a displacement of $\begin{bmatrix} 2 \\ 3 \end{bmatrix} \text{ m}$.

Find the moment of inertia of the body about the axis $\begin{bmatrix} 2 \\ 3 \end{bmatrix} \text{ m}$.

Use Pythagoras's theorem to find the magnitude of the displacement:

$$d = \sqrt{(2^2 + 3^2)} = \sqrt{(4 + 9)} = \sqrt{13}$$

Using the parallel axis theorem:

$$I_p = I_{cm} + Md^2$$

$$\begin{aligned} \text{Substituting in the values } I_p &= 20 \text{ kg m}^2 + 2 \text{ kg} \times (\sqrt{13} \text{ m})^2 \\ &= 20 \text{ kg m}^2 + 7.2 \text{ kg m}^2 \\ &= 27.2 \text{ kg m}^2 \end{aligned}$$

You should also be able to see from the worked example that the term Md^2 has the same dimensions as I_{cm} .

Summary

In this section you have learnt that:

- The parallel axis theorem can be used to find the moment of inertia about any pivot point as long as the axis is parallel to the one used to find the moment of inertia.

Review questions

1. The moment of inertia of an object of mass 4 kg is 15 kg m^2 . Use the parallel axis theorem to find the moment of inertia about an axis that has a displacement $\begin{bmatrix} 5 \\ 12 \end{bmatrix} \text{ m}$.
2. The moment of inertia of a uniform sphere is $\frac{2}{5}MR^2$. Use the parallel axis theorem to show that the moment of inertia about any point on its surface is $\frac{7}{5}MR^2$.

6.6 Angular momentum and angular impulse

By the end of this section you should be able to:

- Express angular momentum as a cross product of \mathbf{r} and \mathbf{p}
- Derive an expression for angular momentum in terms of I and ω .
- Use the relationship between torque and angular momentum, according to Newton's second law.
- Apply the relationship between torque and angular momentum to solve problems involving rigid bodies.

Angular momentum

The linear momentum of a particle is the product of mass and velocity:

$$\mathbf{p} = m\mathbf{v}$$

The equivalent to linear momentum in rotational dynamics is angular momentum, \mathbf{L} . It is defined as the vector product of the displacement from the axis of rotation \mathbf{r} and linear momentum \mathbf{p} :

$$\mathbf{L} = \mathbf{r} \times \mathbf{p}$$

We can substitute the equation for linear momentum into this equation, so angular momentum becomes:

$$\mathbf{L} = m\mathbf{r} \times \mathbf{v}$$

If \mathbf{v} is not perpendicular to \mathbf{r} , then (in terms of magnitudes) $L = rmv \sin \theta$ where θ is the angle between \mathbf{r} and \mathbf{v} .

Look at the ball rotating about the axis shown in Figure 6.22. The diagram shows the directions of each of the vectors. The direction of **angular momentum** is shown by the vertical green arrow, which is perpendicular to both displacement and momentum or angular velocity.

You can also show the direction of angular momentum using the right-hand rule, as described on page 121.

Look at the equation for angular momentum more closely (in terms of magnitudes):

$$L = mrv$$

We know that the rotational equivalent of v is ωr . Substitute this into the equation:

$$L = m\mathbf{r} \times \omega\mathbf{r} = mr^2\omega$$

Now for a point rotating about an axis, mr^2 is the moment of inertia of the point, I . So we can write the angular momentum of a rotating body as:

$$L = I\omega$$

As I has units kg m^2 and ω has units rad/s , angular momentum has units $\text{kg m}^2/\text{s}$.

KEY WORDS

angular momentum

momentum of a body due to its angular velocity



Figure 6.21 A gyroscope in action

DID YOU KNOW?

A gyroscope is a device that has a disc that is able to spin freely in any dimension. The faster it spins, the more stable it is. They can be used in navigation – for example, in the Hubble Space Telescope.

When a gyroscope is spinning fast, it will stand on a point.

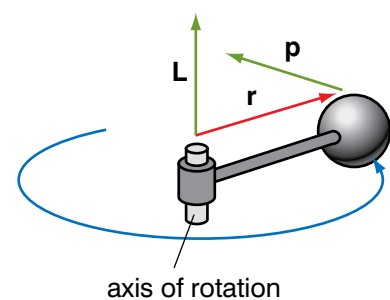

Figure 6.22 Angular momentum of a ball rotating about a vertical axis



Figure 6.23 The Hubble Space Telescope makes use of gyroscopes to help with moving the telescope to point at the position in the sky correctly

Activity 6.10

Stand or sit on a rotating platform. Get someone to hold on to the platform to stop it spinning. Hold a bicycle wheel by its axle over your head so that its axis of rotation is the same as the axis of rotation of the rotating platform. With your free hand spin the bicycle wheel so that it is spinning as fast as possible. The student hanging on to the platform should now let go. Grab the wheel to stop it. What happens?

Repeat, but this time with no one stopping the turntable from moving when you spin the wheel. What happens?

Repeat again, but this time leave the wheel spinning. Change the axis of rotation of the wheel from vertical to horizontal. What happens?

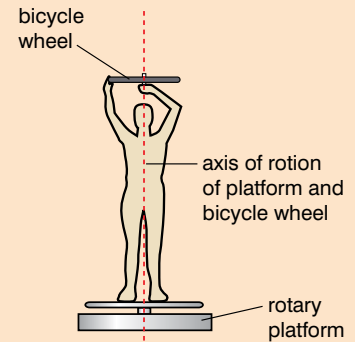

Figure 6.24

Worked example 6.13

A flywheel is rotating at 1000 revolutions per minute and has a moment of inertia of 50 kg m^2 . What is its angular momentum?

Angular momentum = moment of inertia \times angular velocity

$$L = I\omega$$

Angular velocity

$$= \frac{1000 \times 2\pi}{60} = \frac{100\pi}{3} \text{ rad/s}$$

$$L = 50 \text{ kg m}^2 \times \frac{100\pi}{3} \text{ rad/s} \\ = 5233.3 \text{ kg m}^2/\text{s}$$

KEY WORDS

angular impulse *the change in angular momentum of a rotating body caused by a torque acting over a certain time*

Angular impulse

In Section 4.3 you learnt that the effect of an unbalanced force on a body is to cause its momentum to change. By Newton's second law of motion the momentum changes at a rate that is proportional to the magnitude of that force and this leads to $F = ma$.

An impulse in linear motion is when there is a change in the linear momentum of a body. The impulse is the change in momentum, or the mass multiplied by the change in velocity. The impulse is also related to the force used to change the velocity and is the force multiplied by the time it was applied for.

Similarly, the effect of an unbalanced torque on a body that can rotate is to cause its angular momentum to change, at a rate which is proportional to the magnitude of the torque. This leads to $\tau = I\alpha$ (the moment of inertia multiplied by the angular acceleration).

Impulses also apply to rotational motion, where they are called angular impulses. Exactly the same principles apply. So a change in angular momentum is called an **angular impulse**. As for a linear impulse, we can write it in two ways:

change in angular momentum, $\Delta L = \text{torque } \tau \times \text{time torque acts for, } \Delta t$

or change in angular momentum, $\Delta L = \text{moment of inertia, } I \times \text{change in angular velocity } \Delta\omega$

A small torque applied for a long time has the same effect as a large force applied for a small time.

Worked example 6.14

The sign shown in Figure 6.25 rotates about a vertical axis of rotation. It rotates when wind blows on it and has a moment of inertia of 0.056 kg m^2 .

On a still day, the sign is at rest. A truck drives past which produces a gust of wind that gives the sign an angular impulse of $1.5 \text{ kg m}^2 \text{ rad/s}$ to the sign. The sign accelerates over a time of 2.4 s .

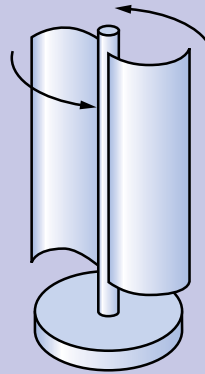

Figure 6.25
Rotating sign

- What is the angular momentum acquired by the sign as a result of the angular impulse?
- What is the angular velocity of the sign immediately after the impulse?
- What was the torque that acted on the sign?

a) The angular momentum of the sign is $1.5 \text{ kg m}^2 \text{ rad/s}$ because there has been an angular impulse of $1.5 \text{ kg m}^2 \text{ rad/s}$ and the angular momentum of the sign was zero at the start.

b) $L = I\omega$ so $\omega = L/I$

Sustituting in the values

$$\omega = 1.5 \text{ kg m}^2 \text{ rad/s} \div 0.056 \text{ kg m}^2 = 26.8 \text{ rad/s}$$

c) $\Delta L = \tau \Delta t$, so $\tau = \Delta L/\Delta t$

Sustituting in the values

$$\tau = 1.5 \text{ kg m}^2 \text{ rad/s} \div 2.4 \text{ s} = 0.63 \text{ N m}$$

Project work

Research one of the following questions, searching literature, the internet or any other reliable source.

- Why is it easier to balance on a bicycle when it is moving? Why is it so difficult to balance on a bicycle when it is still?
- Why does a rolling coin keep rolling and not topple until it has nearly stopped rolling?

You should be able to use what you have learnt in this unit to help you. Write a report explaining your findings, or do a presentation to the rest of your class.

Activity 6.11

You are going to investigate the angular momentum of a spinning egg.

Spin a raw egg rapidly on its side. Stop it spinning and then quickly release it. What happens?

Repeat with a hard-boiled egg. What happens? Can you explain why?

Summary

In this section you have learnt that:

- The angular momentum, L , of a rotating body is $I\omega$.
- Angular impulse is the change in angular momentum, which is torque multiplied by the time torque acts for.
- Angular impulse is also equal to the moment of inertia multiplied by the change in angular velocity.

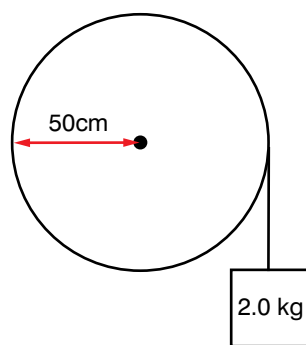

Figure 6.26

Activity 6.12

Look at the photo of the falling cat in Figure 6.14. Can you explain what is happening in terms of the conservation of angular momentum?

Review questions

- Figure 6.26 shows a flywheel of mass 12 kg and radius 50 cm with a rope wrapped around it. On the end of the rope is a 2.0 kg load. Initially it is at rest.
 - Calculate the torque on the flywheel. Assume g to be 9.8 m/s^2 .
 - Work out what its angular momentum will be after 2.5 s.

Angular momentum is a vector and so will have a direction. You can use the right-hand rule to show its direction.

6.7 Conservation of angular momentum

By the end of this section you should be able to:

- State the law of conservation of angular momentum.
- Apply the law of conservation of angular momentum in understanding various natural phenomena, and solving problems.

Just as linear momentum is conserved in the absence of a force, so the conservation of angular momentum says:

if no resultant torque is acting, the angular momentum of a body cannot change.

We can also express this as an equation:

$$L_f = L_i$$

where L_f is the final angular momentum and L_i is the initial angular momentum. We can also express this as:

$$I_f \omega_f = I_i \omega_i$$

Worked example 6.15

A potter in a village throws large clay pots on a wheel. The wheel rotates freely on a vertical axis and is driven by the potter. The potter applies a tangential force repeatedly to its rim until the wheel reaches a certain angular velocity. He then throws a lump of clay onto the centre of the wheel.

The angular velocity of the wheel is 5.0 rad/s just before he throws the lump of clay onto it. The moments of inertia of the wheel and the clay about the axis of rotation are 1.7 kg m^2 and 0.3 kg m^2 , respectively. When the clay is added, the angular velocity of the wheel

changes suddenly. The net angular impulse is zero. Calculate the angular velocity of the wheel immediately after the clay has been added.

Angular momentum is conserved because there is no angular impulse.

Angular momentum just before clay is thrown on wheel = $I\omega = 1.7 \text{ kg m}^2 \times 5 \text{ rad/s} = 8.5 \text{ kg m}^2/\text{s}$

Moment of inertia of wheel with the clay = $1.7 \text{ kg m}^2 + 0.3 \text{ kg m}^2 = 2.0 \text{ kg m}^2$

Angular velocity after clay is thrown on wheel = $8.5 \text{ kg m}^2/\text{s} \div 2.0 \text{ kg m}^2 = 4.25 \text{ rad/s}$

Activity 6.13

Sit on a turntable or a chair that will swivel freely. Ask someone else to spin you and the turntable or chair as fast as they can. Your arms should be held sticking out horizontally from your body (see Figure 6.27a). Bring your arms close into your chest (see Figure 6.27b). What happens? Can you explain it in terms of the conservation of angular momentum? What about rotational kinetic energy?

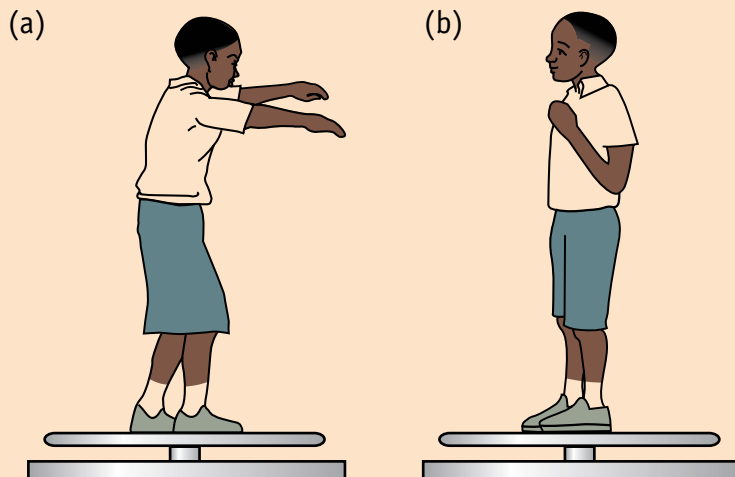

Figure 6.27 Investigating the conservation of angular momentum using a turntable

DID YOU KNOW?

Skateboarders turn their board in mid-air by making use of the law of conservation of angular momentum. They twist their arms and legs in opposite directions – angular momentum is conserved!



Figure 6.28 Skateboarder using the law of conservation of angular momentum

Summary

In this section you have learnt that:

- The law of conservation of angular momentum states that if no resultant torque is acting, the angular momentum of a body cannot change.

Discussion activity

In what other movements in sport can you apply the law of conservation of angular momentum to explain what happens?

Review question

1. A skater is spinning with an angular velocity 5 rad/s . The skater has her arms close to her body. Her moment of inertia is 1.2 kg m^2 . She puts her arms out and her angular velocity decreases to 3 rad/s . What is her moment of inertia now?

Activity 6.14

You are going to investigate how the centre of mass of an object can help it to balance.

Take two objects such as forks or screwdrivers and push them into a piece of soft wood, as shown in Figure 6.29. Now push in an object such as a nail, screw or large pin. Can you balance the object on the edge of a glass as shown in Figure 6.29?

Can you explain why the object balances?



Figure 6.29 Why does the object balance on the edge of the glass?

6.8 Centre of mass of a rigid body (circular ring, disc, rod and sphere)

By the end of this section you should be able to:

- Determine the location of centre of mass of a uniform rigid body.

In Unit 4, you learnt about the centre of mass and how it can affect the stability of objects. You learnt that the centre of mass of two objects connected by a rod is at the point where they would balance if the rod was placed on a pivot. Here you are going to investigate the centre of mass of different objects.

Remember that the centre of mass is the point at which all of the mass of a body can be considered to be concentrated when analysing the motion of the body.

Look at Figure 6.30, which shows two particles, one with mass 3 kg and the other with mass 2 kg. We already know from previous work that the centre of mass will lie somewhere along a straight line connecting the two particles. We can use our knowledge of maths and frames of reference to find the position of the centre of mass.

If the masses of the particles were equal, we could find the centre of mass by finding the mid-point of the line. In this case the centre of mass would be the difference between the two position vectors divided by two:

$$\begin{aligned} \text{Position of centre of mass} &= (A + B)/2 \\ &= \frac{(1 + 3)/2}{(4 + 2)/2} = \begin{bmatrix} 2 \\ 3 \end{bmatrix} \end{aligned}$$

But in this case, the mass of A is bigger than the mass of B. This will mean that the centre of mass is closer to A than to B. We can find the centre of mass by taking into account the different masses of A and B. The position of the centre of mass is given by the vector, C:

$$\begin{aligned} \mathbf{C} &= \frac{(m_1\mathbf{A} + m_2\mathbf{B})}{(m_1 + m_2)} \\ &= \frac{3}{5}\mathbf{A} + \frac{2}{5}\mathbf{B} \\ &= \begin{bmatrix} 3/5 \\ 12/5 \end{bmatrix} + \begin{bmatrix} 6/5 \\ 4/5 \end{bmatrix} = \begin{bmatrix} 9/5 \\ 16/5 \end{bmatrix} = \begin{bmatrix} 1.8 \\ 3.2 \end{bmatrix} \end{aligned}$$

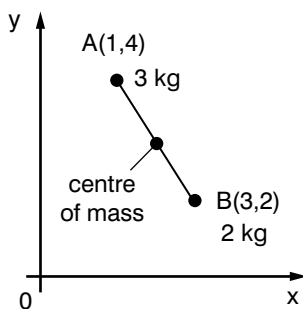

Figure 6.30 Two particles with different masses

We can also express the positions of A and B as vectors from the centre of mass, \mathbf{CA} and \mathbf{CB} , using the same principle. If \mathbf{AB} is the vector of the line going from A to B, then:

$$\mathbf{CA} = -m_2\mathbf{AB}/(m_1 + m_2)$$

$$\mathbf{CB} = m_1\mathbf{AB}/(m_1 + m_2)$$

$$\mathbf{AB} = \mathbf{A} - \mathbf{B} = \begin{bmatrix} 1 \\ 4 \end{bmatrix} - \begin{bmatrix} 3 \\ 2 \end{bmatrix} = \begin{bmatrix} -2 \\ 2 \end{bmatrix}$$

$$\mathbf{CA} = -2/5 \begin{bmatrix} 2 \\ -2 \end{bmatrix} = \begin{bmatrix} -0.8 \\ 0.8 \end{bmatrix}$$

$$\mathbf{CB} = 3/5 \begin{bmatrix} 2 \\ -2 \end{bmatrix} = \begin{bmatrix} 1.2 \\ -1.2 \end{bmatrix}$$

We can extend this principle to find the centre of mass of any system of particles. In the example above we have taken the average of their positions weighted by their masses. We can split up a body into lots of small particles and do the same thing for a body with mass M , the position of the centre of mass is, R :

R = average of (position of each particle multiplied by its mass) divided by the total mass of the whole body.

In Unit 4, you found the centre of mass of a uniform planar object by finding its geometric centre or centroid. We can extend this principle to find the centre of mass of other objects. You can only do this if a body is rigid. When a body is not rigid, the centre of mass moves according to the orientation of the body and this makes calculations very complicated.

So we will be considering rigid objects here – their centres of mass are fixed and it makes the calculations much simpler!

In Unit 4, you learnt how to calculate the position of the centre of mass using the equations:

$$x_{\text{cm}} = \frac{m_1x_1 + m_2x_2 + \dots}{m_1 + m_2 + \dots}$$

$$y_{\text{cm}} = \frac{m_1y_1 + m_2y_2 + \dots}{m_1 + m_2 + \dots}$$

where the distances are the distances from a common reference point.

You can find the centre of mass of each of the objects by finding its centroid. For each object, its centre of mass is in the geometric centre of the shape. For the disc, rod and sphere, the centre of mass is inside the shape, but for the ring, it is outside the shape but in the geometric centre of the ring.

DID YOU KNOW?

The Earth and the Moon have a centre of mass that lies on a straight line connecting them. It is between them, but closer to the Earth than the Moon.

Activity 6.15

Your teacher will give you a variety of objects.

Can you find the centre of mass for each object? Is the position of the centre of mass fixed?

Activity 6.16

Consider the shapes shown in Figure 6.31. Each shape has a uniform density. Where will their centres of mass be? Can you explain why?

(a)

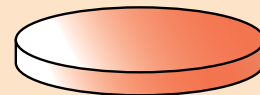

(b)



(c)

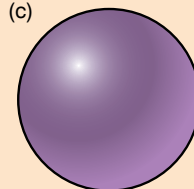

(d)

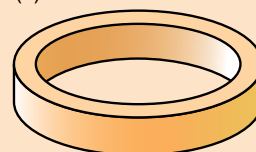

Figure 6.31 Disc (a), rod (b), sphere (c) and ring (d)

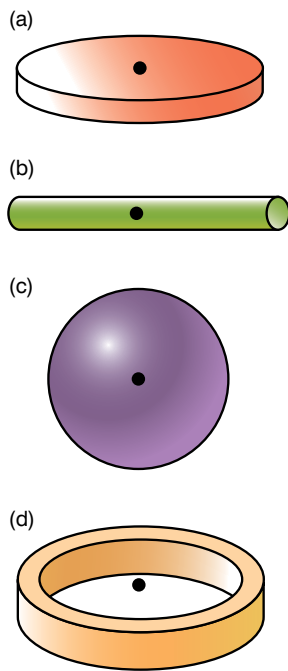

Figure 6.32 Position of centre of mass for (a) disc, (b) rod, (c) sphere and (d) ring

Summary

In this section you have learnt that:

- The position of the centre of mass is fixed in a rigid body.
- The position of the centre of mass of a rigid body is at its geometric centre.

Review questions

1. Work out the position of the centre of mass for each of the following systems.

Each point has a mass of 0.5 kg.

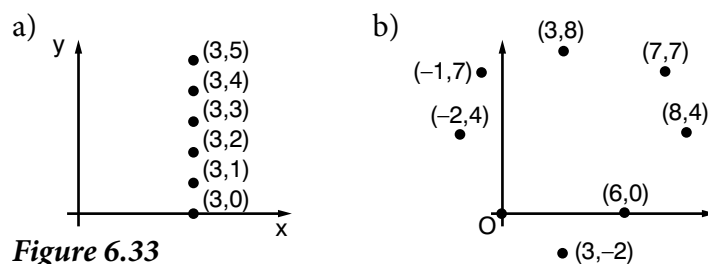

Figure 6.33

2. Which of the shapes in Figure 6.32 does each system resemble?

End of unit questions

1. Construct a glossary of all the key terms in this unit. You could add it to the one you made for Units 1–5.
2. a) What are the similarities between linear and rotational dynamics?
b) What are the differences?
3. What are the rotational laws of motion?
4. A 7.27 kg bowling ball with radius 9.00 cm rolls without slipping down a lane at 4.55 m/s. Calculate the kinetic energy.
5. What is the parallel axis theorem?
6. What is the law of conservation of angular momentum?
7. How can you use the right-hand rule to show the direction of torque and angular momentum?
8. In an isolated system the moment of inertia of a rotating object is doubled. What happens to the angular velocity of the object?
9. A disk is spinning at a rate of 10 rad/s. A second disk of the same mass and shape, with no spin, is placed on the top of the first disk. Friction acts between the two disks until both are eventually travelling at the same speed. What is the final angular velocity of the two disks?
10. Explain, in terms of conservation of angular momentum, why comets speed up as they approach the Sun.
11. Does the centre of mass have to be inside a body?
Explain your answer.
12. How can you find the centre of mass of a rigid body?
13. Describe how you think the law of conservation of angular momentum applies to the falling cat turning over in Figure 6.14.
14. How can you use the right-hand rule to work out the direction of angular momentum?

Contents	
Section	Learning competencies
7.1 Equilibrium of a particle (page 144)	<ul style="list-style-type: none"> • Find the resultant of two or more concurrent forces acting at a point. • Define the term equilibrium. • State the first condition of equilibrium. • Identify and label the forces and torques acting in problems related to equilibrium. • Apply the first condition of equilibrium to solve equilibrium problems.
7.2 Moment or torque of a force (page 146)	<ul style="list-style-type: none"> • Distinguish between coplanar and concurrent forces. • Draw free body diagrams to show all the forces acting.
7.3 Conditions of equilibrium (page 150)	<ul style="list-style-type: none"> • Differentiate static equilibrium from dynamic equilibrium. • State the second condition for equilibrium. • Verify the second condition for equilibrium is valid about any arbitrary axis of rotation. • Describe the difference among the terms stable, unstable and neutral equilibrium. • Explain why objects are stable, unstable and neutral. • Explain methods of checking stability, instability and neutrality of rigid bodies. • Describe the equilibrium conditions for a body acted on by coplanar forces. • Verify by experiment the conditions necessary for the equilibrium of a set of non-concurrent forces. • State the conditions for rotational equilibrium.
7.4 Couples (page 155)	<ul style="list-style-type: none"> • Define the term couples. • Describe the rotational effects of couples on the rigid body. • Solve problems involving the equilibrium of coplanar forces.

In Grade 10, you learnt about equilibrium and the conditions of equilibrium in rotational motion. Earlier in this book, you learnt more about moments and torque. In this unit, we will see how moments, torque and equilibrium are linked.

KEY WORDS

equilibrium a body is in equilibrium when the net force and net moment on the particle are zero

concurrent forces forces that all pass through the same point

7.1 Equilibrium of a particle

By the end of this section you should be able to:

- Find the resultant of two or more concurrent forces acting at a point.
- Define the term equilibrium.
- State the first condition of equilibrium.
- Identify and label the forces and torques acting in problems related to equilibrium.
- Apply the first condition of equilibrium to solve equilibrium problems.

Newton's first law of motion states that a particle will continue in its state of uniform motion along straight line or rest unless it is acted on by a force. We can restate Newton's first law to give the **equilibrium** of a particle, which is that in the absence of net external force a particle is said to be in equilibrium. If a net force acts on a particle, it is no longer in equilibrium and will move according to Newton's second law of motion.

In this section we will consider **concurrent forces**, which are forces that all pass through the same point.

Consider a situation where three forces are acting on a body, as shown in Figure 7.1. The forces are concurrent, but is the body in equilibrium? For the body to be in equilibrium the net force must be zero.

We can resolve the vectors into their components and then add the components. If the force to the left is equal to the force to the right, and the force up is equal to the force down, then the net force is zero and the body is in equilibrium.

We can also use vector addition to find the net force. In Unit 2, you learnt how to add vectors by drawing them head to tail. If we draw the force vectors in Figure 7.1 head to tail and they form a triangle, then the net force is zero, as shown in Figure 7.2. This also applies to any number of concurrent forces – if they form a closed shape when drawn, the net force is zero.

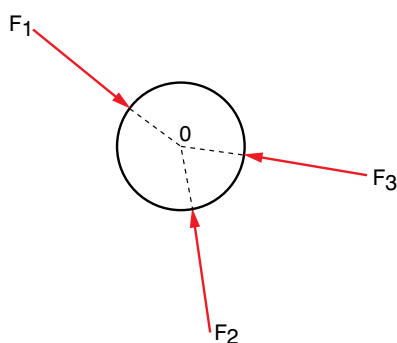

Figure 7.1 Concurrent forces acting on a body

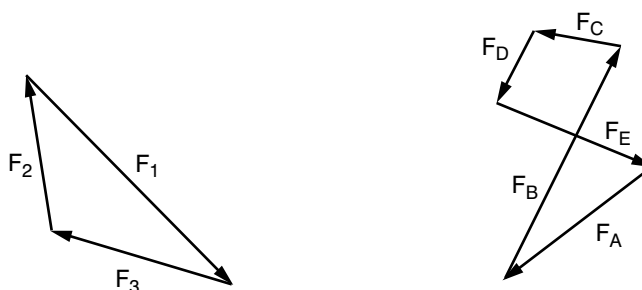

Figure 7.2 When a set of concurrent forces form a closed shape, the net force is zero.

We can also express this mathematically. If the sum of all the forces acting on a body in the x-direction is zero and the sum of the forces acting on a body in the y-direction is zero, the body will be in equilibrium:

$$\Sigma F_x = 0 \text{ and } \Sigma F_y = 0$$

This is the first condition of equilibrium.

We can also express this in vector terms:

$$\Sigma \mathbf{F} = 0$$

Worked example 7.1

Three concurrent forces are shown in Figure 7.3. Are they in equilibrium?

If the forces are in equilibrium, then $\Sigma F_x = 0$ and $\Sigma F_y = 0$

First resolve each of the forces into its vertical and horizontal components:

$$A_{\text{hor}} = 5.39 \cos 21.8^\circ = 5.00 \text{ N}$$

$$A_{\text{vert}} = -5.39 \sin 21.8^\circ = -2.00 \text{ N}$$

$$B_{\text{hor}} = -6.32 \cos 18.4^\circ = -6.00 \text{ N}$$

$$B_{\text{vert}} = 6.32 \sin 18.4^\circ = -2.00 \text{ N}$$

$$C_{\text{hor}} = 4.12 \cos 76.0^\circ = 1.00 \text{ N}$$

$$C_{\text{vert}} = 4.12 \sin 76.0^\circ = 4.00 \text{ N}$$

Add the horizontal components: $5.00 \text{ N} + -6.00 \text{ N} + 1.00 \text{ N} = 0 \text{ N}$

Add the vertical components: $-2.00 \text{ N} + -2.00 \text{ N} + 4.00 \text{ N} = 0 \text{ N}$

The net force both horizontally and vertically is zero so the body is in equilibrium.

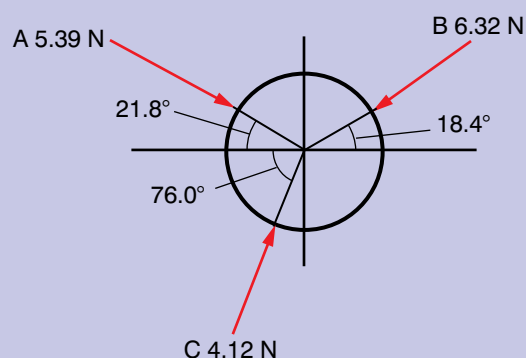

Figure 7.3

Activity 7.1

You are going to investigate forces in equilibrium. Attach three newtonmeters together. Attach the other end of each newtonmeter to a heavy block (Figure 7.4).

Record the magnitude of the three forces and the angles of the forces.

Move the blocks and measure the forces and angles again.

Repeat a couple more times.

Resolve each force into its components and add them up. Do they show that the system is in equilibrium?

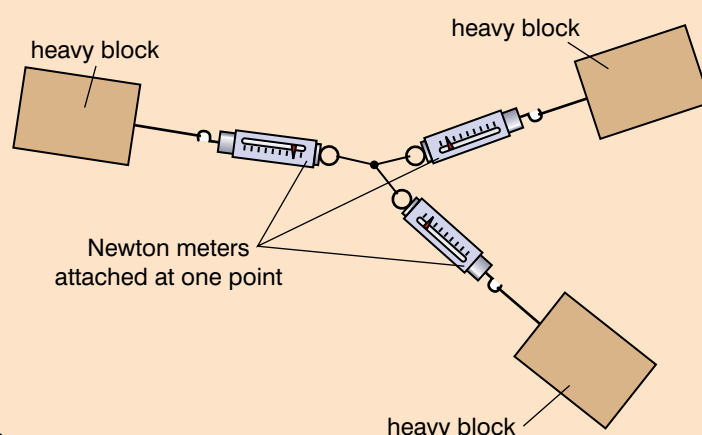

Figure 7.4

If a body is not in equilibrium, the body will accelerate in the direction of the net force.

Summary

In this section you have learnt that:

- For a set of concurrent forces acting on a body, if the net force is zero, the body is in equilibrium and this is the first condition of equilibrium.
- Vector addition can be used to find the sum of the forces.

Review questions

1. Find if these set of concurrent forces are in equilibrium by drawing the forces head to tail.
 - a) $A \begin{bmatrix} 4 \\ 5 \end{bmatrix}$ N, $B \begin{bmatrix} -3 \\ -2 \end{bmatrix}$ N and $C \begin{bmatrix} -2 \\ -3 \end{bmatrix}$ N
 - b) $D \begin{bmatrix} -6 \\ 1 \end{bmatrix}$ N, $E \begin{bmatrix} 2 \\ 3 \end{bmatrix}$ N and $F \begin{bmatrix} 4 \\ -4 \end{bmatrix}$ N
2. Are these concurrent vectors in equilibrium? Use vector addition to check.
 $G \begin{bmatrix} -6 \\ 2 \end{bmatrix}$, $H \begin{bmatrix} 1 \\ 1 \end{bmatrix}$ and $I \begin{bmatrix} 5 \\ -3 \end{bmatrix}$
3. Are these three concurrent vectors in equilibrium? Find their horizontal and vertical components to check.

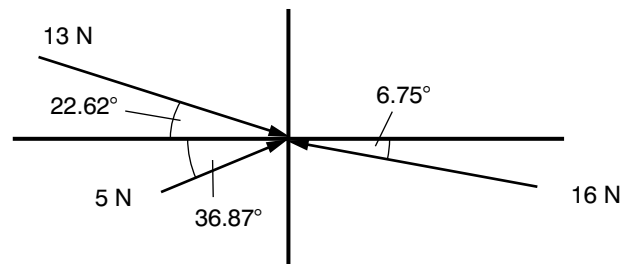

Figure 7.5

KEY WORDS

moment of a force *the force multiplied by the perpendicular distance from the point about which the moment is being measured*

coplanar forces *a set of forces that act in the same plane*

7.2 Moment of force or torque

By the end of this section you should be able to:

- Distinguish between coplanar and concurrent forces.
- Draw free body diagrams to show all the forces acting.

In Section 7.1 we looked at concurrent forces. But what happens when a set of forces is not concurrent? Look at the forces shown in Figure 7.6. Forces A, B and C are acting on a rigid body. Forces B and C are equal and opposite. As they are acting on the same point, they balance out. Force A is acting at a point 20 cm from the other two. As the body is rigid, this force will try to turn the body anti-clockwise about the point X. The turning effect is known as a **moment** or torque.

The forces shown in Figure 7.6 are all in the plane of the paper – they are said to be **coplanar**.

You have already been introduced to moments and torque. In Unit 4 you looked at the moments around a see-saw and in Unit 6 you looked at torque about a point. Moments and torque are essentially the same thing, but moments deal with statics and torque is to do with rotational motion.

Activity 7.2

What examples of moments and torque can you see in the classroom?

What examples can you think of that you come across in everyday life?

When we analyse moments, we take the moments about an axis, both clockwise and anticlockwise. Anticlockwise is taken to be positive and clockwise negative.

The axis is perpendicular to the plane of the paper. The moment also depends on which axis you choose to take moments about.

Worked example 7.3

What are the moments about P and Q in Figure 7.7?

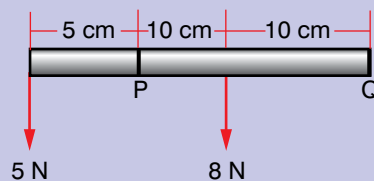

Figure 7.7

Use the equation: $\tau = Fd$

Where τ is the momentum of force, F is the component of the force perpendicular to the displacement and d is the displacement from the axis of rotation.

Clockwise moment about P = $8 \text{ N} \times 0.1 \text{ m} = 0.8 \text{ N m}$

anti-clockwise moment about P = $5 \text{ N} \times 0.05 \text{ cm} = 0.25 \text{ N m}$

net moment = $0.25 \text{ N m} - 0.8 \text{ N m} = -0.55 \text{ N m}$, that is clockwise about P

Anti-clockwise moment about Q = $5 \text{ N} \times 0.25 \text{ m} + 8 \text{ N} \times 0.1 \text{ m} = 1.25 \text{ N m} + 0.8 \text{ N m} = 2.05 \text{ N m}$

There is no clockwise moment about Q, so the net moment is $+2.05 \text{ N m}$, that is, anticlockwise about Q.

Sometimes forces are not perpendicular to the bar. You should remember from Unit 6 that the moment or torque is given by the vector product of the force and displacement from the axis of rotation:

$$\boldsymbol{\tau} = \mathbf{r} \times \mathbf{F} = rF \sin \theta$$

where θ is the angle between \mathbf{r} and \mathbf{F}

Worked example 7.2

What is the moment about point X in Figure 7.6?

Forces B and C are equal and opposite, so we do not need to consider them.

Moment = force \times perpendicular distance
 = $20 \text{ N} \times 0.2 \text{ m} = 4 \text{ N m}$

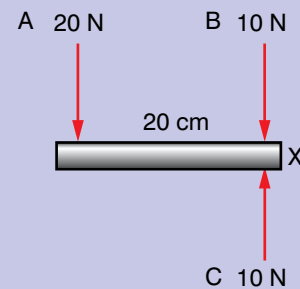

Figure 7.6 Forces acting on a rod

Activity 7.3

You are going to investigate the equilibrium of a stack of objects.

Make a stack of objects such as coins or other small flat objects.

What happens to the stability of the pile as you increase the number of objects?

Explain this in terms of the centre of mass and moments.

This means that we do not need to consider any component of the force that acts in the same direction as the displacement from the axis of rotation. The angle between \mathbf{r} and \mathbf{F} is zero, so:

$$\tau = rF \sin 0^\circ = rF \times 0 = 0$$

Worked example 7.4

What are the moments about R and S in Figure 7.8?

Use the equation $\tau = Fd \sin \theta$ where τ is the moment, F is the force, d is the displacement from the axis of rotation and θ is the angle between the force and the displacement.

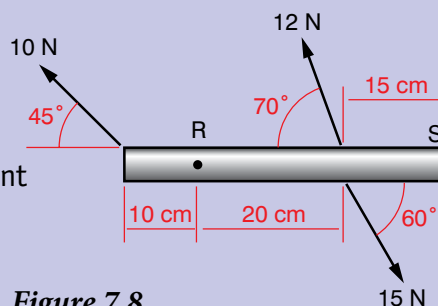

Figure 7.8

Taking moments about R:

Clockwise moment = $0.1 \text{ m} \times 10 \text{ N} \times \sin 45^\circ + 0.2 \text{ m} \times 15 \text{ N} \times \sin 60^\circ = 0.71 \text{ N m} + 2.60 \text{ N m} = 3.31 \text{ N m}$

Anticlockwise moment = $0.2 \text{ m} \times 12 \text{ N} \times \sin 70^\circ = 2.26 \text{ N m}$

Net moment = anticlockwise moment – clockwise moment = $2.26 \text{ N m} - 3.31 \text{ N m} = -0.05 \text{ N m}$, that is clockwise about R

Taking moments about S:

Clockwise moment = $0.45 \text{ m} \times 10 \text{ N} \times \sin 45^\circ + 0.15 \text{ m} \times 12 \text{ N} \times \sin 70^\circ = 3.18 \text{ N m} + 1.69 \text{ N m} = 4.87 \text{ N m}$

Anticlockwise moment = $0.15 \text{ m} \times 15 \text{ N} \times \sin 60^\circ = 1.95 \text{ N m}$

Net moment = $1.95 \text{ N m} - 4.87 \text{ N m} = -2.92 \text{ N m}$, that is anticlockwise about S.

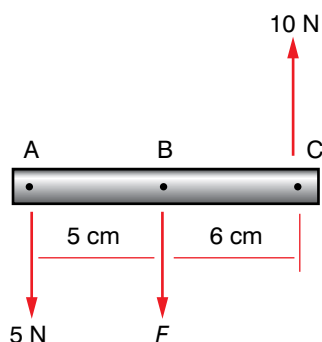

Figure 7.9 Choosing the right axis can help you when solving problems with moments.

When solving problems, you can choose which axis you take moments around. Sometimes you need to choose your axes carefully – it can help to eliminate forces that you do not know. For example, look at Figure 7.9. You could take moments about axes A, B or C. If you take moments about points A and C, you need to know force F , or be able to calculate it. If you take moments about point B, you do not need to know force F because it is over the pivot, and hence does not have any turning effect.

Sometime you do need to choose the pivot to include the unknown force. For example, if you were asked to find force F from the information you are given, then you need to make sure that you choose a pivot where the moments do involve F .

Worked example 7.5

Three forces act on a bar as shown in Figure 7.9. There is a net torque of 2.8 N m anti-clockwise around the axis at A. What is the size of the force at B?

As the axis is at A, the force of 5 N does not have any effect.

Use the equation: $\tau = Fd$

where τ is the momentum, F is the component of the force perpendicular to the displacement and d is the displacement from the axis of rotation.

Moment about A = $10 \text{ N} \times 0.11 \text{ m} - F \text{ N} \times 0.05 \text{ m} = 2.8 \text{ N m}$

So $F \times 0.05 \text{ m} = 1.1 \text{ N m} - 2.8 \text{ N m}$

$F = -1.7 \text{ N m} / 0.05 \text{ m} = -34 \text{ N}$

The negative sign indicates that the force is in the clockwise direction, which means that it would be 34 N downwards.

Activity 7.4: Experimentally determining equilibrium

You are going to look at how equilibrium can be used in toys. Look at the balancing toy shown in Figure 7.10.

This toy is balanced on two points which are just behind the wheels. If you push the tail down and let go, the toy will swing back and act like a pendulum.

Use your knowledge of moments (and energy transfers from Unit 5) to analyse the motion of the toy.



Figure 7.10 Balancing toy

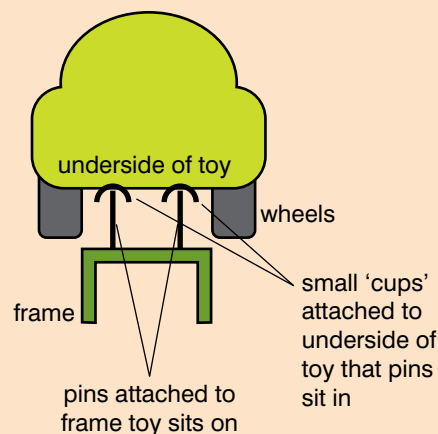

Figure 7.11

Summary

In this section you have learnt that:

- Coplanar forces act in the same plane.
- The moment of a force about an axis is the force multiplied by the perpendicular distance of the force from the axis.

Project work

Research the effects of torque and equilibrium on taps, doors, handlebars and bicycles. Write a report on your findings. You could also research torque in simple electric motors and moving coil meters.

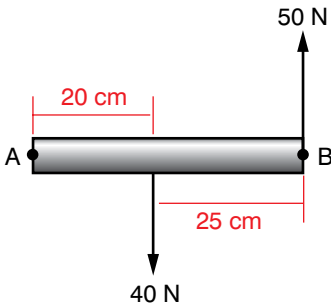

Figure 7.12

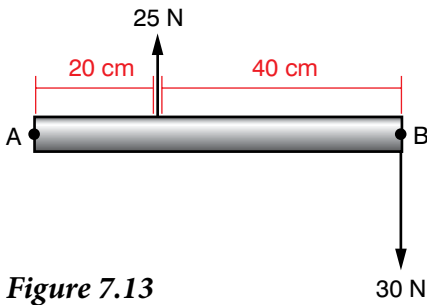

Figure 7.13

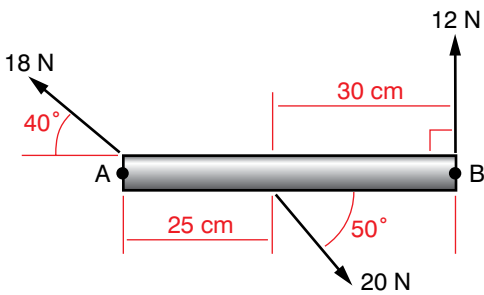

Figure 7.14

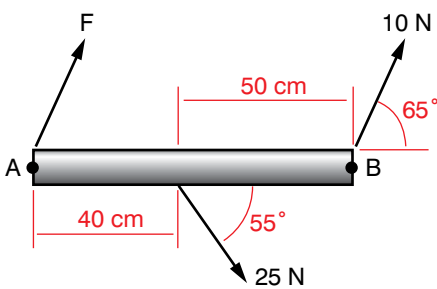

Figure 7.15

Review questions

- Two forces act on a bar as shown in Figure 7.12.
What is the net torque about:
 - axis A
 - axis B?
- Two forces act on a bar as shown in Figure 7.13.
a) What is the net torque about:
 - axis A
 - axis B.
 b) What weight would need to be added to A to give a net torque of 3.5 N m anti-clockwise around axis B?
- Three forces act on a bar as shown in Figure 7.14.
What is the net torque about:
 - axis A
 - axis B?
- Three forces act on a bar as shown in Figure 7.15.
a) Calculate the net torque about axis A.
b) The net torque about axis B is zero. Calculate the vertical component of force F.
c) Do you have enough information to calculate the magnitude of force F? Explain your answer.

7.3 Conditions of equilibrium

By the end of this section you should be able to:

- Differentiate static equilibrium from dynamic equilibrium.
- State the second condition for equilibrium.
- Verify the second condition for equilibrium is valid about any arbitrary axis of rotation.
- Describe the difference among the terms stable, unstable and neutral equilibrium.
- Explain why objects are stable, unstable and neutral.
- Explain methods of checking stability, instability and neutrality of rigid bodies.
- Describe the equilibrium conditions for a body acted on by coplanar forces.
- Verify by experiment the conditions necessary for the equilibrium of a set of non-concurrent forces.
- State the conditions for rotational equilibrium.

In Section 7.1, we looked at the equilibrium of concurrent forces. In Section 7.2, we considered what happens when the forces are no longer concurrent and become coplanar. Here we will look at the conditions that are needed for coplanar forces to be in equilibrium.

For a body to be in equilibrium, two conditions must be satisfied:

- the net force (or the sum of the force vectors) must be zero
- the net torque must be zero.

This will only tell you that the body is in equilibrium – it could be moving at a steady velocity or it could be at rest. If a body is not moving and there are no net forces or torque on the body, it is in **static equilibrium**.

If the body is moving and there are no net forces or no net torque acting on the body, there is no net acceleration. The body will continue to move at the same velocity. The body is in **dynamic equilibrium**.

We can also express the two conditions of equilibrium mathematically:

$$\text{First condition: } \Sigma \mathbf{F} = 0$$

$$\text{Second condition: } \Sigma \boldsymbol{\tau} = 0$$

If we know the forces and distances acting on a system, we can take moments about any point to see if the system is in equilibrium.

KEY WORDS

static equilibrium *type of equilibrium that occurs when a body is at rest and there is no net force or net torque acting on it*

dynamic equilibrium *type of equilibrium that occurs when a body is moving at a steady velocity and there is no net force or net torque acting on it*

Worked example 7.6

Three forces act on a bar as shown in Figure 7.16. Is the bar in equilibrium?

Work out the net force.

The net force is $80 \text{ N} - 50 \text{ N} - 30 \text{ N} = 0 \text{ N}$

Work out the net torque.

Use $\tau = rF$

Taking moments about A: $80 \text{ N} \times 0.15 \text{ m} - 30 \text{ N} \times 0.4 \text{ m} = 12 \text{ N m} - 12 \text{ N m} = 0 \text{ N m}$

Taking moments about B anticlockwise: $50 \text{ N} \times 0.15 \text{ m} = 7.5 \text{ N m}$

Taking moments about B clockwise: $30 \text{ N} \times 0.25 \text{ m} = 7.5 \text{ N m}$

So the net torque about B is zero.

Taking moments about C: $50 \text{ N} \times 0.4 \text{ m} - 80 \text{ N} \times 0.25 \text{ m} = 20 \text{ N m} - 20 \text{ N m} = 0 \text{ N}$.

The net torque is zero.

As the net force and net torque is zero, the system is in equilibrium.

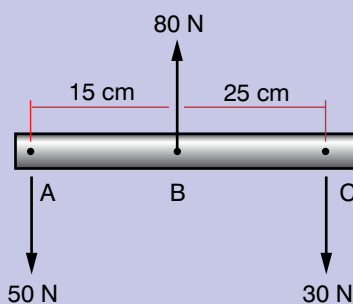

Figure 7.16

Activity 7.5

You are going to verify the conditions necessary for equilibrium of a set of forces.

You have a metre stick, some metre stick knife-edge clamps, some weight hangers, a set of weights, and a balance and weights.

How can you use this apparatus to verify the conditions necessary for equilibrium of a set of coplanar forces?

Plan your experiment, carry it out and write a report. You can use the writing frame in Section 1.4, pages 19–20 to help you.

If a system of coplanar forces is in equilibrium, we can take moments about any point and find that the net torque is zero. Remember that when you take moments about a point, you do not include any forces acting at that point. We could also take moments from somewhere that is not on the bar. For example, if we take moments about a point that is 10 cm to the left of A, the moments are:

$$80 \text{ N} \times 0.25 \text{ m} - 50 \text{ N} \times 0.1 \text{ m} - 30 \text{ N} \times 0.5 \text{ m} \\ = 20 \text{ N m} - 5 \text{ N m} - 15 \text{ N m} = 0 \text{ N m}$$

The net torque is still zero.

The bottles in Figure 7.17 show three types of equilibrium. When a bottle is standing upright, it is in stable equilibrium. As long as the centre of mass stays inside a point vertically above the base, it will not fall over. If a small moment acts on the top of the bottle and pushes it slightly, when the force is removed the bottle will fall back into its stable equilibrium position.

When a bottle is lying on its side, it is in neutral equilibrium. If a small moment acts perpendicular to the top surface of the bottle, it will roll. When the moment is removed, the bottle will come to rest in a new position because of the force of friction between the bottle and the surface, still lying on its side. There is an infinite number of positions that the bottle could be in.

When a bottle is standing on its neck, it is in unstable equilibrium. A small torque acting on the bottle will cause it to fall over because the centre of mass does not have to move very far until it is over a point which is outside what is now the base of the bottle.



Figure 7.17 Stable, neutral and unstable equilibrium of a bottle

Activity 7.6

Figure 7.18 shows a bar that is free to rotate about a hinge at its left-hand end. It is held horizontally by a force. The torque due to the force of gravity is balanced by the force F .

Consider what happens to the force F and the force H_{vert} as the force F is moved along the rod in Figure 7.18a.

In Figure 7.18b, the force is fixed at the opposite end of the rod to the hinge. Consider what happens to the forces F , H_{vert} and H_{hor} as the angle of F is varied.

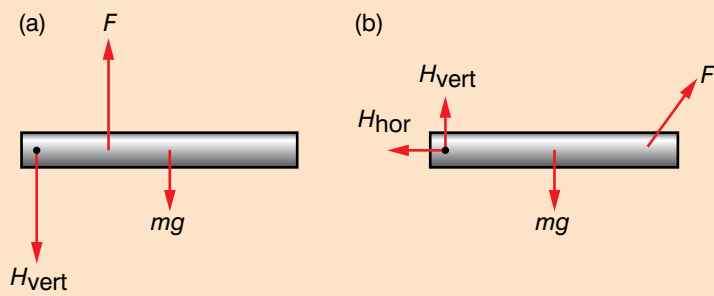

Figure 7.18 Bar free to rotate about left end: (a) force F moves along rod; (b) angle of force F varies

Worked example 7.7

A ladder rests against a wall at an angle of 60° to the horizontal. The ladder is 8 m long and has a mass of 35 kg. The wall is considered to be frictionless.

Find the force that the floor and wall exert against the ladder.

There is no vertical component of force from the wall because it is frictionless, so the force from the wall is horizontal. There are two components to the force from the floor: a horizontal force from friction with the floor and a vertical normal component.

Draw a diagram to show the forces (Figure 7.19).

As the ladder is in equilibrium, the sum of the forces is zero.

$$\Sigma \mathbf{F} = 0$$

$$\text{Vertical component: } N_f - mg = 0$$

where N_f is the normal force from the floor.

$$\text{Horizontal component: } N_w - F = 0$$

where N_w is the normal force from the wall.

Similarly, the moments taken around any axis will be zero $\Sigma \tau = 0$.

Use the base of the ladder and taking the anticlockwise direction to be positive:

$$mg \times l/2 \times \cos 60^\circ - N_w \times l \times \sin 60^\circ = 0$$

From the force equations we can see that $N_f = mg$ and $N_w = F$

Substituting for N_w and rearranging the torque equation gives:

$$F = mg \cos 60^\circ / 2 \sin 60^\circ = mg/2 \tan 60^\circ \\ = (35 \text{ kg} \times 9.8 \text{ m/s}^2) / (2 \times 1.732) = 99 \text{ N}$$

$$N_f = mg = 35 \text{ kg} \times 9.8 \text{ m/s}^2 = 343 \text{ N}$$

$$\text{So total force from the floor is } \begin{bmatrix} -99 \\ 343 \end{bmatrix} \text{ N}$$

$$\text{Or: } F = \sqrt{(99^2 + 343^2)} \text{ at an angle of } \tan^{-1}(343/99) \\ = 357 \text{ N at an angle of } 73.9^\circ \text{ to the horizontal.}$$

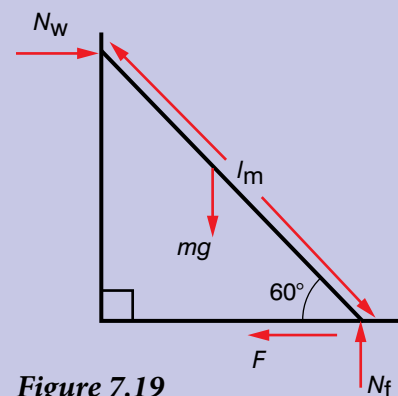

Figure 7.19

Activity 7.7

Design a simple children's toy that will not fall over. When you push this toy over, it should bounce back up to the vertical.

What are the characteristics it needs for it to bounce back up when it is pushed over?

You will need to use what you have learnt about equilibria, moments and centre of mass.



Figure 7.21 Part of Fasilidas's palace in Gonder. Are the balconies in equilibrium?

Rotational equilibrium

In Unit 6 you learnt that you can apply the equations and laws of linear motion to rotational motion. In the same way, the conditions of equilibrium can be applied to rotational motion. If a body is in rotational equilibrium, the sum of all the external torques acting on the body must be zero.

Worked example 7.8

Is the body shown in Figure 7.20 in rotational equilibrium?

The anticlockwise torque is Fx .

The clockwise torque is Fx .

So the net torque is 0 and the body is in equilibrium.

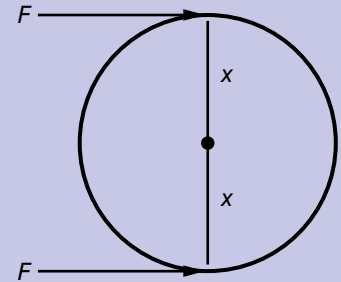

Figure 7.20

Summary

In this section you have learnt that:

- The conditions for a system of coplanar forces to be in equilibrium are that the net force and net torque must be zero.
 $\Sigma \mathbf{F} = 0$ and $\Sigma \tau = 0$
- When a system is in equilibrium, it does not matter which axis you take moments about.
- In rotational equilibrium, the sum of all the external torques acting on the body must be zero.

Review questions

1. A bar has a 20 N weight at one end, as shown in Figure 7.22. You have a weight of 15 N to hang somewhere on the bar so that the bar is in equilibrium. Where would you hang the 15 N weight on each of these bars? Consider the bar to have no mass.

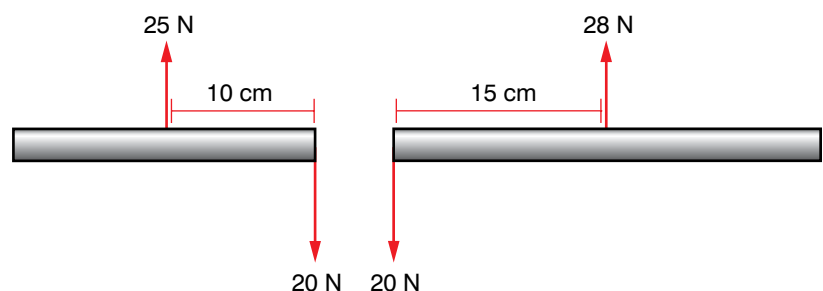

Figure 7.22

2. Figure 7.23 shows a sign that is hanging from a horizontal bar. The bar is fixed to the wall at P, and is free to rotate. There is a wire strung from the outer end of the bar to a point 60 cm above the pivot. The sign and the bar have a mass of 2 kg. Assume that the wire is massless.

The system is in equilibrium.

What is the size of the force in the wire?

3. A ladder, of length 3 m and mass 20 kg, leans against a smooth, vertical wall so that the angle between the horizontal ground and the ladder is 60°

Find the magnitude of the friction and normal forces that act on the ladder if it is in equilibrium.

4. A uniform rod of length 2 m and mass 5 kg is connected to a vertical wall by a smooth hinge at A and a wire CB, as shown in Figure 7.24.

A 10 kg mass is attached to D. Find:

- the tension in the wire
- the magnitude of the force at the hinge A.

(Hint: think about the position of the centre of mass.)

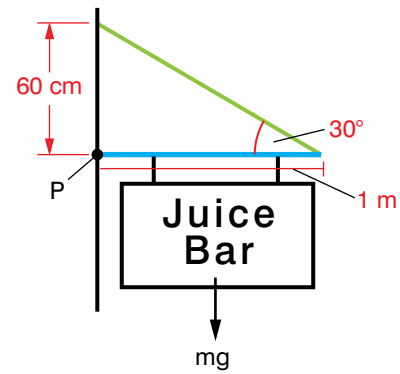

Figure 7.23

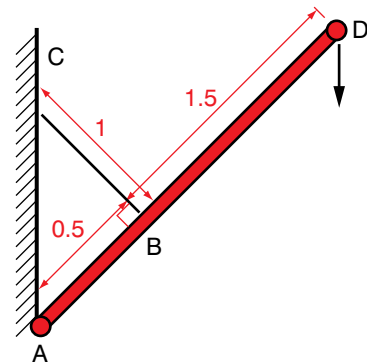

Figure 7.24

7.4 Couples

By the end of this section you should be able to:

- Define the term couples.
- Describe the rotational effects of couples on the rigid body.
- Solve problems involving the equilibrium of coplanar forces.

Sometimes we get two equal and opposite forces acting on a body, as shown in Figure 7.25. These two forces are known as a **couple**.

Compare this with the forces acting on the body in Figure 7.20. In Figure 7.20, the forces produced torques in opposite directions. In Figure 7.25, the forces produce torques that act in the same direction.

Earlier you saw that the moment about a point depends on the point around which you choose to take the moment.

KEY WORDS

couples a set of forces with a resultant moment but no net force

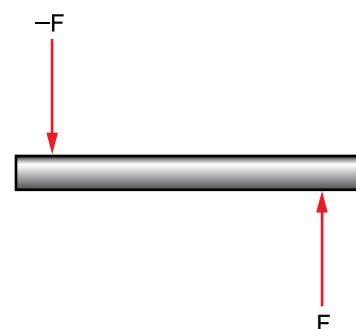

Figure 7.25 A couple

DID YOU KNOW?

When you turn on a tap like the one shown in Figure 7.26, the forces used to turn the handle are a couple.



Figure 7.26 The forces used to turn this tap on are a couple

Activity 7.8

In a small group, discuss what examples of couples you can think of in everyday life.

Report the results of your discussion to the rest of the class.

Worked example 7.10

Two forces of 20 N act as a couple. The forces act at a distance of 10 cm from the centre of rotation. What is the torque produced by the couple?

Forces act at 10 cm from centre of rotation, so they are 20 cm apart.

$$\text{Torque} = Fd = 20 \text{ N} \times 0.2 \text{ m} = 4 \text{ N m}$$

Worked example 7.9

Let us consider the moments about three separate axes, as shown in Figure 7.27.

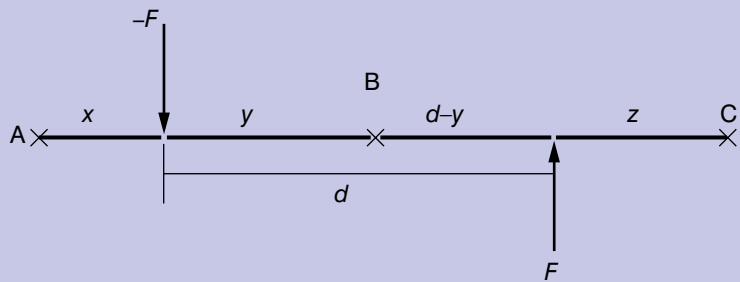

Figure 7.27 Taking moments about three points for a couple

Let's take the moment of forces about points A, B and C:

$$\text{Moment about A} = -Fx + F(x + d) = Fd$$

$$\text{Moment about B} = Fy + F(d - y) = Fd$$

$$\text{Moment about C} = -F(d + z) + Fz = Fd$$

So we can see (from the worked example) that the moment of a couple is independent of the axis we take the moment around, as long as the axis is perpendicular to the plane of the couple.

The properties of a couple are:

- the linear resultant of a couple is zero (e.g. $F + -F = 0$)
- the moment of a couple is not zero and has the same magnitude irrespective of the position of the perpendicular axis chosen.

If a set of coplanar forces satisfies these two conditions, it is said to be a couple.

Summary

In this section you have learnt that:

- A couple is a set of forces with a resultant moment but no net force.
- The torque of a couple is the force multiplied by the distance between the forces.

Review question

1. Calculate the torque for the following couples:
 - a) 50 N, 40 cm distance perpendicular to axis of rotation.
 - b) 120 N, 5 cm distance perpendicular to axis of rotation.

End of unit questions

- Construct a glossary of all the key terms in this unit. You could add it to the one you made for Units 1–6.
- What is torque?
- What are the conditions for equilibrium?
 - If an object is in equilibrium, is it also in static equilibrium? Explain your answer.
- A 20 kg box is suspended from the ceiling by a rope that weighs 1 kg. Find the tension at the top of the rope.
- A particle is acted on by the forces as shown in Figure 7.28. Resolve the forces horizontally and vertically to find the magnitude of the forces P and θ .
- A particle is at equilibrium on inclined plane under the forces shown in Figure 7.29. Find
 - the magnitude of the force P
 - the magnitude of the angle θ .
- A particle of mass 3 kg is held in equilibrium by two light unextensible strings. One string is horizontal, as shown in Figure 7.30. The tension in the horizontal string is PN and the tension in the other string is θ N. Find
 - the value of θ
 - the value of P .
- What are the conditions for there to be no rotation of a body?
- What are the differences between concurrent and coplanar forces?
- What are the differences between static and dynamic equilibrium?
- A car is driving along a road at a speed of 20 m/s.
 - What forces will be acting on the car?
 - What additional information do you need to know to show that the car is in a dynamic equilibrium?

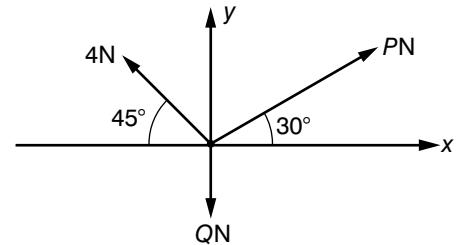

Figure 7.28

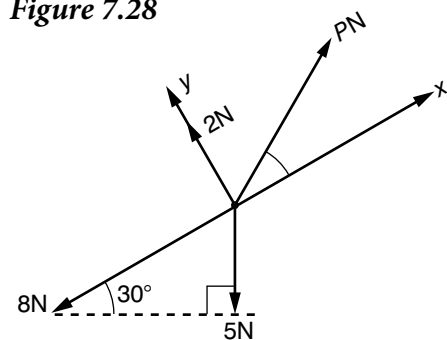

Figure 7.29

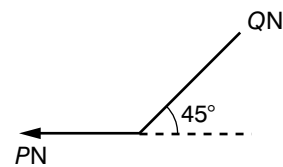

Figure 7.30

Contents

Section	Learning competencies
8.1 Elastic behaviour (page 159)	<ul style="list-style-type: none"> • Define the terms elastic limit, stress, strain, Young's modulus, shear modulus. • State Hooke's law. • Carry out calculations involving stress, strain, Young's modulus and the energy stored in a stretched material.
8.2 Fluid statics (page 166)	<ul style="list-style-type: none"> • Define the terms density, atmospheric pressure, absolute pressure, pressure, volume. • Describe the concepts related to hydraulic and pneumatic systems. • State and apply Archimedes's principle. • Define surface tension and surface energy. • Define the angle of contact and account for the shapes of the surfaces of liquids. • Determine the relationship for capillary rise and use it to solve problems.
8.3 Fluid dynamics (page 175)	<ul style="list-style-type: none"> • Define the terms laminar and turbulent flow, flow rate. • Identify factors affecting laminar flow and give examples. • Identify factors that affect the streamlining of cars, boats and planes. • Define the Reynolds number. • State Bernoulli's principle. • Explain applications of Bernoulli's principle. • Use Bernoulli's equation to solve problems. • State Stokes's law and use it to solve problems. • Use the equation of continuity to solve problems.
8.4 Heat, temperature and thermal expansion (page 184)	<ul style="list-style-type: none"> • Define the terms calorimetry, phase, phase change, phase diagram, state variable, critical point, triple point, latent heat, heat capacity, specific heat capacity. • Distinguish between heat, temperature, internal energy and work. • State the units for heat, heat capacity, specific heat capacity and latent heat. • Explain the factors that determine the rate of heat flow through a material. • Describe the thermal expansion of solids in terms of the molecular theory of matter. • Carry out calculations involving expansivity. • Solve problems involving thermal conductivity. • Describe experiments to measure latent heat.

8.1 Elastic behaviour

By the end of this section you should be able to:

- Define the terms elastic limit, stress, strain, Young's modulus, shear modulus.
- State Hooke's law.
- Carry out calculations involving stress, strain, Young's modulus and the energy stored in a stretched material.

You have already learnt about forces. Sometimes forces can deform a body (push it out of shape). You need two equal but opposite forces to cause a body to deform. A single force would merely cause it to start moving with increasing speed.

Stress–strain relation

You need to know about four main types of deformation – tensile deformation, torsional deformation, shear deformation and compressional deformation. Notice that a single force acting on its own will accelerate a body, not deform it.

Any deformation may be elastic, or it may be plastic. With **elastic deformations**, when you remove the forces that caused the deformation, the body goes back to its original dimensions.

With **plastic deformations**, irreversible changes occurred while the body was being deformed. In a metal, layers of atoms may have slipped over one another, for example. It no longer returns to its original dimensions when the forces are removed. Note that there is a difference in elasticity between metallic and non-metallic solids. For all materials there is an **elastic limit** – beyond this limit the material will be permanently deformed. The elastic limit

KEY WORDS

elastic deformations

deformations where, when forces that caused deformation are removed, body goes back to its original dimensions

plastic deformations

deformations where irreversible changes occur when the body is being deformed

elastic limit *point beyond which all materials are permanently deformed*

Worked example 8.1

Find the tensile stress when a force of 4.9 N acts over a cross-sectional area of $2 \times 10^{-3} \text{ m}^2$.

Tensile stress (N/m^2)	Force (N)	Cross-sectional area (m^2)
?	4.9	2×10^{-3}

$$\begin{aligned} \text{Use tensile stress} &= \frac{F}{A} \\ &= 4.9 / 2 \times 10^{-3} \text{ m} = 2450 \text{ N m}^{-2} \end{aligned}$$

Activity 8.1: Experiencing deforming forces

Lay a 1 m length of rubber on a bench: try stretching it using first one hand then two. Describe the difference between the two situations.

Different types of deformation can be produced, depending on how these forces are applied. Figure 8.1 shows some examples.

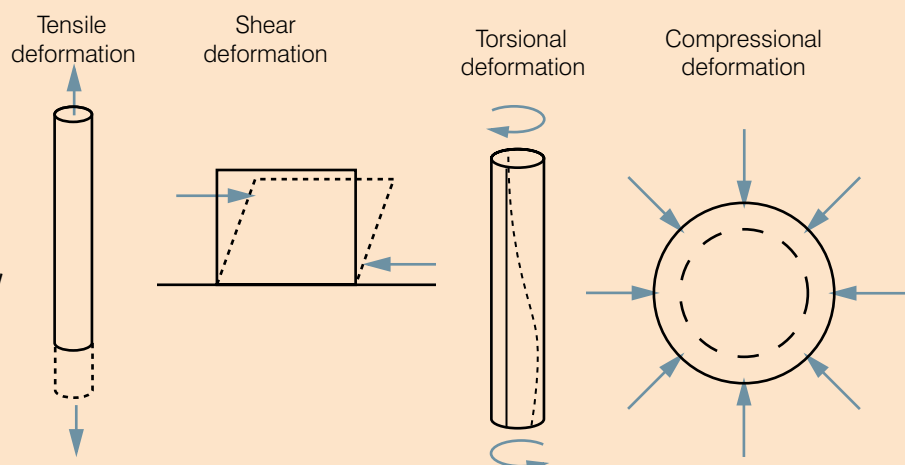

Figure 8.1 Different types of deformation

KEY WORDS

tensile stress *tensile force F divided by the cross-section area A of the wire*

$$\text{tensile stress} = \frac{F}{A}$$

depends on the internal structure of the material. Steel (a metal), for example, has a low elastic limit, whereas rubber (a non-metal) has a very much higher limit.

Activity 8.2 shows us what force was needed to stretch the particular wire we tested. In general, how easily does copper stretch?

To take the applied force alone as a measure of how much we are *trying* to deform it is not sufficient. A force of 100 N would have hardly any effect on a thick copper bar, but that same force might break a thin wire. To compare like with like, we use as the measure the **tensile stress** being applied. This is defined to be the tensile force F divided by the area of cross-section A of the wire.

$$\text{Tensile stress} = \frac{F}{A}$$

The units of tensile stress will be N/m^2 .

For the measure of how much the copper has deformed as a result, it is not enough to consider just the wire's extension x . To cause

Activity 8.2: Exploring tensile deformation

Tensile deformation involves putting a load on a wire to stretch it. The easiest way to stretch it is to fix the wire securely near the ceiling, let it hang down and place weights on the free end. The extension is not likely to be great, but you can make sure that it is as large as possible by choosing a wire which is both long and thin. Even so you will need something more precise than a metre ruler to measure how far it extends when you load it.

A vernier scale is one way to do it, and Figure 8.2 shows how you might arrange it. The complete apparatus reaches from the ceiling almost to the floor.

Set up the apparatus as shown: use around 2 m of copper wire. It is essential that the clamp near the ceiling is absolutely secure – because the extension is so small, a slip of only a millimetre would completely invalidate the readings. The length marked L represents the length of wire being tested, so the vernier scale should be near its lower end.

Notice that the reference scale is attached to a similar wire, suspended from the same clamp. If the support at the top sags due to the heavy load being placed on it, both scales will descend by the same amount so it does not matter. Also, though less likely to be a problem, if the room warmed up considerably during the course of the experiment, both wires would have the same expansion so again the vernier reading would not be affected.

Increase the load by 0.5 kg at a time. Each time take the reading of the vernier scale and subtract it from its reading at the start to find the extension.

Record readings of the values of extension and applied load. Draw a graph with extension on the vertical axis and applied load on the horizontal axis. Write a report of your experiment. Use the writing frame in Section 1.4, pages 19–20.

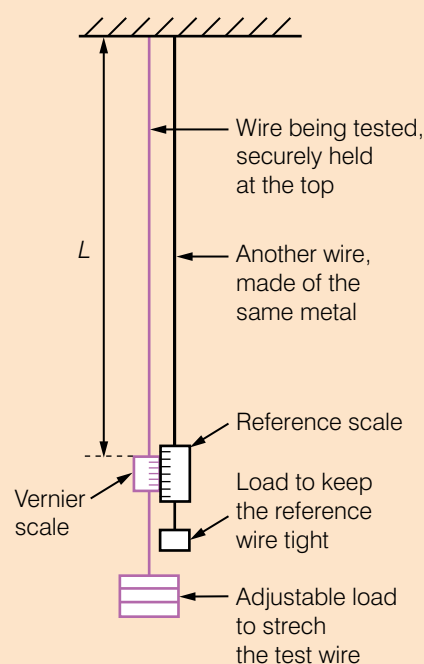

Figure 8.2 Vernier scale

a copper wire of 10 m length to extend by 1 mm is a far different outcome from causing a 10 cm wire to extend by that amount. Therefore we measure the deformation by the **tensile strain**, which is the extension, x , divided by the wire's original length, L .

$$\text{Tensile strain} = \frac{x}{L}$$

The tensile strain is just a number with no units. In effect it is the fractional extension of the wire. To calculate it, the extension and the length must, of course, both be expressed in the same units – usually metres.

Hooke's law

A graph of the extension plotted against the applied load in Activity 8.2 (see Figure 8.3) shows the sort of results that may be obtained for the copper wire.

The graph starts as a straight line. Over this range the extension will be proportional to the applied force – this is known as **Hooke's law**.

As the load increases, the line begins to curve. This point is marked A on the graph, and is known as the **limit of proportionality**.

At B, the **yield point** is reached, where there is a sudden increase in the extension. At C, the wire breaks.

Elastic limit

For small loads the extension is elastic, but for large loads the copper suffers plastic deformation. In Activity 8.2, you cannot know the exact load for which elastic behaviour ceases (we call it the elastic limit) – the only way of telling that is to remove the load each time and see if the wire recovers fully.

Nevertheless, you can be sure that over the Hooke's law region the behaviour is elastic. When the yield point is reached, it may be assumed that layers of atoms have slipped over one another within the metal and the wire will suffer a permanent extension. The graph does not indicate just where the elastic limit lies, but it is bound to be after A and near B.

The final part of the graph shows the copper deforming in a plastic manner, with ever increasing extensions until the wire breaks at point C.

Activity 8.3: Finding the elastic limit

Use the same apparatus as in Activity 8.2. Add a load until the extension starts to increase dramatically. Record the load required to reach this point – this will be the elastic limit of the wire.

Worked example 8.2

Find the tensile strain when a wire of length 2 m is extended by 5 cm.

Tensile strain	Extension (m)	Original length (m)
?	0.05	2

$$\begin{aligned} \text{Use tensile strain} &= \frac{0.05}{2} \\ &= 0.025 \end{aligned}$$

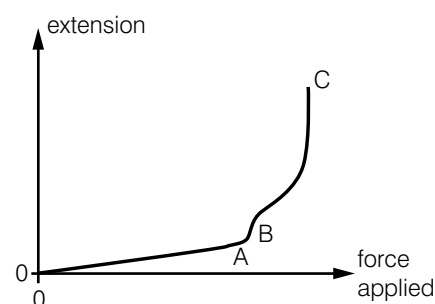

Figure 8.3 Hooke's law

KEY WORDS

tensile strain *extension x divided by the wire's original length, L*

$$\text{tensile strain} = \frac{x}{L}$$

Hooke's law *the force applied to a material is directly proportional to its extension, up to the elastic limit*

limit of proportionality *point at which extension and applied force are no longer proportional*

yield point *point where there is a sudden increase in extension*

Ductile materials and brittle materials

Because copper has a large plastic stage it is not difficult to deform it by drawing it out into a wire. Such material is described as being ductile.

At the other extreme there are some materials that have no plastic stage at all. These are described as being brittle.

If you stretch a glass fibre, for example, the extension–force graph would look like the one in Figure 8.4.

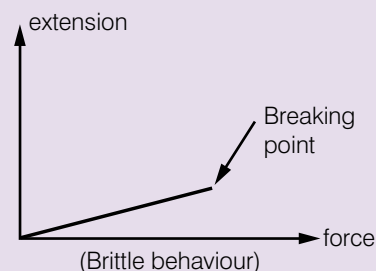

Figure 8.4 Brittle materials

The behaviour remains elastic all the way up to the breaking point, when it suddenly and unexpectedly snaps.

Not all metals are ductile. Cast iron is brittle, for instance. So too is tungsten – the metal used to make the filament in a light bulb – because of its extremely high melting point. The only way of making the filament is to take some of the powdered metal and compress it into the required shape.

KEY WORDS

Young's modulus *the ratio of tensile stress to tensile strain up to the material's limit of proportionality*

Young's modulus

We know that stress applied to a copper wire produces strain in it. For a measure of how readily copper stretches, we take the ratio tensile stress divided by tensile strain – the stress we would have to apply for each unit strain caused. This is **Young's modulus**, y , of the material, sometimes called the Young modulus and named after an English physicist.

The ratio will be a constant only over the straight line part of the extension–force graph, so Young's modulus describes behaviour over the range for which Hooke's law applies.

Therefore, Young's modulus is defined as:

the ratio of tensile stress to tensile strain up to the material's limit of proportionality.

In symbols:

$$E = \frac{\frac{F}{A}}{\frac{x}{L}}$$

Rearranging, this gives $E = \frac{FL}{xA}$.

The units of Young's modulus will be those of stress (N/m^2) divided by those of strain. Strain is just a number, so Young's modulus will be measured in N/m^2 .

This unit does have a name – the pascal (Pa), used especially for pressures. Sometimes Young's modulus will be expressed in Pa, but remember that is just N/m^2 by another name.

Worked example 8.3

A steel wire of length 3.0 m has a cross-sectional area of 4.1 mm². It hangs from a tall support, and a load of 500 g is attached to its end. By how much will it extend? Take Young's modulus of steel to be 2.0×10^{11} Pa.

Here F = the weight of the 500 g load, which is $0.5 \text{ kg} \times 9.8 \text{ N/kg} = 4.9 \text{ N}$

$$L = 3.0 \text{ m}$$

$$A = 4.1 \text{ mm}^2 = 4.1 \times 10^{-6} \text{ m}^2$$

(If you are not confident about doing this conversion, do not just ignore it. Be sure to ask your teacher for help.)

$$E = 2.0 \times 10^{11} \text{ Pa (that is, N m}^{-2}\text{)}$$

Starting with $E = \frac{FL}{xA}$ and rearranging, we get

$$x = \frac{FL}{EA}$$

Putting in the values, x

$$= \frac{4.9 \times 3.0}{2.0 \times 10^{11} \times 4.1 \times 10^{-6}} = \frac{14.7}{820000} = 1.79 \times 10^{-5} \text{ m}$$

E (N/m ²)	F (N)	L (m)	x (m)	A (m ²)
2×10^{11}	4.9	3.0	?	4.1×10^{-6}

Activity 8.4: Measuring Young's modulus

You can use the apparatus from Activity 8.2 here. The one difference is that you need to investigate only the elastic part of the graph this time.

Add loads one at a time, and for each one record from the vernier scale the extension x it has produced. If the loads are standard masses m , you can work out the force they cause by mg .

You must record the original length L of the wire. A metre ruler is sufficiently accurate for finding this.

You also require the cross-sectional area A of the wire. Measure the wire's average diameter d with a micrometer screw gauge at a few different points along the wire (including

some at right angles to others), divide it by 2 to get the wire's radius r , then use $A = \pi r^2$.

Because Young's modulus $E = \frac{FL}{xA}$

just one set of readings would suffice to give a value.

However, it is better to plot a graph of x against F and draw a best straight line through your readings. The gradient of the line is $\frac{x}{F}$, so 1 over the gradient gives your best estimate of $\frac{F}{x}$ obtained from all your readings. Multiply that by $\frac{L}{A}$ and you have Young's modulus.

KEY WORDS

bulk modulus *a measure of the ability of a substance to resist changes in volume when under increasing pressure from all sides*

shear modulus *a measure of the ability of a substance to resist deformation caused by a force parallel to one of its surfaces*

shear stress *the force divided by the cross-sectional area which is being sheared*

shear strain $\frac{\Delta x}{L}$ (see Figure 8.1)

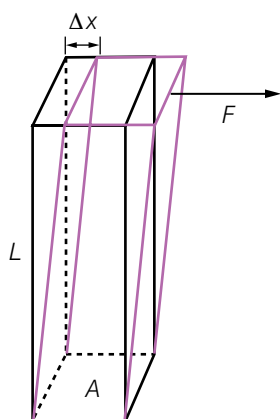

Figure 8.5 Bar under shear force

Bulk modulus and shear modulus

Each sort of deformation will have its own modulus of elasticity, and each one is defined as the ratio of stress over strain in the Hooke's law region – how much deforming stress is required to cause unit strain. All have the units N m^{-2} .

The difference lies in how each one defines the applied stress and the resulting strain.

The **bulk modulus** relates to a gas or a liquid which is subjected to an increased pressure acting on it. The pressure in N m^{-2} is the stress in this case. The deformation is a reduction in its volume as the substance gets squashed, so the strain is taken to be the ratio

$$\frac{\text{change in volume}}{\text{original volume}}$$

This corresponds exactly to the strain in a tensile deformation being taken as

$$\frac{\text{extension}}{\text{original length}}$$

Shear will occur if the base of the body is fixed and the deforming force causes it to tilt out of shape as shown in Figure 8.5.

The **shear modulus** is $\frac{\text{the shear stress}}{\text{the shear strain}}$

Shear stress is defined to be the force divided by the cross-sectional area which is being sheared ($\frac{F}{A}$), and the **shear strain** is $\frac{\Delta x}{L}$.

Strain energy

If you stretch a wire, you have to exert a force and move a distance. You have done work, and the chemical energy from your food has thereby been converted into strain energy in the wire.

Suppose you are exerting a force F on the wire, and this has caused it to extend by a distance x . You reached this situation by taking the unstretched wire and providing a steadily increasing force as it extended further and further, until by the end your force had risen to F .

Your force was not a constant one as you moved through the distance x . It built up steadily from 0 to F , so its average value was $\frac{1}{2} F$ – half way between the two extremes. The work you did may be calculated by that average force multiplied by the distance you moved it through, so it will be $\frac{1}{2} F x$.

Strain energy in a stretched wire = $\frac{1}{2} F x$

Worked example 8.4

Consider a long steel wire where a tension of 4.9 N causes an extension of 18 mm. Find the strain energy.

F (N)	x (m)
4.9	18×10^{-3}

The strain energy in it = $\frac{1}{2}Fx = \frac{1}{2} \times 4.9 \text{ N} \times 1.8 \times 10^{-3} \text{ m}$
 $= 4.4 \times 10^{-2} \text{ J}.$

Notice how small it is – only 44 millijoules (mJ). The large forces that have to be exerted are more than offset by the tiny distances moved.

Summary

In this section you have learnt that:

- The elastic limit is the point beyond which all materials are permanently deformed.
- Tensile stress is tensile force divided by cross-sectional area A of the wire.
- Tensile strain is the extension x divided by the wire's original length, L .
- Shear stress is the force divided by the cross-sectional area being sheared.
- Shear strain = $\frac{\Delta x}{L}$
- Young's modulus is the ratio of tensile stress to tensile strain over the range for which Hooke's law applies.
- Hooke's law states that the extension is proportional to the applied force.
- Shear modulus is shear stress ($\frac{F}{A}$) divided by shear strain ($\frac{\Delta x}{L}$).
- The energy stored in a stretched wire is $\frac{1}{2}Fx$ where F is the force applied and x is the extension.

Review questions

1. Define the terms a) elastic limit, b) stress, c) strain, d) Young's modulus, e) shear modulus.
2. A load of 2.0 kg is applied to the ends of a wire 4.0 m long, and produces an extension of 0.24 mm. If the diameter of the wire is 2.0 mm, find:
 - a) the stress on the wire
 - b) the strain it produces

- c) the value of Young's modulus of the material from which it is made
 d) the strain energy.
3. a) What load in kilograms must be hung from a steel wire 6.0 m long and radius 0.80 mm to produce an extension of 1.0 mm? Young's modulus for steel is 2.0×10^{11} Pa.
 b) What is the strain energy?

8.2 Fluid statics

By the end of this section you should be able to:

- Define the terms density, atmospheric pressure, absolute pressure, pressure, volume.
- Describe the concepts related to hydraulic and pneumatic systems.
- State and apply Archimedes's principle.
- Define surface tension and surface energy.
- Define the angle of contact and account for the shapes of the surfaces of liquids.
- Determine the relationship for capillary rise and use it to solve problems.

KEY WORDS

atmospheric pressure *the pressure exerted by weight of air against a surface*

density *the mass per unit volume of a substance*

pressure *the amount of force acting per unit area*

volume *the amount of space filled by an object or substance*

absolute pressure *the actual pressure at a given point*

Pressure due to a fluid column

The **pressure** (the force per unit area) at any point in a liquid depends on the depth and **density** (mass per unit **volume**) of the liquid. For example, the pressure at a depth of 10 m under the sea will be greater than the pressure at a depth of 5 m under the sea. This is why divers have to be particularly careful when they return to the surface, otherwise they can suffer from the effects of the pressure difference in the form of 'bends'. When we are on the surface of the earth, going about everyday business, we are subject to **atmospheric pressure**. This is the pressure exerted by the air around us and varies a little according to atmospheric conditions. Atmospheric pressure is used by weather forecasters to predict weather changes and is measured using an instrument called a barometer.

Pressure gauges measure pressure relative to atmospheric pressure but **absolute pressure** is defined as force applied perpendicular to a particular area.

Consider Figure 8.6.

At depth h in the liquid, the pressure is force per unit area at that point. If we look at a horizontal area A at depth h , then

$$\text{pressure} = \frac{\text{weight of liquid of volume } (A \times h)}{\text{area}}$$

If the liquid has density ρ , then since density = $\frac{\text{mass}}{\text{volume}}$

$$\text{mass } (m) = \text{volume} \times \text{density} = Ah\rho$$

$$\text{and weight of liquid} = mg = Ah\rho g$$

$$\text{So pressure } p = \frac{\text{weight}}{A} = Ah\rho g/A = h\rho g$$

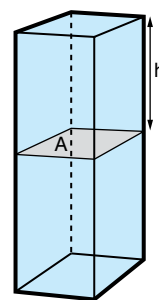

Figure 8.6 At depth h , the pressure is force per unit area at that point

Activity 8.5: Demonstrating the transmission of pressure by fluids (Cartesian diver)

Take a small test tube, partially filled with water, and cover the open end with part of a balloon, securely fastened with a rubber band, as shown in Figure 8.7.

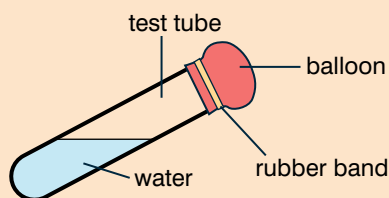

Figure 8.7 How to prepare the apparatus

Place the tube in a clear plastic squeeze bottle that is completely filled with water. Cap the squeeze bottle securely, squeeze it and observe what happens. (You may have to

experiment with the amount of water in the tube that is needed to produce this dramatic effect.)

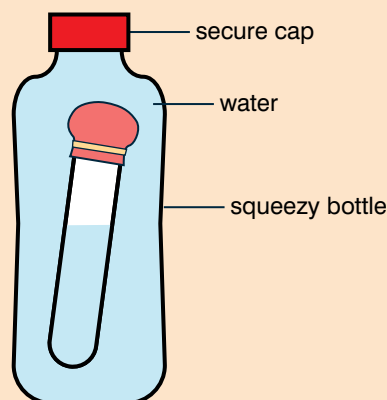

Figure 8.8 The Cartesian diver apparatus

Pascal's law and its applications

Activity 8.5 shows that fluids transmit pressure equally and are less compressible than gases. Pascal's law states that:

Pressure exerted anywhere in a confined liquid is transmitted equally and undiminished in all directions throughout the liquid.

The transmission of pressure in liquids is used in hydraulic brakes for vehicles. In this case the liquid is oil and it connects the master piston (which is operated by the brake pedal) to the slave piston, which is connected to the brake drums on the wheels of the car as shown in Figure 8.9.

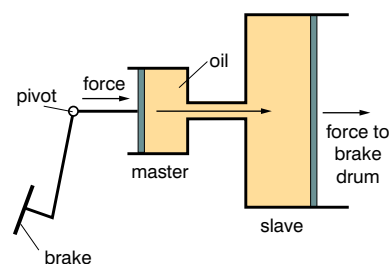

Figure 8.9 Oil connects the master piston to the slave piston and transmits the pressure on the brake to the brake drum

KEY WORDS

Pascal's law the pressure applied to an enclosed fluid is transmitted to every part of the fluid without reducing in value

Activity 8.6: What happens to water when it is under pressure?

This activity allows you to see what happens to the flow of water when it is under pressure. You will need two empty cans, nails and adhesive tape.

- Punch three holes horizontally at the bottom of one can, about 1.5 cm to 2 cm apart. Cover the holes with adhesive tape. What do you think will happen when you fill the can with water and remove the tape? Will any of the streams be longer than the others?
- Punch three holes diagonally in the side of another can. Cover the holes with adhesive tape. What do you think will happen when you fill the can with water and remove the tape? Will any of the streams be longer than the others?
- Fill both cans with water, and then tear off the tape on the can with the horizontal holes. Observe what happens.
- Now tear off the tape on the can with the diagonal holes. Observe what happens. Discuss your results with other students and try and explain them using Pascal's law.

Worked example 8.5

The force on a brake pedal is 2 N. The cross-sectional area of the pedal is 0.05 m². If the area of the brake drum is 0.045 m², what is the force on the brake drum?

F_{bp} (N)	A_{bp} (m ²)	F_{bd} (N)	A_{bd} (m ²)
2	0.05	?	0.045

$$\text{Use } \frac{F_{bp}}{A_{bp}} = \frac{F_{bd}}{A_{bd}}$$

$$\begin{aligned} \text{Rearrange } F_{bd} &= \frac{F_{bp}}{A_{bp}} \times A_{bd} \\ &= \frac{2}{0.05} \times 0.045 \\ &= 1.8 \text{ N} \end{aligned}$$

Activity 8.7: Other applications of hydraulics

In a small group, research other applications of hydraulics. (You could also research applications of pneumatics, which is where air is used as the medium for transmission of pressure rather than a liquid.) Present your findings to the rest of your class in a form of your choice.

Archimedes's principle and its applications

Archimedes's principle states that:

Any object, wholly or partially immersed in a fluid, is buoyed up by a force equal to the weight of the fluid displaced by the object.

The weight of the displaced fluid is directly proportional to the volume of the displaced fluid (if the surrounding fluid is of uniform density). Thus, among completely submerged objects with equal masses, objects with greater volume have greater buoyancy.

Buoyancy reduces the apparent weight of objects that have sunk completely to the sea floor.

Suppose a rock's weight is measured as 10 N when suspended by a string in a vacuum. Suppose that when the rock is lowered by the string into water, it displaces water of weight 3 N. The force it then exerts on the string from which it hangs would be 10 N minus the 3 N of buoyant force: $10 - 3 = 7$ N.

KEY WORDS

Archimedes's principle *the buoyant force on an object wholly or partially immersed in a fluid is equal to the weight of the fluid displaced by the object*

Activity 8.8: Finding the density of an object using Archimedes's principle

Use the relation $\text{density} = \frac{\text{mass}}{\text{volume}}$

to design a way of finding the density of an object by applying Archimedes's principle. Write a report on your method, explaining the steps and the theory behind them. Carry out your investigation on a selection of objects.

You learnt about equilibrium in Grade 10. A floating object is stable if it tends to restore itself to an equilibrium position after a small displacement. For example, floating objects will generally have vertical stability, as if the object is pushed down slightly, this will create a greater buoyant force, which, unbalanced against the weight force, will push the object back up.

Rotational stability is of great importance to floating vessels. Given a small angular displacement, which you learnt about in Grade 10, the vessel may return to its original position (stable), move away from its original position (unstable), or remain where it is (neutral). An object will be stable if an angular displacement moves the line of action of the forces acting on it to set up a 'righting moment'.

The atmosphere's density depends upon height above the surface of the earth (altitude). As an airship rises in the atmosphere, its buoyancy decreases as the density of the surrounding air decreases. As a submarine expels water from its buoyancy tanks (by pumping them full of air), it rises because its volume is constant (the volume of water it displaces if it is fully submerged) as its weight is decreased.

Submarines rise and dive by filling large tanks with seawater. To dive, the tanks are opened to allow air to exhaust out the top of the

DID YOU KNOW?

RMS Titanic sank in 1912 after it hit an iceberg. Before the collision, the average density of the ship was less than that of water but, after the collision left a hole in the structure, water poured in and the average density was then less than that of water and it sank.

Activity 8.9: Exploring Archimedes's principle

In a small group, design an investigation to explore Archimedes's principle. You could start by testing whether objects float or sink in water, and measuring the volume of water each displaces, then move on to making model boats in various shapes to test their stability. Record the steps in your investigation and the observations carefully, then try to explain them using Archimedes's principle.

tanks, while the water flows in from the bottom. Once the weight has been balanced so the overall density of the submarine is equal to the water around it, it has neutral buoyancy and will remain at that depth. Normally, precautions are taken to ensure that no air has been left in the tanks. If air were left in the tanks and the submarine were to descend even slightly, the increased pressure of the water would compress the remaining air in the tanks, reducing its volume. Since buoyancy is a function of volume, this would cause a decrease in buoyancy, and the submarine would continue to descend.

Worked example 8.6

The density of ice is 0.92 and the density of water is 1.00.

What percentage of an iceberg will be above sea level?

Since the iceberg is ice, and the relative density of ice is 0.92, the iceberg will 'sink' until it has displaced 0.92 of its volume. This means that 8% of the iceberg will be above sea level.

KEY WORDS

surface tension *a property of a liquid's surface that causes it to act like a stretched elastic skin; it is caused by the forces of attraction between the particles of the liquid and the other substances with which it comes into contact*

Surface tension and surface energy

Surface tension makes itself known when the surface of a liquid gives the appearance of being covered by a stretched elastic skin, which pulls small drops into a spherical shape.

There are two ways to reduce surface tension – warm the water, or add detergent to it.

Activity 8.10: Exploring the effects of surface tension

Try laying a needle very carefully on to the surface of some water, as shown in Figure 8.10. What happens?

Now dip a rectangular wire frame with a piece of cotton tied loosely across it in soap solution to produce a liquid film, as shown in Figure 8.11.

Burst the film one side and describe what happens.

Try to explain your observations in terms of the surface tension of water.

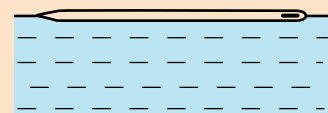

Figure 8.10 Effect of surface tension: steel needle on water surface

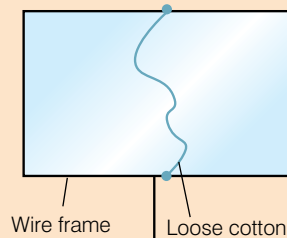

Figure 8.11 Effect of surface tension in a film of soap

The temptation is to think of the water as if it were being covered by a stretched rubber skin, but this does not fit everything that can be observed. With a rubber film, if the surface is stretched more, the tension will increase. With water, if the surface is stretched further, the tension stays exactly the same.

How can we explain this? What is the cause of surface tension?

Think of the liquid at a molecular level. For it to clump together and not split up into a gas, there must be forces of attraction between its molecules, which hold the liquid together. Figure 8.12 is an attempt to show these forces.

The molecules in the bulk of the liquid are surrounded by other molecules and so all the pulls cancel, but you can see that the ones at the surface seem to be tugged inwards. This disruption is measured by **surface energy**.

Figure 8.13 shows a very trivial sort of experiment and the outcome is exaggerated, but it is surprisingly revealing. A glass block is dipped into some water, and when you lift it up it comes out wet.

Stage 2 shows that you pull the water up with the block – as well as forces between neighbouring water molecules holding the water column together, there is also a cohesive force between the molecules in water and those in glass, so the water stays attached to the glass.

Stage 3 shows that the break, when it eventually occurs, happens within the water – the forces between glass and water are the stronger ones.

Surface tension is defined as:

a cohesive effect at the surface of the liquid due to the forces between the liquid's atoms or molecules.

$$f = \frac{F}{l} = \frac{\text{force}}{\text{length}}$$

Pressure difference across a surface film

In Activity 8.10, you will have observed that the surface of a liquid will tend to take on a curved shape. This observation tells us that there must be a pressure difference between the sides of the surface to cause the curvature. There is an equation which can be used to calculate the pressure difference called the Young–Laplace equation.

pressure difference = surface tension \times $\left(\frac{1}{R_1} + \frac{1}{R_2}\right)$, where R_1 and R_2

are the radii of curvature of each of the axes that are parallel to the surface.



Figure 8.14 The radii of curvature

In symbols $\Delta p = f \left(\frac{1}{R_1} + \frac{1}{R_2}\right)$, where p is pressure, f is surface tension.

If you solve this equation, you can find the shape of water drops, puddles, menisci, soap bubbles, and all other shapes determined by surface tension (such as the shape of the impressions that a water strider's feet make on the surface of a pond).

KEY WORDS

surface energy a measure of the disruption of intermolecular bonds caused by a surface

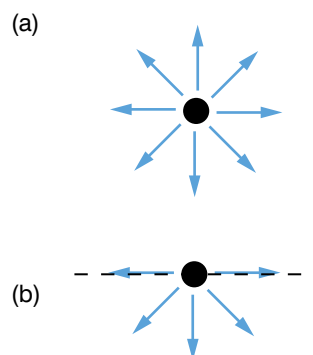

Figure 8.12 The forces on a molecule (a) in the bulk of a liquid and (b) at the surface

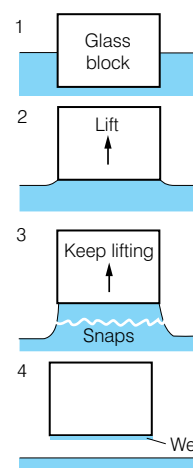

Figure 8.13 The effect of surface tension on a glass block lifted out of water



Figure 8.15 Water strider

KEY WORDS

contact angle *the angle at which a liquid surface meets a solid surface*

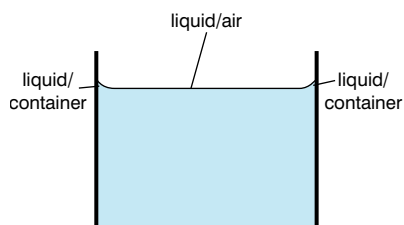

Figure 8.16 Interfaces between a liquid, its container and air

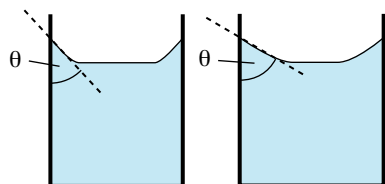

Figure 8.17 Examples of contact angles

Activity 8.11: Applications of surface tension ideas

In a small group, use the information given on pages 170–171 and your own research to write a presentation on the applications of surface tension ideas. Present your findings to the rest of your class.

Angle of contact and capillary action

No liquid can exist in a perfect vacuum for very long, so the surface of any liquid is an interface between that liquid and some other medium. For example, the top surface of a puddle is an interface between the water in the puddle and the air. This means that surface tension is not just a property of the liquid, but a property of the liquid's interface with another medium. If a liquid is in a container, then besides the liquid/air interface at its top surface, there is also an interface between the liquid and the walls of the container (see Figure 8.16).

Usually, the surface tension between the liquid and air is greater than its surface tension with the walls of a container. Where the two surfaces meet, their geometry must be such that all forces balance.

Where the two surfaces meet, they form a **contact angle**, which is the angle the tangent to the surface makes with the solid surface. Figure 8.17 shows two examples.

The contact angle for various liquid/solid interfaces has been measured and Table 8.1 shows these results.

Table 8.1 Contact angles for different liquid/solid interfaces

Liquid	Solid	Contact angle
water	soda-lime glass lead glass fused quartz	0°
ethanol		
diethyl ether		
carbon tetrachloride		
glycerol		
acetic acid		
water	paraffin wax	107°
	silver	90°
methyl iodide	soda-lime glass	29°
	lead glass	30°
	fused quartz	33°
mercury	soda-lime glass	140°

Where a water surface meets the glass wall of its container, the glass pulls some of the water molecules to it and a **meniscus** forms (see Figure 8.18). The forces are sufficiently strong to pull a column of water some distance up a narrow tube, until eventually the weight of the water prevents it from being pulled further – this is capillary action.

Capillary action explains two phenomena:

1. the movement of liquids in thin tubes
2. the flow of liquids through porous materials, such as the flow of water through soil.

Activity 8.12: Demonstrating capillary action in thin tubes

The movement of liquids through tubes can be demonstrated using a capillary tube (a glass tube with a narrow diameter).

Place the end of a capillary tube in a liquid such as water.

Describe what you see. Now use a tube with a wider diameter. Describe the differences in the results. Try to explain your observation in terms of surface tension before reading on.

KEY WORDS

capillary action the movement of a liquid along the surface of a solid caused by the attraction of molecules of the liquid to molecules of the solid

meniscus a curve in the surface of a liquid caused by the relative attraction of the liquid molecules to the solid surfaces of the container

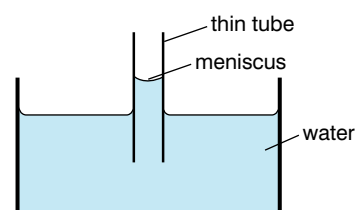

Figure 8.18 Capillary action

Explaining capillary action in thin tubes

Surface tension pulls the liquid column up until there is a sufficient mass of liquid for gravitational forces to overcome the intermolecular forces. The contact length (around the edge) between the top of the liquid column and the tube is proportional to the diameter of the tube, while the weight of the liquid column is proportional to the square of the tube's diameter, so a narrow tube will draw a liquid column higher than a wide tube. Different liquids will also have different capillary action, as shown in Figure 8.19, which compares the capillary action of water with the capillary action of mercury.

You can use this equation to find the height h of a liquid column

caused as a result of capillary action $h = \frac{2f \cos \theta}{\rho g \times r}$ where:

- f is the liquid–air surface tension
- θ is the contact angle
- ρ is the density of liquid
- g is acceleration due to gravity
- r is radius of tube (length).

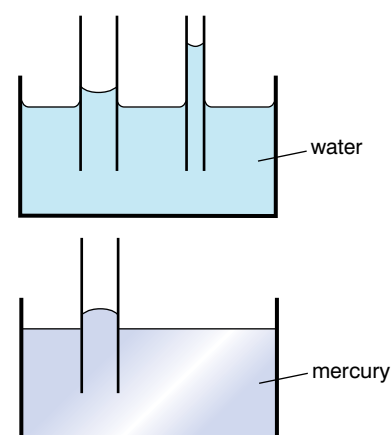

Figure 8.19 Comparing the capillary action of water with that of mercury

Activity 8.13: Exploring capillary action

Work in a small group. Moisten the lips of two styrofoam cups with water and press the cups firmly against opposite sides of a partially inflated balloon. Inflate the balloon further. What happens? Try to explain your observation in your small group.

Activity 8.14: Exploring applications of capillary action

Research some applications of capillary action. Present your findings to your class in a form of your own choice.

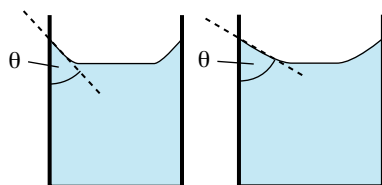

Figure 8.20 Contact angles

Worked example 8.7

Find the height of a column of methyl iodide in a soda–lime glass tube of radius 10 mm. The surface tension is 0.26, the contact angle is 29° , the density is 2.28.

h (m)	f	θ ($^\circ$)	ρ (kg/m^3)	g (m/s^2)	r (m)
?	0.26	29	2.28	9.81	10×10^{-3}

$$\text{Use } h = \frac{2 f \cos \theta}{\rho g r}$$

$$= \frac{2 \times 0.26 \times \cos 29}{(2.28 \times 9.81 \times 10 \times 10^{-3})} = 0.455 / 0.224 = 2 \text{ m}$$

Summary

In this section you have learnt that:

- Density = $\frac{\text{mass}}{\text{volume}}$
- Volume = length \times breadth \times height
- Pressure = $\frac{\text{force}}{\text{perpendicular area}}$
- Atmospheric pressure is the pressure exerted by the air around us.
- Absolute pressure is the force applied perpendicular to a particular area.
- Hydraulic and pneumatic systems rely on Pascal's law: pressure exerted anywhere in a confined liquid is transmitted equally and undiminished in all directions throughout the liquid.
- Liquid (or air) is used in hydraulic (or pneumatic) systems to transmit pressure from one place (such as a brake pedal) to another (such as a brake drum).
- Archimedes's principle states that any object, wholly or partly immersed in a fluid, is buoyed up by a force equal to the weight of the fluid displaced by the object.
- Surface tension is defined as a cohesive effect at the surface of the liquid due to the forces between the liquid atoms or molecules $f = \frac{F}{l} = \frac{\text{force}}{\text{length}}$
- Surface energy measures the disruption to the forces between the molecules at the surface of the liquid, which seem to be tugged inwards.
- The contact angle is the angle the tangent to the surface makes with the solid surface, as shown in Figure 8.20.
- For capillary rise, $h = \frac{2 f \cos \theta}{\rho g r}$

Review questions

1. Define the terms a) density, b) atmospheric pressure, c) absolute pressure, d) pressure, e) volume.
2. a) State Archimedes's principle.
b) Explain some applications of Archimedes's principle.
3. Define a) surface tension and b) surface energy.
4. a) Define the angle of contact.
b) Use the angle of contact to account for the shapes of the surfaces of liquids.
5. State the relationship for capillary rise.

8.3 Fluid dynamics

By the end of this section you should be able to:

- Define the terms laminar and turbulent flow, flow rate.
- Identify factors affecting and give examples of laminar flow.
- Identify factors that affect the streamlining of cars, boats and planes.
- Define the Reynolds number.
- State Bernoulli's principle.
- Explain applications of Bernoulli's principle.
- Use Bernoulli's equation to solve problems.
- State Stoke's law and use it to solve problems.
- Use equation of continuity to solve problems.

Streamline and turbulent flow

When a liquid flows in parallel layers, with no disruption between the layers as shown in Figure 8.21, the flow is known as **streamline** or **laminar** flow.

In this type of flow, air moves with the same speed in the same direction at all times and the flow appears to be smooth and regular. **Bernoulli's principle**, which states that a fluid (such as air) travelling over the surface of an object exerts less pressure than if the fluid were still, applies during laminar flow. Aeroplanes fly because of Bernoulli's principle. When an aeroplane takes off, air rushes over the top surface of its wing, reducing pressure on the upper surface of the wing. Normal pressure below the wing pushes the wing upward, carrying the airplane upward along with it. You will explore this principle in more detail on page 179.

In contrast, in **turbulent flow** there is disruption between the layers of fluid as shown in Figure 8.22.

KEY WORDS

Bernoulli's principle

principle stating that as the velocity of a fluid increases, the pressure exerted by that fluid decreases

streamline/laminar flow

type of fluid flow where the fluid travels smoothly in regular layers; the velocity and pressure remain constant at every point in the fluid

turbulent flow

type of fluid flow where there is disruption to the layers of fluid; the speed of the fluid at any point is continuously changing both in magnitude and direction

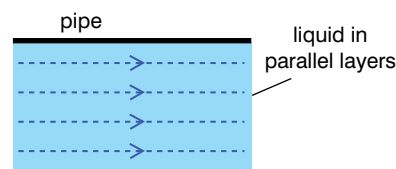

Figure 8.21 Streamline flow

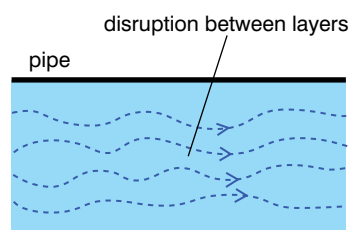

Figure 8.22 Turbulent flow

KEY WORDS

flow rate *the volume of liquid flowing past a given point per unit time*

This type of flow is chaotic and unpredictable. It consists of irregular eddies (circular currents) of air that push on a surface in unexpected ways. You may have experienced turbulence on a commercial aeroplane flight – your bumpy ride could have resulted from the development of turbulent flow over the aeroplane’s wings.

The **flow rate** is the volume of liquid flowing past a given point per unit time.

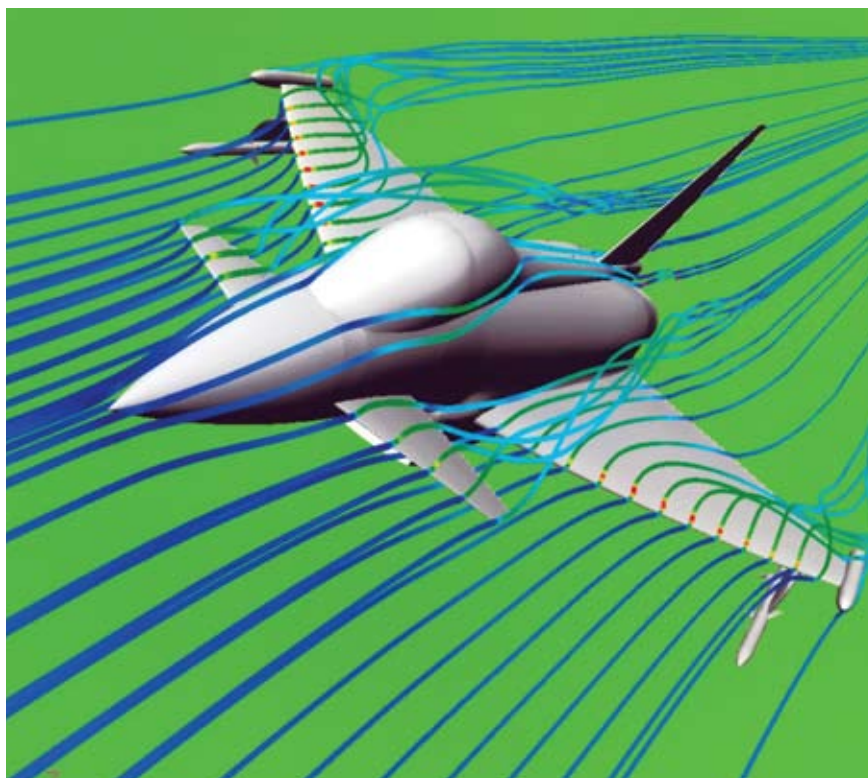

Figure 8.23 Turbulent flow over an aeroplane’s wings

Factors affecting laminar flow

There are four properties of air that affect the way it flows past an object: density, compressibility (how much its volume can be reduced), temperature and viscosity. (You will learn more about viscosity on page 180–181.)

The density and compressibility of air are important factors at high speeds. As an object travels rapidly through air, it causes air to become compressed and more dense. As a result, other properties of air then change.

The effects of temperature change on air flow also become important at high speeds. A regular commercial airplane, after landing, will feel cool to the touch.

Factors affecting streamlining of cars, boats and planes

Unless you keep pushing an object, as it moves through the air it will slow down because of air resistance acting to oppose the motion, as shown in Figure 8.24.

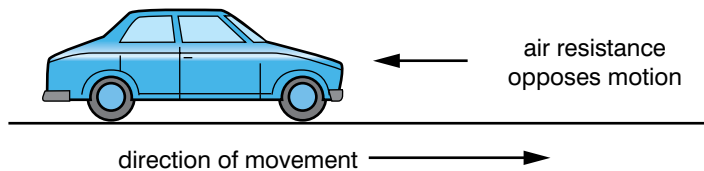

Figure 8.24 Air resistance opposes motion

In general, objects with larger surface areas will travel slower through the air (or any other fluid). There are certain shapes which help objects to speed up and travel faster through the air or other fluid than others – this is called streamlining. An application of streamlining is in motorsport, where the vehicles are designed so that their shape is streamlined to help their performance.

Activity 8.16: Exploring streamlining

Obtain a long see-through tube which you can fill with a liquid such as water. In a small group, make various objects out of modelling clay, some of which should have features which make them more streamlined than others (e.g. lower surface area at front, etc.). Drop the objects into the top of the tube of liquid and time how long they take to reach the bottom. Do the ones that you thought you had designed to be more streamlined travel more quickly through the liquid?

Equation of continuity

The **equation of continuity** in fluid dynamics states that the volume flow rate of an ideal fluid flowing through a closed system is the same at every point.

In Figure 8.26, the system is closed and so $V_{in} = V_{out}$, where V_{in} is the volume flow rate of liquid in, V_{out} is the volume flow rate of liquid out.

$$V_{in} = v_1$$

$$v_2 = V_{out}$$

where v_1 is the volume flow rate of section 1, v_2 is the volume flow rate of section 2.

$$\text{Since } V_{in} = V_{out}$$

$$v_1 = v_2$$

$$\text{Flow rate} = \frac{\text{volume}}{\text{time}}$$

Activity 8.15: Identifying streamlining features on motorsport vehicles

Compare the photographs of the ordinary car and Formula 1 car here. What differences can you see?



Figure 8.25 a) Typical Ethiopian car, b) Formula 1 car

KEY WORDS

equation of continuity the mass flow rate of fluid flowing into a system is equal to the mass flow rate of fluid leaving the system

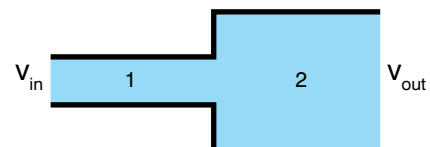

Figure 8.26 An ideal fluid flowing through a closed system

Worked example 8.8

Water flows at $10 \text{ m}^3/\text{h}$ through a pipe connected to a tap. At what rate will the water leave the tap?

Use the equation of continuity.

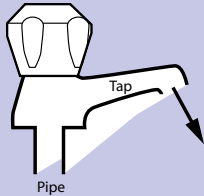

Figure 8.27

The volume flow rate is the same at every point.

Volume flow rate = volume flow rate of tap

$$10 \text{ m}^3/\text{h} = 10 \text{ m}^3/\text{h}$$

Water will leave the tap at $10 \text{ m}^3/\text{h}$

**Activity 8.17:
Application of the
equation of continuity**

You can demonstrate the equation of continuity by taking a hose, watching the water flow out and then half covering the exit point with your thumb. What happens to the speed of the water coming out of the hose? Try to explain the observation using the equation of continuity before reading on.

$$\theta = \frac{V_{in}}{\text{time}} = \frac{v_1}{\text{time}} = \frac{v_2}{\text{time}} = \frac{V_{out}}{\text{time}}$$

Since $V_{in} = v_1 = v_2 = V_{out}$ θ is the same at all points in the system.

$$m = \rho_{i1} v_{i1} A_{i1} + \rho_{i2} v_{i2} A_{i2} + \dots + \rho_{in} v_{in} A_{in} \\ = \rho_{o1} v_{o1} A_{o1} + \rho_{o2} v_{o2} A_{o2} + \dots + \rho_{om} v_{om} A_{om} \quad (1)$$

where

m = mass flow rate (kg/s)

ρ = density (kg/m^3)

v = speed (m/s)

A = area (m^2)

With uniform density, equation (1) can be modified to

$$q = v_{i1} A_{i1} + v_{i2} A_{i2} + \dots + v_{in} A_{in} \\ = v_{o1} A_{o1} + v_{o2} A_{o2} + \dots + v_{on} A_{on} \quad (2)$$

where

q = flow rate (m^3/s)

$$\rho_{i1} = \rho_{i2} = \dots = \rho_{in} = \rho_{o1} = \rho_{o2} = \dots = \rho_{on}$$

Worked example 8.9

Water flows at $10 \text{ m}^3/\text{h}$ through a pipe with 100 mm inside diameter. The pipe is reduced to an inside dimension of 80 mm. Find the velocity of the water in each part of the pipe.

Using equation (2)

$$q = v_{i1} A_{i1} + v_{i2} A_{i2} + \dots + v_{in} A_{in} \\ = v_{o1} A_{o1} + v_{o2} A_{o2} + \dots + v_{on} A_{on}$$

the velocity in the 100 mm pipe can be calculated as

$$(10 \text{ m}^3/\text{h})(1 / 3600 \text{ h/s}) = v_{100} (3.14 (0.1 \text{ m})^2 / 4)$$

or

$$v_{100} = (10 \text{ m}^3/\text{h})(1 / 3600 \text{ h/s}) / (3.14 (0.1 \text{ m})^2 / 4) \\ = 0.35 \text{ m/s}$$

Using equation (2), the velocity in the 80 mm pipe can be calculated

$$(10 \text{ m}^3/\text{h})(1 / 3600 \text{ h/s}) = v_{80} (3.14 (0.08 \text{ m})^2 / 4)$$

or

$$v_{80} = (10 \text{ m}^3/\text{h})(1 / 3600 \text{ h/s}) / (3.14 (0.08 \text{ m})^2 / 4) \\ = 0.55 \text{ m/s}$$

Common applications of the equation of continuity are pipes, tubes and ducts with flowing fluids or gases, rivers, overall processes as power plants, roads, computer networks and semiconductor technology.

Explaining the results of Activity 8.17

The rate of flow stays constant in a closed system. The decrease of the cross-section of the opening is balanced by the increased speed

of the water. Note that you cannot apply the equation to the water once it has left the system as it is no longer in a closed system!

Bernoulli's equation

We discussed Bernoulli's principle briefly on page 175. In most examples of liquid flow, we can consider that the fluid in the flow can be described as incompressible flow. Bernoulli performed his experiments on liquids and his equation in its original form is valid only for incompressible flow.

A common form of Bernoulli's equation, which is valid at any arbitrary point along a streamline where gravity is constant, is:

$$\frac{p}{\rho} + gh + \frac{v^2}{2} = \text{constant}$$

where:

- v is the fluid flow speed at a point on a streamline
- g is the acceleration due to gravity
- h is the elevation of the point above a reference plane, with the positive z -direction pointing upward — so in the direction opposite to the gravitational acceleration
- p is the pressure at the point
- ρ is the density of the fluid at all points in the fluid.

In many applications of Bernoulli's equation, we can use the following simplified form:

$$p + q = p_0$$

where p_0 is called total pressure, and q is dynamic pressure. The pressure p is often referred to as static pressure to distinguish it from total pressure p_0 and dynamic pressure q .

The simplified form of Bernoulli's equation can be summarised as:

$$\text{static pressure} + \text{dynamic pressure} = \text{total pressure}$$

Every point in a steadily flowing fluid, regardless of the fluid speed at that point, has its own unique static pressure p and dynamic pressure q . Their sum $p + q$ is defined to be the total pressure p_0 . The significance of Bernoulli's principle can now be summarised as:

Total pressure is constant along a streamline.

Activity 8.19: Demonstrating Bernoulli's principle 2

Suspend two light bulbs from a table rod in the field of an overhead projector turned on its side so that you can see the magnified image on the ceiling. Blow sharply between the bulbs so that they clank together.

As an alternative, you could blow sharply between two pieces of paper or ping-pong balls.

Activity 8.18: Demonstrating Bernoulli's principle 1

Take a ping-pong ball and a hairdryer. Use the flow of air from the hair-dryer to hold the ping-pong ball in the air. How long can you support the ball with the air flow? Try other light objects such as feathers and pieces of paper (take care not to put the heat source too close to them though!). Make a table of results to compare the mass of the object and how long it can be held up in the airflow.

Worked example 8.10

Use the simplified version of Bernoulli's equation to find the total pressure when the static pressure is 5 Pa and the dynamic pressure is 7 Pa.

static pressure + dynamic pressure = total pressure

$$5 \text{ Pa} + 7 \text{ Pa} = 12 \text{ Pa}$$

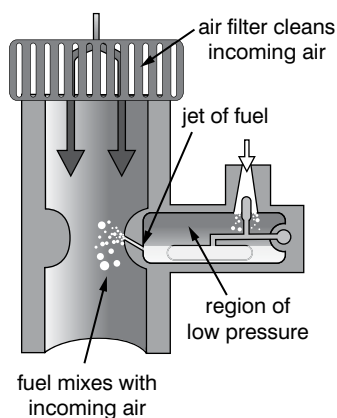

Figure 8.28 In the narrow throat, the air is moving at its fastest speed and is therefore at its lowest pressure



Figure 8.29 The wind passing in front of the sail is fast enough to experience a significant reduction in pressure and the sail is pulled forward

Further applications of Bernoulli's principle

We have already learnt (on page 175) that Bernoulli's principle can be used to calculate the lift force on an aeroplane if you know the behaviour of the fluid flow in the vicinity of the wing. Other applications of the principle include:

- The carburettor in engines contains a device to create a region of low pressure to draw fuel into the carburettor and mix it thoroughly with the incoming air. The low pressure in the device can be explained by Bernoulli's principle; in the narrow throat, the air is moving at its fastest speed and therefore it is at its lowest pressure.
- The pitot tube and static port on an aircraft are used to determine the airspeed of the aircraft. These two devices are connected to the airspeed indicator which determines the dynamic pressure of the airflow past the aircraft. Dynamic pressure is the difference between stagnation pressure and static pressure. Bernoulli's principle is used to calibrate the airspeed indicator so that it displays the indicated airspeed appropriate to the dynamic pressure.
- The flow speed of a fluid can be measured using a device placed into a pipeline to reduce the diameter of the flow. For a horizontal device, the continuity equation shows that for an incompressible fluid, the reduction in diameter will cause an increase in the fluid flow speed. Subsequently Bernoulli's principle then shows that there must be a decrease in the pressure in the reduced diameter region.
- The maximum possible drain rate for a tank with a hole or tap at the base can be calculated directly from Bernoulli's equation, and is found to be proportional to the square root of the height of the fluid in the tank.
- The principle also makes it possible for sail-powered craft to travel faster than the wind that propels them (if friction can be sufficiently reduced). If the wind passing in front of the sail is fast enough to experience a significant reduction in pressure, the sail is pulled forward, in addition to being pushed from behind. Although boats in water must contend with the friction of the water along the hull, ice sailing and land sailing vehicles can travel faster than the wind.

Viscosity

If water flows through a pipe, smooth streamline motion can ensue. The layer of water touching the walls is at rest, the water in the centre is moving fastest. The layers of water are travelling at an increasing speed as we go from the walls to the centre, and this means that each layer is being dragged forward by the faster layer one side but held back by the slower one on the other side. The overall outcome turns out to be a resultant drag force (Figure 8.30).

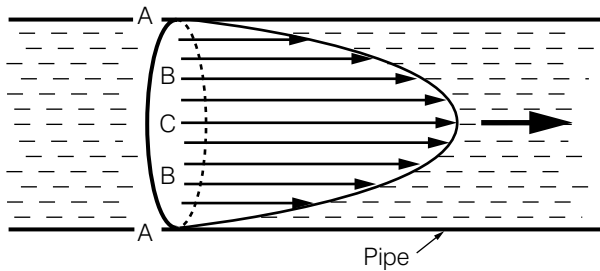

Figure 8.30 Velocity of layers of liquid in a pipe

The force required to drive the layers

$$F = \eta A \frac{\Delta v}{\Delta y}$$

where v = speed of flow

y = distance from container wall

A = cross-sectional area

η = viscosity

Some liquids flow more readily through pipes, or move out of the way more freely to allow a body to move through them. These are the liquids that have a low **viscosity** – to put it simply, they are very runny.

The coefficient of viscosity

Thick oils and the like are quite the opposite. They are very viscous, and large drag forces appear when layers have to slide over one another. The viscosity of a liquid may be measured by a quantity called its coefficient of viscosity, given the Greek letter η ('eta'). Its units are kg/m/s, and a large number indicates a viscous liquid. It is not essential that you remember those units – so long as you put all the values into an equation in their basic SI units it is bound to work out. As a liquid warms up, its viscosity falls considerably.

The viscous force between layers is determined in part by how rapidly the velocity is changing as you go from layer to layer. This is specified by what is known as the velocity gradient. It is the change in velocity (in m/s¹) per metre as you move in from the wall of the pipe. It is measured in m/s per metre, and m/s/m reduces to just /s.

The second factor is just the area of contact A between the two layers. In a given liquid at a given temperature, the viscous drag force F acting between the layers is given by

$$F = (\text{a constant}) \times A \times \text{the velocity gradient.}$$

The constant is defined to be the viscosity η of the liquid.

Stokes' law and terminal velocity

Consider a body moving through a fluid (or the fluid moving past the body, which is the same thing). The viscous drag force on the moving body (the 'head wind' effect) may be worked out. For simplicity we imagine the body is a sphere, of radius r .

Activity 8.20: Comparing viscosity of various liquids

In a small group, devise an investigation to find out which of a selection of liquids is the most viscous. You could compare water and cooking oil, for example. Think carefully about your method and check it with your teacher before you begin. How will you record your observations so that you can draw conclusions? What measurements will you need to take?

KEY WORDS

viscosity *the internal resistance of a fluid to flow and a measure of 'thickness' of a fluid*

Poiseuille's Law

Poiseuille's law states that

$$\text{Volume flowrate} = \frac{\pi \times \Delta p r^4}{8 \eta L}$$

Where Δp is the difference in pressure between the ends of a pipe

r is the radius of the pipe

η is the coefficient of viscosity

L is the length of the pipe

KEY WORDS

terminal velocity *the maximum constant velocity reached by a falling body when the drag force acting on it is equal to the force of gravity acting on it*

Activity 8.21: Measuring terminal velocities

If you have available a long transparent tube, you may be able to fill it full of a liquid and measure terminal speeds through it to find the liquid's viscosity at room temperature. Steel ball bearings through an oil may be suitable, perhaps.

The details, and the theory behind it, are up to you.

Start with just one ball. How will you measure its terminal velocity v ? What other quantities will you have to measure, and how? How could you take a check reading?

Worked example 8.11

Find the force on a ball bearing of radius 4×10^{-3} m falling through a liquid of viscosity 0.985 at a velocity of 0.5 m/s.

F (N)	η (kg/m/s ⁻¹⁵⁻¹)	r (M)	v (m/s)
?	0.985	4×10^{-3}	0.5

$$F = 6\pi\eta r v = 6\pi \times 0.985 \times 4 \times 10^{-3} \times 0.5 = 0.01182\pi \text{ N}$$

There are three factors that affect the magnitude of the drag force F :

1. There is the size of the body. A reasonable guess might be that what matters is the area which the shape presents to the fluid, but this turns out not to be the case. The force is proportional to the radius r .
2. The force is also proportional to the velocity v at which the sphere moves through the air: double that velocity and the drag force doubles.
3. The third factor is the viscosity of the fluid, which is η .

Put them all together and we get

$$F = (\text{some constant}) \times \eta \times r \times v.$$

A full theoretical treatment tells us that the constant is 6π , and the result is Stokes's law – the viscous drag force F that acts on a sphere of radius r travelling at a velocity v through a fluid of viscosity η is given by:

$$F = 6\pi\eta r v$$

If a ball is dropped through a fluid, the force of gravity causes it to go faster and faster. As its velocity increases, the drag force becomes bigger too. Eventually it is going so fast that the drag force is as large as its weight and therefore cancels it out. The ball no longer accelerates. Instead it goes at a constant velocity – its **terminal velocity** through that fluid.

If you have spheres that are similar except that they are of, say, five different sizes, how could you improve the method? Could you plot a graph of your results and deduce the viscosity from that?

Reynolds numbers

The Reynolds number, which does not have any units, is an important variable in equations that describe whether flow conditions lead to laminar or turbulent flow. In the case of flow through a straight pipe with a circular cross-section, Reynolds numbers of less than 2300 are generally considered to be of a laminar type. However, the Reynolds number at which laminar flows become turbulent is dependent upon the flow geometry.

Summary

In this section you have learnt that:

- Laminar flow occurs when liquids flow in parallel layers and there is no disruption between the layers.
- Turbulent flow occurs when there is disruption between the layer of fluid.
- The flow rate is the volume of liquid flowing past a given point per unit time.
- Factors that affect laminar flow are density, compressibility (how much the volume of the liquid can be reduced), temperature and viscosity.
- Density, compressibility and temperature of air become important at high speeds: on landing, a commercial aeroplane will feel cool to the touch.
- The Reynolds number is available in equations that describe whether conditions lead to laminar or turbulent flow.
- Bernoulli's principle states that a fluid travelling over the surface of an object exerts less pressure than if the fluid were still, for example, when aeroplanes fly.
- Bernoulli's equation is $\frac{p}{\rho} + gh + \frac{v^2}{2} = \text{constant}$.
- A simplified form is
static pressure + dynamic pressure = constant
- Stoke's law is
the viscous drag force F that acts on a sphere of radius r travelling at a velocity v through a fluid of viscosity η is given by $F = 6\pi\eta r v$.
- The equation of continuity states that the volume flow rate of an ideal fluid flowing through a closed system is the same at every point.

Review questions

1. Give examples of laminar flow.
2. Identify factors that affect the streamlining of cars, boats and planes.
3. Define the Reynolds number.
4. State Bernoulli's principle.
5. Use the simplified version of Bernoulli's equation to find the total pressure when the static pressure is 9 Pa and the dynamic pressure is 3 Pa.
6. State Stokes's law.
7. State the equation of continuity.

8.4 Heat, temperature and thermal expansion

By the end of this section you should be able to:

- Define the terms calorimetry, phase, phase change, phase diagram, state variable, critical point, triple point, latent heat, heat capacity, specific heat capacity.
- Distinguish between heat, temperature, internal energy and work.
- Describe the units for heat, heat capacity, specific heat capacity and latent heat.
- Explain the factors that determine the rate of heat flow through a material.
- Describe the thermal expansion of solids in terms of the molecular theory of matter.
- Carry out calculations involving expansivity.
- Solve problems involving thermal conductivity.
- Describe experiments to measure latent heat.

KEY WORDS

specific heat capacity *the heat energy required to raise the temperature of 1 kg of a given substance by 1 K*

heat capacity *the heat capacity, C , of a body of mass m is given by heat capacity + $m \times$ specific heat capacity*

Specific heat capacity

You learnt about **specific heat capacity** in Grade 9, Section 7.3, so this section should be revision.

Accurate measurements suggest that for every gram of water we are heating and for every 1 K we are raising its temperature, we have to supply about 4.2 J of energy. If we took a thousand times as much water, that is, a kilogram, we would have to provide a thousand times as much energy (4200 J) to raise the temperature of this larger mass of water by 1 K.

Other substances vary. Kerosene, for instance, is found to need only 2200 J of energy to warm 1 kg of it by 1 K. Thus a kettle containing a kilogram of kerosene instead of water would heat up nearly twice as fast, but as the heat escaped again it would cool down more quickly.

The **specific heat capacity** of a substance is defined as:

The number of joules of heat energy required to raise the temperature of 1 kg of it by 1 K.

(Sometimes the specific heat capacity is defined as the amount of energy needed to raise the temperature of 1 gram of a substance by 1 K, but the definition using 1 kg is more correct.)

Specific heat capacity is represented by the symbol c . If you had got not 1 kg but m kg to warm up, you would have to supply m times as much heat energy. Likewise if you raised its temperature through not 1 K but through a temperature rise of $\Delta\theta$, then $\Delta\theta$ times as many joules of energy are needed. (The symbol Δ is the capital form of the Greek letter delta, and should be understood as the difference in θ).

Therefore, to find the number of joules of energy needed:

1. Take the specific heat capacity c in J/kg/K or in J/g/K.
2. Multiply it by the number of kilograms (or grams) you are heating.
3. Multiply it again by the change in temperature in kelvin.

This process can be summed up by the formula: $E_H = mc \Delta\theta$

where E_H is the number of joules of energy to be supplied (if you are heating the substance), or the number of joules of thermal energy released (if it is cooling down).

Worked example 8.12

The specific heat capacity of water is 4200 J/kg/K. How much energy will be needed to warm 800 g of water from 17°C to 27°C?

E_H	m	c	$\Delta\theta$
J	kg	J kg ⁻¹	K ⁻¹
?	0.8	4200	10

The change in temperature $\Delta\theta = 27 - 17 = 10$ K

Because the specific heat capacity has been given in J/kg/K, we must take ' m ' to be not 800 g but 0.8 kg.

$$E_H = mc\Delta\theta = 0.8 \times 4200 \times 10 = 33\,600 \text{ J}$$

Notice carefully in the above example that a rise in temperature from 17°C to 27°C is a gain of 10 K. Degrees Celsius and the kelvin are the same-sized interval of temperature. You do not need to add 273 to the 17°C and 27°C; you would still end up with a 10 degree rise in temperature.

Worked example 8.13

Using a current of 1.5 A, a 12 V, 1.5 A heater was used to heat 100g of water for 15 minutes. The temperature rose from 21°C to 52°C. Based on these results, how much energy would be required to warm 1 kg of water by 1°C?

Power of heater (W)	Energy supplied (J)	$\Delta\theta$ (°C)
$12 \times 1.5 = 18$	$15 \times 60 \times 18 = 16\,200$	$52 - 21 = 31$

Use $E = mc\Delta\theta$

$$\begin{aligned} c &= \frac{E}{m\Delta\theta} \\ &= \frac{16\,200}{0.1 \times 31} \\ &= \frac{16\,200}{3.1} \\ &= 5226 \text{ J/kg/K} \end{aligned}$$

Activity 8.22: Measuring the specific heat capacity of a liquid by electrical heating

To find the specific heat capacity of water you need to supply a measured number of joules of heat energy to a known number of kilograms of water, and see what temperature rise results.

If you use an electric heater submerged under the water (an immersion heater), you can measure accurately its wattage. You work out the power of the heater in watts by multiplying the voltage drop across the heating coil by the current in amperes which is passing through it ($P = VI$). This works because the voltage tells you how many joules of heat energy will be produced for each coulomb of charge that passes, and the current is the number of coulombs which pass every second.

All this energy goes into the water, so we simply have to insulate the water's container in order to keep it there. Figure 8.31 shows the electrical circuit. Do not switch on until the heater is covered by water or you may burn it out.

The rest of the apparatus is shown in Figure 8.32. A suitable container is an insulated cup of the sort drinks are sometimes sold in. The lid can be made

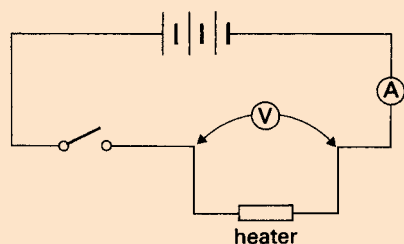

Figure 8.31 The circuit used to find the specific heat capacity of a liquid

from a small piece of plastic or hardboard. The thermometer can be supported by a tight-fitting collar cut from a length of rubber tubing. The stirrer must be made from a piece of insulated wire so that it does not short out the heater.

What we are trying to find out, remember, is how many joules of energy are needed to raise the temperature of 1 kg of water by 1°C. A kilogram is a lot of water to heat, however, so it makes sense to take 100 g and scale the final answer up. A convenient way to measure the water out is to pour 100 cm³ into the cup from a measuring cylinder, since the density of water is 1 g/cm³.

You are now ready to start. Record the temperature of the cold water, then start a stopwatch and switch on the heater.

A temperature rise of 1°C is too small to measure accurately, so aim for a temperature rise somewhere between 10 and 30°C. When you have finished, switch off, note the time, stir thoroughly and take the final temperature of the water.

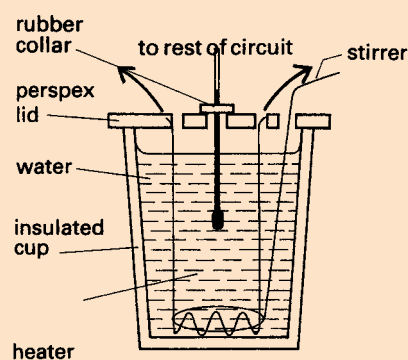

Figure 8.32 The rest of the apparatus used to find the specific heat capacity of a liquid

Sample readings

Use your own results if possible, but if not make use of these sample readings:

Mass of water being heated = 100 g

Starting temperature of cold water = 22°C

Steady current I through heater = 1.5 A

Steady p.d. V across heater = 12.0 V

Total time t of heating = 10 min = 600 s

Final temperature of warm water = 47°C

Analysing the readings

1. What is the power of the heater (in watts)?
2. How many joules of heat energy did the heater supply in total?
3. Through how many degrees C did this energy warm the 100 g of water?
4. How much energy, therefore, was needed to warm 1 kg of water by 1°C?

Calorimetry

Calorimetry is the science of measuring the heat of chemical reactions or physical changes. Calorimetry involves the use of a calorimeter. The word calorimetry is derived from the Latin word calor, meaning heat. Scottish physician and scientist Joseph Black, who was the first to recognise the distinction between heat and temperature, is said to be the founder of calorimetry.

Change of state

In Grade 9, you learnt about changes of state in Section 7.4. The three states of matter that you have considered are solid, liquid and gas. Each of these states of matter can be considered as a **phase**.

A **phase change** occurs when a substance changes state – for example, when ice (solid) turns to water (liquid) which then turns to vapour. These changes of state happen when the kinetic energy of the molecules in the substance increases (which we usually record as an increase in temperature, because the kinetic energy of the molecules in a substance, *internal energy*, is related to the temperature of the substance) or decreases (which we usually record as a decrease in temperature). A **phase change diagram** such as the one in Figure 8.33 shows the three phases of a substance.

The diagram shows the **triple point** for the substance, which is the point where all three states coexist together. This occurs at 0°C for water. At the **critical point** the liquid and gas phases become indistinguishable.

KEY WORDS

calorimetry *the experimental approach to measuring heat capacities and heat changes during chemical and physical processes*

critical point *the temperature and pressure at which the liquid and gas phases of a substance become identical*

phase *the distinct form of a substance under different conditions, e.g. solid, liquid, gas*

phase change *a change from one state of matter to another without a change in chemical composition*

phase change diagram *a graph of pressure against temperature which can be used to show the conditions under which each phase of a substance exists*

state variable *a variable that describes the state of a dynamic system. In thermodynamics, this may include properties such as temperature, pressure or internal energy*

triple point *the temperature and pressure at which the three phases of a substance coexist*

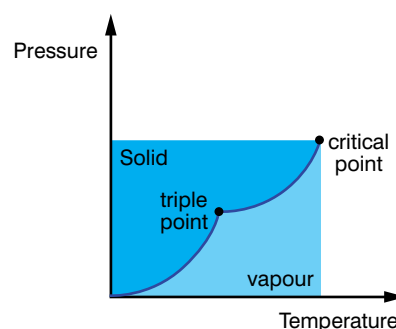

Figure 8.33 Phase change diagram

Activity 8.23: The phase diagram

In a small group, discuss the phase diagram in Figure 8.33 and try to explain what it shows in your own words.

KEY WORDS

latent heat *the amount of energy released or absorbed by a substance during a change of state that occurs without a change in temperature*

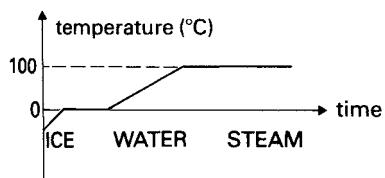

Figure 8.34 Why does the temperature stop rising at 0°C and 100°C?

Latent heat

If you heat a body, it will get hotter. That seems pretty obvious, so it may come as a surprise to discover that it is not necessarily true.

If you imagine being given a beaker containing water at 100°C and a Bunsen burner, you will begin to see why. You can continue to feed thermal energy into that water, but a thermometer would persist in reading 100°C. The extra energy you are supplying does not show itself as a rise in temperature, and it is given the name **latent heat**. ‘Latent’ means hidden.

The water of course is boiling away and turning to steam. The energy goes not into making the molecules move faster, but instead it is used to separate the molecules from each other. Work has to be done in moving them apart against the attractive forces which hold them together as a liquid.

Something similar happens as ice melts. All that time the heat energy it is gaining makes it no hotter, but instead it goes into breaking down the rigid structure of the solid.

Figure 8.34 shows what should happen if heat energy is fed into a block of ice in a steady and even way. Despite this constant input of heat energy the temperature twice stays fixed: once at 0°C as it melts and once at 100°C as it boils.

Melting and boiling are, of course, examples of changes of state, from the solid state to the liquid state or from liquid to gas. Whenever a substance changes state, latent heat is involved.

When steam condenses or water freezes, this latent heat is given out again. A scald from steam at 100°C can prove much worse than a scald from water at that temperature. The steam condenses on the cool skin, giving out its considerable latent heat as it turns to water still at 100°C, and then the hot water gives out its heat in turn as it cools down.

Activity 8.24: Determining the amount of heat necessary to convert a known quantity of ice at 0°C to water at 0°C

In a small group, use the experience you have gained from the activities so far in this section to devise and carry out an investigation into the amount of heat necessary to convert a known quantity of ice to water at 0°C. Show your plans to your teacher before you begin the investigation. How will you measure how much heat is supplied? What measurements will you need to take?

Specific latent heat of fusion

The process of melting is sometimes called fusion (which is how an electrical fuse got its name). Likewise changing from a liquid to a gas is called vapourisation, and includes evaporation as well as boiling.

To turn a 1 kg block of ice at 0°C into water still at 0°C needs about 340 000 J of energy (which may be expressed as 340 kilojoules, 340 kJ). It is a very large figure, partly because the joule is quite a small unit but mainly because it does take a lot of energy to melt 1 kg of ice.

The figure is referred to as the specific latent heat of fusion (symbol ' L_f ') of ice. The units are joules per kilogram (J/kg).

The specific latent heat of fusion of a substance is

the thermal energy required to change 1 kg of the solid at its melting point into 1 kg of liquid at the same temperature.

If you tried to melt not 1 kg but 2 kg of ice, you would have to supply twice as much energy (i.e., $2 \times 340\,000$ J).

In order to melt m kg of ice, the energy E_H needed is given by:

$$E_H = mL_f$$

Activity 8.25: Measuring the specific latent heat of fusion of ice

The question you want to answer here is: how many joules of heat energy are needed to change 1 g (or 1 kg) of ice at 0°C into water still at 0°C?

If ice cubes on the point of melting are added to a drink, then it becomes chilled. The heat energy removed from your drink has gone first into melting the ice and then into warming that 'molten ice' up from 0°C to the temperature of the rest of the chilled drink.

An experiment to discover how effective ice cubes are at cooling a drink should help us to find an answer to the question.

Figure 8.35 shows the idea. We assume the ice is at its melting point, but it is important to make sure the ice cubes are carefully dried with filter paper before they are added. It is therefore not feasible to weigh them before putting them in, so we find the number of grams of ice added by seeing at the end how much heavier the cup of water has become.

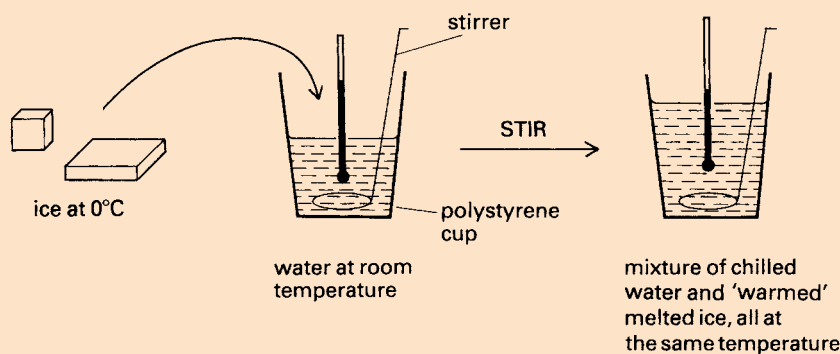

Figure 8.35 How much energy is needed to change the ice into water?

Finding the specific latent heat of fusion ice

Sample data:

Mass of cup empty = 23 g

Mass of cup + 'room temperature' water = 123 g

Initial temperature of 'room temperature' water = 17°C

Final temperature of chilled water + 'molten ice' = 5°C

Total mass of cup, water + 'molten ice' at end = 139 g

Your calculations:

1. How many grams of 'room temperature' water were there at the start?
2. By how many degrees was this water eventually chilled?
3. How much energy must have been removed from this water? Take the specific heat capacity of water to be $4.2 \text{ J g}^{-1} \text{ K}^{-1}$.
4. How many grams of ice at 0°C must there have been originally?
5. When, having melted, it warmed up from 0°C to the final temperature of the chilled mixture, how many joules of energy did it gain?
6. By comparing your answers to questions 3 and 5, how many joules of energy must the ice have taken in melting?
7. How much energy therefore was required to change 1 g of ice at 0°C into 1 g of water at 0°C?
8. Give your value for the specific latent heat of fusion of ice in both J/g and J/kg.

Specific latent heat of vaporisation

The specific latent heat of vaporisation (L_v) of water is about 2 300 000 J/kg. In other words, if you are trying to turn 1 kg of water into steam, even when its temperature has reached 100°C, you still have a long way to go: another 2.3 million joules of energy have yet to be supplied just to separate the molecules and so change the liquid to a gas.

The specific latent heat of vaporisation of a liquid is the thermal energy required to change 1 kg of the liquid at the boiling point into 1 kg of gas at the same temperature.

Again, to vaporise m kg the energy required is given by:

$$E_H = mL_v$$

Activity 8.26: Measuring the specific latent heat of vaporisation of water

In this activity you are trying to answer the following question: if we take 1 kg (or 1 g) of water which is already at 100°C , how many joules of heat energy must we supply to change it all into steam at 100°C ? The answer will be expressed in J/kg (or J/g). In principle the method is straightforward. You must take some water at its boiling point, and find out how much energy has to be supplied so that 1 kg (or 1 g) shall be boiled away. In practice, how can this be done?

A method using a Bunsen burner is depicted in Figure 8.36.

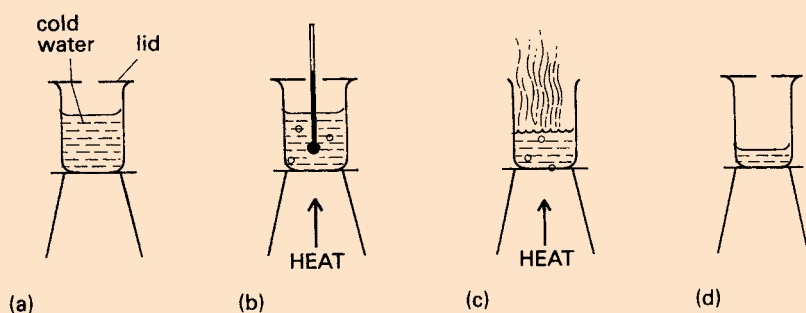

Figure 8.36 a) The mass of the cold water is known. b) The water is brought to the boil, using a Bunsen burner whose flame is not altered. Readings of temperature and time are taken. c) Still keeping the flame constant, the water is boiled for 10 minutes. d) The lid is replaced and the apparatus weighted to find out how much water has been boiled away.

Set up the apparatus as shown. The thermometer is there to measure how quickly the Bunsen burner heats the water. This enables you to work out how many joules of heat energy the Bunsen burner is supplying every second, so the flame must not be altered throughout the experiment.

Take readings and work out how much energy is needed to turn 1 g of water to steam.

Heat, temperature, internal energy and work

It is important that you are clear about the difference between heat and temperature. An example will show you that there is a difference. Suppose you have a race with a friend to see who can raise the temperature of some water from room temperature to 100°C the faster. To be fair, you each have an identical electric heater. There is just one point to mention, however: to be unselfish you give your friend a whole bucketful of water to warm up, and keep only a little in a cup for yourself.

You know the result, of course. Both of you are doing the same thing: raising the temperature of some water by about 80 K. To do this you need to do work (feed in energy). One person has far

KEY WORDS

internal energy *energy possessed by the molecules of a substance*

conduction *the transfer of heat energy through a material from molecule to molecule without any movement of the material itself*

insulation *use of a material that does not conduct heat energy and hence can prevent heat gain or loss*

more water than the other though, and she will have to feed in far more heat energy to do the job. Her heater must be switched on for a longer time, and her bill from the electricity company for energy supplied will be more.

Heat is a form of energy, measured in joules. When the water was heated and warmed up, the molecules of water moved faster. Thus the energy is stored in the hot water in the form of kinetic energy, the energy of motion of its molecules.

This energy is the **internal energy** of the water.

The word 'heat' is often used misleadingly in daily life. For example, some thermometers have 37°C marked as 'body heat'; what they should say is body temperature. When the weather is hot, this means that the temperature of the air outside is high.

Temperature, you may recall, may be described as the degree of hotness of a body, although that is rather a vague description. It is that which a thermometer records. A difference in temperature between two places can lead to a flow of heat energy between them, from the high temperature place to the lower temperature place. Thus the hot body will cool down and the cold one will warm up, the exchange of energy stopping when they have both reached the same temperature.

Heat transfer: conduction

If a bowl of hot soup is left standing on a table, it will get cold. Evaporation must be one cause of this, but it is not the only one. The table under the bowl becomes warm, and this is because heat has been conducted through the bowl.

Conduction is the passage of heat through a material from molecule to molecule, without any movement of the material as a whole.

If a spoon is left in a cup of coffee, the handle gets warm. A hot drink served in a metal mug is good for warming your hands, though the drink is not going to stay hot for long. These are examples of the **conduction** of heat through a metal.

Gases are even poorer conductors of heat than liquids. Air is thus a very good insulator, and commercial insulating materials are effective because they have many tiny pockets of still air trapped in them. An example is expanded polystyrene, used in coolers to keep your food and drink chilled. A refrigerator is lined between its inner and outer surfaces with a kind of woolly mat made from glass fibres loosely packed together.

Sometimes the purpose of the **insulation** is to keep things hot, rather than to protect cool things from the heat of the day. An oven needs to have lining similar to that in a refrigerator. Hot water pipes and steam pipes should be covered with a jacket made of expanded polystyrene or something similar to prevent a wasteful loss of heat.

Activity 8.27: Conduction in copper

Copper is a particularly good conductor of heat, and Figure 8.37 shows a demonstration of this.

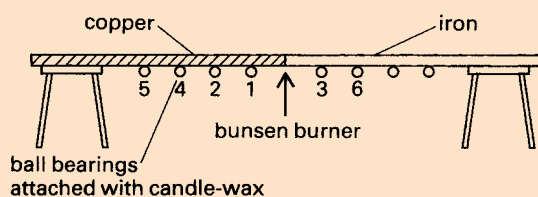

Figure 8.37 How to show that copper is a better conductor of heat than iron

Take a long bar made of copper at one end and iron at the other, joined together with a rivet. At regular intervals along it attach ball bearings with candle wax. Heat the bar strongly at its midpoint with a Bunsen burner. Record your observations. Try to explain them before reading on.

As heat is conducted along the bar in both directions, the wax melts and the ball bearings drop off. The iron conducts the heat, but not as well as the copper: the numbers on Figure 8.37 indicate a likely order in which the balls will fall.

Activity 8.28: Heat transfer in insulators

Metals generally are good conductors of heat, but most other substances are far poorer conductors (or, to look at it another way, are far better insulators).

A small electric heater used to warm a beaker of water can demonstrate this vividly. Use a low-value electrical resistor (perhaps 5 or 6 ohms if run off a 12-volt supply) as the heater, and arrange it so it is well clear of the bottom of the beaker (see Figure 8.38).

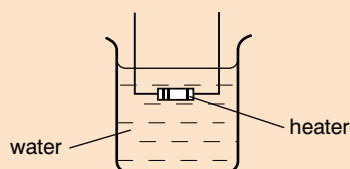

Figure 8.38 Showing that water is a poor conductor of heat

Do not switch on until the resistor is in the water or it will almost instantly burn out. Once in place, turn it on and leave it until the water has heated up.

Now feel the outside of the beaker high up, just below the water line. It will be hot, maybe uncomfortably so. Run a finger down the beaker, and you will find that there is a sudden change in temperature as you go below the heater. From that level downwards the water seems cold. Hot water is sitting on the top of cold water, yet hardly any conduction takes place.

Heat transfer: convection

If water is such a poor conductor, how is it that a kettle manages to heat its water up to boiling point? Why in Activity 8.28 was it only the water below the heater which was still cold?

The answer lies in thermal expansion. When water is heated it expands. This means that, comparing the same volumes, hot water is lighter than cold water. In other words, it is less dense.

In liquids and gases less dense substances are forced upwards. Oil floats on the top of water, for example, and hydrogen balloons rise when released in air. Therefore if some water is heated it expands, becomes less dense and so rises up to the surface. So long as the heating is being done at the bottom, this means that the water has a kind of inbuilt self-stirring mechanism. This is known as convection.

Activity 8.29: Observing convection

Convection can be observed in Figure 8.39 by taking a larger beaker of water and dropping in just one small crystal of potassium permanganate (a chemical that dissolves in water to give an amazingly deep purple colouring).

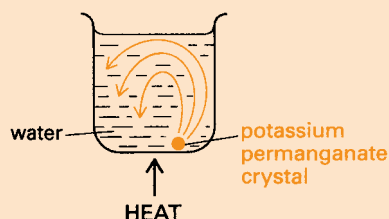

Figure 8.39 Convection currents in water

Heat the beaker gently under the crystal and watch how the coloured water rises to the surface in quite a fast and narrow stream. Cold water sinks in a wider and gentler draught to take its place.

The water in direct contact with the hot base gets heated by conduction. This water then rises, cold water replaces it and becomes warmed in its turn. These circulating currents are known as convection currents.

Convection is the transfer of heat throughout a fluid (that is, a liquid or a gas) by means of bulk movement of the hot fluid.

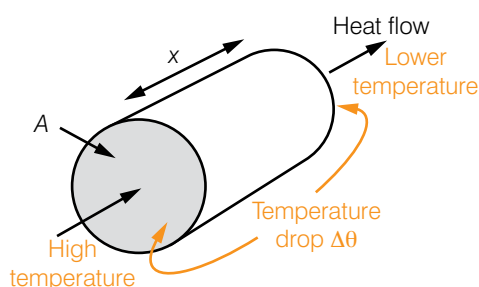

Figure 8.40 Thermal conductivity

Thermal conductivity

The rate at which heat energy will be conducted through a lagged bar is found to depend on three things:

- The material from which the bar is made.
- The area A of cross-section of the bar. Double the area, and heat is conducted through the bar at twice the rate.
- The temperature gradient along the bar – that is, how rapidly the temperature drops as you go along it. For a given conductor this takes into account both the temperature drop between its two ends and its total length. Using the notation in Figure 8.40, the temperature gradient will be $\Delta\theta / x$ (in K m^{-1}).

This means that the rate of flow of heat energy $\frac{Q}{t}$ in watts (J/s) along the bar will be given by:

$$\frac{Q}{t} = k A \frac{\Delta\theta}{x}$$

The constant k depends on which material the bar is made from. It is known as the material's **thermal conductivity**. The units of k work out to be W/m/K. Be sure you understand why.

KEY WORDS

thermal conductivity a measurement of the ability of a material to conduct heat

Worked example 8.14

The thermal conductivity of copper is 390 W/m/K. Calculate the rate of heat flow through a copper bar whose area is 4.0 cm² and whose length is 0.50 m, if a there is a temperature difference of 30°C maintained between its ends.

Start by putting down what you know. Here:

K (W/m/K)	A (m ²)	$\Delta\theta$ (K)	x (m)	Q/t (W)
390	4.0×10^{-4}	30	0.5	?

$$\frac{Q}{t} = k A \frac{\Delta\theta}{x} = \frac{390 \times 4.0 \times 10^{-4} \times 30}{0.5} = 2.3 \text{ W}$$

Worked example 8.15

Figure 8.41 Thermal conductivity of copper

Suppose you had to work out the rate of flow of heat through a bar made of two materials in contact, as shown in the drawing. Let the thermal conductivity of B be 400 W/m/K while that for C is 50 W/m/K.

Start by finding the temperature at the interface, θ say. This rate must be the same through B and through C.

$$\text{Equating them, } \frac{400 \times A \times (100 - \theta)}{2.0} = \frac{50 \times A \times (\theta - 30)}{1.2}$$

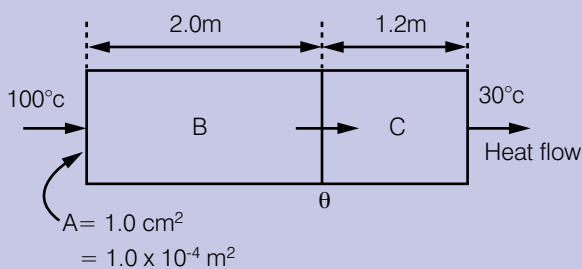
The A s cancel, and solving we get $\theta = 88^\circ\text{C}$.

You can then go back and substitute $\theta = 88^\circ\text{C}$ into the flow equation for either bar.

Thus, considering bar B,

$$\text{rate of flow of heat} = \frac{400 \times 1.0 \times 10^{-4} \times (100 - 88)}{2.0} = 0.24 \text{ W}$$

If you had chosen to substitute $\theta = 88^\circ\text{C}$ for bar C instead, check that the result would have been the same.

KEY WORDS

black body *a theoretical object that absorbs all electromagnetic radiation that hits it*

Stefan–Boltzmann law

If you have the opportunity, look at the bare element of an electric heater or something else that is red hot. There are likely to be some spots on the surface which are glowing more brightly than others. If so, remember where they are.

Let the body cool down and look again. You should find that the spots which glowed brightest are now the darkest parts of the surface – good emitters are good absorbers.

If we want to make a surface which will radiate freely to emit the maximum possible radiation at any given temperature, it will be a perfect absorber too. It will look matt black because no light will reflect from it: all is absorbed. We call this a **black body**.

The radiation a black body gives off depends on its temperature, and on nothing else. Figure 8.42 shows what will be emitted at a range of temperatures from 3500 K rising to 5500 K.

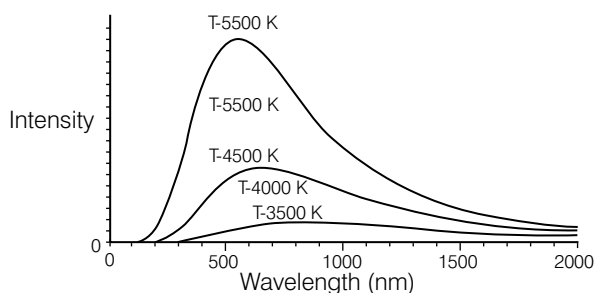

Figure 8.42 Black body radiation curve.

In Grade 10, you learnt that the wavelength of visible light ranges from about 750 nm (nanometres, $\times 10^{-9}$ m) at the red end of the spectrum down to 400 nm for the blue.

At 3500 K most of the radiation is in the infrared region, but just a little is visible light (mainly red). The surface is glowing red hot.

As it heats up further, two things happen: a greater amount of radiation is emitted in total, and the peak wavelength becomes smaller, so by 5500 K it is white hot. A pyrometer to measure temperatures might use either of those changes to estimate the temperature of the emitting surface.

The Stefan–Boltzmann law describes the total energy radiated by a black body. Consider a surface of area A at a temperature T (which must be its absolute temperature in kelvin). The radiated power P in watts (J/s) is given by:

$$P = \sigma A T^4$$

The constant σ (the Greek letter sigma) is a universal constant that does not depend on the material of the surface. All that is necessary is that it is behaving as a black body and so is radiating freely. Its value has been measured to be $5.67 \times 10^{-8} \text{ W/m}^2/\text{K}^4$.

Thus all surfaces above absolute zero emit radiation, though at low temperatures this is very feeble and none is in the visible range. Because it depends on T^4 , however, at very high temperatures radiation becomes a major source of energy loss. If the absolute temperature doubles, the radiated power increases sixteen fold; at ten times the temperature the power increases by a factor of 10^4 – 10 000 times!

Newton's law of cooling

If some hot water is contained in a beaker, the presence of a lid should reduce the rate of cooling. This stops continual evaporation from the water's surface. To change from a liquid to a vapour needs energy (which you know is called latent heat), and this is obtained from the water that remains. Evaporation causes cooling.

The cooling may be reduced further by lagging the beaker. What this means is that we put an insulating jacket round it to reduce the rate at which heat is being conducted to the outside world.

The rate of cooling of a hot body was one of the many topics which Newton investigated. His experimental result is known as **Newton's law of cooling**. It states that:

The rate of loss of heat from a body is proportional to its excess temperature above its surroundings.

Mathematically, this is written as $\frac{dH}{dt} = K \times A \times (\theta_{\text{sum}} - \theta_{\text{obj}})$

H is heat energy

t is time

K is heat transfer coefficient (a constant)

A is surface area of heat being transferred

θ_{sum} is temperature of surroundings

θ_{obj} is temperature of body

If the body is 20 K warmer than the room, it will lose heat twice as fast as if it was only 10 K above its surroundings. It is approximately true for a body in air for excess temperatures up to a few tens of kelvin. The actual rate of that loss of heat may be increased if we subject the body to what we call forced convection – such as blowing cold air from a fan over it.

Global warming and the greenhouse effect

The greenhouse effect was first proposed in 1824. It is the process by which absorption and emission of infrared radiation by gases in the atmosphere cause a rise in temperature of the Earth's lower atmosphere and surface. The increase in the average temperature of the Earth's near-surface air and oceans since the mid-20th century is called global warming.

KEY WORDS

Newton's law of cooling
the rate of change of the temperature of an object is proportional to the difference between its own temperature and the temperature of its surroundings

Activity 8.30: Investigating cooling

Plan and, if you can, carry out an investigation into one of these topics:

1. How much difference does the lid make to how quickly a beaker of hot water cools?
2. Compare the effectiveness of different materials in providing insulation.

In either case, ask yourself what will have to be kept the same every time and what should be varied. What measurements will you take, and how? How will you analyse those readings to get as much information as possible from them? How will you present your conclusions so other people may follow them clearly?

Activity 8.31: Research global warming

In a small group, research global warming. Present your research in a format of your choice.

Summary

In this section you have learnt that:

- Calorimetry is the science of measuring the heat of chemical reactions or physical changes.
- A phase is a state of matter, e.g. solid, liquid, gas.
- A phase change occurs when a substance changes state.
- A phase diagram shows the three phases of a substance.
- State variables are properties such as temperature, pressure and internal energy.
- The critical point is where the liquid and gas phases become indistinguishable.
- The triple point is where all three states coexist together.
- Latent heat is energy that is supplied to a substance but does not result in a rise in temperature but does result in a change of phase (measured in J/kg).
- Specific heat capacity is the number of joules of heat energy required to raise the temperature of 1 kg of a substance by 1 K (measured J/kg/K).
- Heat capacity = mass specific \times heat capacity (measured J/K)
- Heat is a form of energy (measured in J).
- Temperature is the quantity a thermometer records
- Internal energy is the energy possessed by the molecules of a substance.
- The rate at which heat energy will be conducted through a lagged bar of length x depends on: the material the bar is made from, the area of cross-section, A , of the bar, the temperature gradient along the bar, $\frac{\Delta\theta}{x}$

Review questions

1. Define the terms a) calorimetry, b) phase, c) phase change, d) phase diagram, e) state variable, f) latent heat, g) heat capacity, h) specific heat capacity.
2. Distinguish between heat, temperature, internal energy and work.
3. Give the units for heat, heat capacity, specific heat capacity and latent heat.
4. Explain the factors that determine the rate of heat flow through a material.
5. Work out the rate of flow of heat through the bar shown in Figure 8.43. Let the thermal conductivity of B be 450 W/m/K while that for C is 150 W/m/K.
6. Describe experiments to measure latent heat.

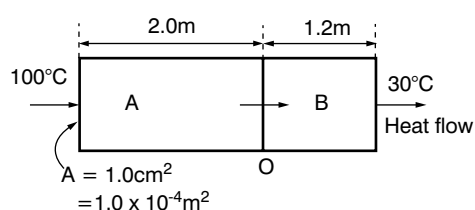

Figure 8.43

End of unit questions

- Construct a glossary of all the key terms in this unit. You could add it to the one you made for Units 1–7.
- State Hooke's law.
- A 0.50 kg mass is hung from the end of a wire 1.5 m long of diameter 0.30 mm. If Young's modulus for its material is 1.0×10^{11} Pa,
 - calculate the extension produced
 - hence find the strain energy.
- Describe the concepts related to hydraulic and pneumatic systems.
- Find the height of a column of methyl iodide in a soda-lime glass tube of radius 20 mm. The surface tension is 0.26, the contact angle is 29° , the density is 2.28.
- Identify factors affecting laminar flow.
- Explain applications of Bernoulli's principle.
- A healthy section of artery of length 10 cm and radius r has a pressure difference of 120 mmHg. The volume flow rate of the blood in the artery is 100 cm^3 the viscosity of blood is η . A diseased artery of the same length has a radius which is half that of the healthy artery. The volume flow rate of the blood in this artery is $6.3 \text{ cm}^3/\text{min}$. What pressure difference is needed to bring the volume flow rate up to $100 \text{ cm}^3/\text{min}$? (Assume the viscosity of the blood is the same as the healthy artery.)
- Find the force on a ball bearing of radius 5×10^{-3} m falling through a liquid of viscosity 0.985 at a velocity of 0.35 m/s.
- Water flows at $20 \text{ m}^3/\text{h}$ through a pipe with 150 mm inside diameter. The pipe is reduced to an inside dimension of 120 mm. Find the velocity of the water in each part of the pipe.
- Draw a phase diagram for water
 - Explain what is meant by i) critical point, ii) triple point.
- The diagram shows two slabs of material in contact. A is 2.0 cm thick and its thermal conductivity is 3.0 W/m/K . B is 4.0 cm thick and of conductivity 1.5 W/m/K . The left hand face of A is kept at 0°C and the right hand face of B at 100°C .
 - The slabs have been in place long enough for the temperatures within them to become steady. Which of the following quantities will have the same value in A and in B:
 - temperature gradient
 - temperature difference between opposite faces
 - rate of flow of heat?
 - Find the temperature at the junction of A and B.
 - What is the rate of flow of heat through the slabs?
- Describe an experiment to demonstrate conduction in copper.

Index

- absolute pressure 166
- absolute velocity 61
- acceleration 42
 - angular 123
 - constant 43–46
 - due to gravity 44–46
 - from velocity-time graph 42, 47–49
 - uniform circular motion 55–56
- accepted values 9
- accuracy 13, 14
- air resistance 44–45, 115, 177
- aircraft
 - airspeed measurement 180
 - lift forces 175, 180
 - turbulence 176
- altitude 169
- analysis 4, 20
- angles, measuring 55
- angular acceleration 123
- angular impulse 136–137
- angular momentum 76, 135
 - law of conservation of 138–139
- angular velocity 55–56, 119
- Archimedes's principle 169–170
- atmospheric pressure 166
- average acceleration 42
- average velocity 41–42
- axis of rotation 119
 - parallel axis theorem 133–134
 - rotational inertia and 125, 133–134

- banked roads 93–94
- Bernoulli's principle 175, 179–180
- black bodies 196–197
- boiling 188, 189, 190–191
- brittle materials 162
- bulk modulus 164
- buoyant forces 169–170

- calculated values 7–8, 15–16
- calorimetry 187
- capillary action 173–174
- carburettors 180
- cars
 - safety features 80
 - streamlining 177
 - uniform circular motion 92, 93–94
- centre of mass 86–88
 - equilibrium and 152
 - of particle systems 140–141
 - of rigid bodies 140–142
- centripetal force 57–58, 95
- changes of state 187, 188
- co-ordinate grids 40, 41
- coefficient of viscosity 181
- collinear vectors 24, 28–30
- collisions 82–84, 113
- commutative law 28
- component vectors 26, 31, 41
- compressibility, effect on fluid flow 176
- compressional deformation 159
- conclusions 4, 20
- concurrent forces 144–145
- conduction 192, 193
- conservation of angular momentum, law of 138–139
- conservation of energy, law of 111–113, 115
- conservation of linear momentum, law of 76–77, 79
 - in collisions 82–84, 113
 - variable mass systems 90–91
- conservative forces 114, 115
- contact angle 172
- convection 194, 197
- conversion factors 15
- cooling, Newton's law of 197
- coplanar forces 146, 151–153
- coplanar vectors 25, 28–30
- couples 155–156
- critical point 187
- crumple zones 80

- deformation 159–161
 - elastic limit 161
 - modulus of elasticity 162–164
- density
 - of the atmosphere 169
 - effect on fluid flow 176
 - pressure and 166
- displacement, from velocity-time graph 47–49
- displacement-time graphs 41, 44, 46–47
- dissipative forces 114, 115
- dot product *see* scalar product
- ductile materials 162
- dynamic equilibrium 151

- dynamic pressure 179, 180
- dynamics, basic laws of 69–73

- elastic behaviour 159–165
- elastic collisions 82, 113
- elastic deformation 159, 161
- elastic limit 159–160, 161
- elastic potential energy 107
- energy 103
 - conservation of 111–113, 115
 - heat *see* heat energy
 - kinetic *see* kinetic energy
 - mechanical 111, 114–115
 - in oscillations 112
 - potential 103–104, 107–109
 - stored in a spring 108–109
 - strain energy 164–165
 - surface energy 171
- equation of continuity 177–178
- equations of motion
 - linear motion 39, 129
 - rotational motion 129, 131
- equilibrium
 - concurrent forces 144–145
 - conditions 151
 - coplanar forces 151–153
 - floating objects 169
 - limiting 72
 - of a particle 144–145
 - rotational 154
- errors 9–12
 - parallax errors 10–11
 - random errors 9–10, 15
 - systematic errors 11–12
 - zero errors 12
- evaporation 189, 192, 197
- experiments 1, 3–4
 - writing up 17–18
- explosions 91

- falling bodies 44–46
- floating objects 169–170
- flow rate 176, 177–178
- fluids
 - Bernoulli's principle 175, 179–180
 - bodies moving in 181–182
 - equation of continuity 177–178
 - flow rate 176, 177–178
 - laminar flow 175, 182
 - measuring flow speed 180

- turbulent flow 175–176, 182
- viscosity of 180–181
- see also* liquids
- force-displacement graphs 102–103
- force-extension graphs 108–109, 161, 162
- forces 67
 - addition 31
 - centripetal 57–58, 95
 - change of momentum and 80
 - concurrent 144–145
 - conservative 114, 115
 - coplanar 146, 151–153
 - in deformation 159–160
 - dissipative 114, 115
 - effect on springs 108–109
 - equilibrium and 144–145
 - moments of 85–86, 146–149
 - resolving 67–68
 - in uniform circular motion 57–59, 92–95, 119
 - viscous drag 180–182
 - work done and 99–103
- frames of reference 40–41, 130
- framework for reports 18–20
- free body diagrams 44–45
- friction 71–73, 104
 - in circular motion 57, 92–94
 - as dissipative force 115
- fusion *see* melting

- Galileo Galilei 46, 73
- gases, collisions in 82
- glancing collisions 83
- global warming 197
- gravitational potential energy 107, 108, 114, 115
- gravity 60, 73
 - acceleration due to 44–46
 - as conservative force 115
 - motion in a vertical circle 57–59
 - work done against 99–100, 106, 107–108
- greenhouse effect 197
- gyroscopes 135, 136

- head-on collisions 83
- heat energy 191–192
 - changes of state and 188
 - radiation of 196–197
 - rate of loss 197
 - thermal conductivity 194–195
 - transfer of 192–194
- Hooke's law 161
- hydraulic brakes 167
- hypothesis 2, 3, 4

- impulse 78–80, 136
- inelastic collisions 82, 113
- instantaneous acceleration 42
- instantaneous velocity 41
- instruments
 - parallax errors 10–11
 - precision 5, 6, 15
 - zero errors 12
- insulation 192, 193, 197

- Kepler's laws 95
- kinetic energy 104
 - in collisions 83, 113
 - during changes of state 187
 - rotational 126–127
 - transfers to potential energy 111–112
 - work and 104–105
- kinetic friction 71, 72–73, 104

- laminar flow 175, 182
- latent heat 188
- limit of proportionality 161
- limiting equilibrium 72
- limiting friction 72
- linear momentum 76, 135
 - law of conservation of 76–77, 79, 82–84, 90–91, 113
 - rate of change of 80
 - variable mass systems 90–91
- liquids
 - capillary action 173–174
 - contact angles 172
 - pressure difference across surface 171
 - surface energy 171
 - surface tension 170–173
 - transmission of pressure in 167–168
 - viscosity 180–181
 - see also* fluids

- measurements 4–7
 - accuracy 13, 14
 - errors in 9–12
 - multiple values 7, 15
 - precision 5, 6, 13, 14
 - significance 13–14
 - significant figures 4–5, 13
 - uncertainties 6–7
 - units 4, 15
- mechanical energy 111, 114–115
- melting 188, 189–190
- meniscus 173
- mistakes 9
- moment of a force 85–86, 146–149
- see also* torque

- moment of inertia *see* rotational inertia
- mousetrap car 106
- multiple values 7, 15

- neutral buoyancy 170
- neutral equilibrium 152
- Newton's cradle 79
- Newton's law of cooling 197
- Newton's law of universal gravitation 60, 73
- Newton's laws of motion
 - demonstrating 70
 - first law 57, 69, 144
 - linear momentum 76
 - second law 70, 71, 76, 90, 104–105
 - third law 70, 76, 90

- orders of magnitude 16

- parallax errors 10–11
- parallel axis theorem 133–134
- parallelogram rule 29
- Pascal's law 167
- peer review 2
- pendulums 58, 112
- percentage uncertainties 7–8
- phase change diagrams 187
- phase changes 187, 188
- phases 187
- planetary motion, Kepler's laws of 95
- plastic deformation 159, 161
- pneumatics 168
- position vectors 24
- potential energy 103–104, 107–109
 - transfers to kinetic energy 111–112
- power 116, 132
- precision 13, 14
 - of instruments 5, 6, 15
 - uncertainty and 6, 13
- predictions 3
- pressure
 - due to a fluid column 166–167
 - dynamic 179, 180
 - static 179, 180
 - transmission in liquid 167–168
- projectile motion 52–54
- Pythagoras's theorem 27, 30

- racetracks 93–94
- radial force 57, 95, 119
- radians 55, 119
- radiation 196–197
- random errors 9–10, 15
- recoil-less rifles 79
- relative velocity 61

- report writing 17–20
- research 3
- results, recording 17–18
- Reynolds number 182
- right-hand rule 35, 121
- rockets 90
- rotation about a fixed axis 119
- rotational equilibrium 154
- rotational inertia 124–126
 - parallel axis theorem 133–134
- rotational kinetic energy 126–127
- rotational motion
 - equations 129, 131
 - frame of reference 130
- rotational stability 169

- sailing craft 180
- satellites, motion of 60
- scalar product 33–34
- scalar projection 34–35
- scalar quantities 23, 33
- scale diagrams 28
- scientific method 1, 2–4
- seat belts 80
- shear deformation 159
- shear modulus 164
- significance 13–14
- significant figures 4–5, 13
- specific heat capacity 184–187
- specific latent heat
 - of fusion 189–190
 - of vaporisation 190–191
- speed 41
- springs
 - conservative forces 115
 - energy stored in 108–109
- stability 87–88, 140
 - floating objects 169
 - rotational 169
- stable equilibrium 152
- static equilibrium 151
- static friction 71–72, 104
- static pressure 179, 180

- Stefan–Boltzman law 196–197
- Stokes’s law 181–182
- strain energy 164–165
- streamline flow 175, 182
- streamlining 177
- submarines 169–170
- surface energy 171
- surface tension 170–173
- systematic errors 11–12

- tangential force 95
- temperature 191–192
 - changes of state and 187
 - cooling and 197
 - effect on fluid flow 176
- tensile deformation 159, 160
- tensile strain 161
- tensile stress 160
- terminal velocity 46, 182
- thermal conductivity 194–195
- thermal energy *see* heat energy
- thermal expansion 194
- torque 85–86, 120–123, 136, 146, 147
 - of a couple 155–156
 - in rotational equilibrium 154
 - work done by 122, 132
- torsional deformation 159
- triangle rule 29–30
- triple point 187
- true values 9, 13
- turbulent flow 175–176, 182

- uncertainties 6–7, 13
 - calculating 7–8
 - from instruments 15
 - percentage uncertainties 7–8
- uniform circular motion 55–57
 - forces acting 57–59, 92–95, 119
 - in a horizontal circle 57, 92–94
 - in a vertical circle 57–59, 95
- unit vectors 24, 35, 121
- units 4, 15
- unstable equilibrium 152

- vaporisation *see* boiling; evaporation
- vector product 35–36, 121
- vectors 23
 - addition and subtraction 28–31
 - applications 36
 - multiplication 33–36
 - representing 23
 - resolving 26
 - scalar product 33–34
 - scalar projection 34–35
 - types 24–25
 - vector product 35–36, 121
- velocity 41–42
 - absolute 61
 - angular 55–56, 119
 - constant acceleration and 43–46
 - from displacement–time graph 41, 44, 46–47
 - motion in a vertical circle 57–59
 - relative 61
 - terminal 46, 182
- velocity–time graphs 42, 47–49
- viscosity 180–181
- viscous drag force 180–182

- weightlessness 74
- work 99, 101
 - against gravity 99–100, 106, 107–108
 - done by constant forces 99–102, 103
 - done by a torque 122, 132
 - done by variable forces 102–103
 - extension of a spring 108
 - kinetic energy and 104–105
- work–energy theorem 104–106

- yield point 161
- Young modulus 162–163
- Young–Laplace equation 171

- zero errors 12

